

# APPLICATION GUIDE

# NEUTRAL EARTHING RESISTORS or REACTORS

(including resonant reactance earthing)

NZCCPTS

Issue 3

September 2010

## **The New Zealand Committee for the Co-ordination of Power and Telecommunication Systems Inc. (NZCCPTS)**

The New Zealand Committee for the Co-ordination of Power and Telecommunication Systems was established in 1985 following the increasing need to implement efficient cost-effective measures for the limitation of hazard and interference to power and Telecommunications Systems and Personnel.

Such measures not only require the determination of optimum engineering solutions consistent with minimum national cost, but also necessitate clear guide-lines covering the equitable allocation of responsibilities during all work phases from planning through to in-service operation.

The objective of the New Zealand Committee for the Co-ordination of power and Telecommunication Systems is to meet these needs and, by means of publications and seminars, promote a greater awareness and understanding of the action that must be taken to ensure that Power and Telecommunication Systems coexist satisfactorily.

Membership of the Committee and its Working parties currently comprises representatives for each of the following organizations:

- ◆ Transpower New Zealand Ltd.
- ◆ Telecom New Zealand Ltd.
- ◆ Electricity Engineers' Association of New Zealand Inc.
- ◆ KiwiRail (NZ Railways Corporation)
- ◆ Energy Safety, Ministry of Economic Development

For further information concerning this Committee and its published guides, contact:

The Secretary  
NZCCPTS  
3 Moehau Grove  
Trentham  
Upper Hutt 5018  
NEW ZEALAND

**Secretary as at September 2010**

Michael O'Brien  
Consulting Engineer  
Ph: 0-4-528 9117  
Fax: 0-4-528 9116  
Email: [hazmic.ob@xtra.co.nz](mailto:hazmic.ob@xtra.co.nz)

**APPLICATION GUIDE  
FOR  
NEUTRAL EARTHING  
RESISTORS / REACTORS**

(including resonant reactance earthing)

for the control of earth fault currents in power systems  
operating at 33kV or less

**Published and issued by:**

**The New Zealand Committee for the Co-ordination of  
Power and Telecommunication Systems Inc. (NZCCPTS)  
3 Moehau Grove  
Trentham  
Upper Hutt 5018  
NEW ZEALAND**

**Issue 3**

**September 2010**

**ISBN 978-0-473-17117-9**

## Foreword

The guide sets out recommended practices which should be used for the planning, design and co-ordination of Power Systems, when it is desired to install Neutral Earthing Resistors/Reactors (NER's) (including resonant reactances) to limit the flow of current during a fault between phase and earth. The guide focuses on the use of NER's to control the level of Induction or Earth Potential Rise (EPR) hazard to telecommunication users, staff and plant. However, the principles apply to the installation of NER's for any purpose, and consideration is given to industrial usage.

## Acknowledgements

Section 5.3.1 is reprinted from IEC71-2 Insulation Co-ordination - Part 2 : Application Guide, Annex B with permission of Standards New Zealand. Copyright of this material remains the property of the International Electrotechnical Commission.

NZCCPTS is also indebted to the Electricity Engineers' Association of New Zealand, Telecom New Zealand Limited, Tranz Rail Limited, and the Energy Safety Service Group, Ministry of Consumer Affairs, for their contributions in the formation of this guide. NZCCPTS also records the kind permission of the authors for the papers included as appendices E, F, and G, together with the permission of the Electricity Engineers' Association of New Zealand. Appendices were initially published as EEA Conference papers.

**“The information contained in this booklet has been compiled by the NZCCPTS for the use of its members from sources believed to be reliable, but neither the NZCCPTS nor any of the contributors to this booklet (whether or not employed by NZCCPTS) undertake any responsibility for any mis-statement of information in the booklet, and readers should rely on their own judgement or, if in doubt, seek expert advice on the application of the guidelines to work being carried out.”**

Comments for revision of this guide are welcomed. Any comments or information that may be useful for inclusion in future issues should be forward to:

Michael O'Brien  
Secretary  
NZCCPTS  
3 Moehau Grove  
Trentham  
Upper Hutt 5018  
NEW ZEALAND

Ph: 0-4-528 9117  
Fax: 0-4-528 9116  
Email: [hazmic.ob@xtra.co.nz](mailto:hazmic.ob@xtra.co.nz)

A brief description of the objectives and organization of the New Zealand Committee for the Co-ordination of Power and Telecommunication Systems Inc. is printed inside the cover of this publication.

## Document History

<u>Issue No.</u>	<u>Publication Date</u>
1	November 1994
2	August 2002
3	September 2010

# Contents

<b>1</b>	<b>Introduction</b>	<b>1</b>
1.1	<i>Scope</i>	1
1.2	<i>Background</i>	1
1.2.1	Induction (Magnetic Coupling)	1
1.2.2	Capacitive (Electric Coupling)	1
1.2.3	Direct Contact	2
1.2.4	Earth Potential Rise (EPR)	2
1.3	<i>Hazard to Telecommunication Networks</i>	3
1.4	<i>Methods of Mitigating EPR and Induction Hazard to Telecommunication Networks</i>	3
1.4.1	Telecommunication System Isolation	3
1.4.2	Increase the Separation between the Power and Telecommunication Plant	3
1.4.3	Install Gaseous Arresters in Telecommunication Plant	3
1.4.4	Shielding of Telecommunication Conductors	4
1.4.5	Add Earth Return Conductor	4
1.4.6	Lower the Resistance of the Power Earthing System	4
1.4.7	Increase Zero Sequence Impedance using a Neutral Impedance	5
<b>2</b>	<b>Definition of Terms and Drawing Symbols</b>	<b>6</b>
<b>3</b>	<b>Devices and Methods of Earthing</b>	<b>8</b>
3.1	<i>Overseas and NZ Practice</i>	8
3.1.1	United Kingdom (UK) Practices	8
3.1.2	European Practices	9
3.1.3	Australian Practices	9
3.2	<i>Solid Earthing</i>	9
3.3	<i>Unearthed Systems</i>	10
3.4	<i>Resonant Earthing (Petersen Coils, Arc Suppression Coils, Earth Fault Neutraliser Earthing)</i>	10
3.5	<i>Resistive/Reactive Earthing</i>	10
3.5.1	Reduction of Earth Fault Current	11
3.6	<i>Use of Earthing Transformers</i>	11
<b>4</b>	<b>Current Considerations</b>	<b>11</b>
4.1	<i>Source Fault Levels</i>	11
4.2	<i>Earth Fault Current Path</i>	11
4.3	<i>Effect of an NER on EPR</i>	13
4.4	<i>Effect of an NER on Magnetically Induced Voltages</i>	13
<b>5</b>	<b>Voltage Considerations</b>	<b>15</b>
5.1	<i>Introduction</i>	15
5.1.1	Lightning	15
5.1.2	Switching Surges	15
5.1.3	Electrostatic	15
5.1.4	Contact with Higher Voltage System	15

5.1.5	Line-to-Earth Faults	16
5.1.6	Resonant Conditions	16
5.1.7	Re-striking Earth Faults	16
5.2	<i>The Effect of Earthing Methods on System Voltages</i>	16
5.2.1	Earthing the System Neutral	16
5.2.2	Effectively Earthed System	16
5.2.3	Reactance-Earthed System	17
5.2.4	Resonant-Earthed System	17
5.2.5	Resistance-Earthed System	17
5.2.6	Unearthed System	18
5.3	<i>Transient Effects</i>	18
5.4	<i>Application in New Zealand</i>	23
6.1	<i>Introduction</i>	24
6.2	<i>Changes to Network Protection</i>	24
6.3	<i>Protection of the NER and associated Transformer</i>	26
6.3.1	NER	26
6.3.2	Transformer Protection	26
<b>7</b>	<b>Design Criteria and Device Selection</b>	<b>28</b>
7.1	<i>Introduction</i>	28
7.2	<i>Existing System Components</i>	28
7.2.1	General	28
7.2.2	Transformers	28
7.2.3	Switchgear	30
7.2.4	Cables	31
7.3	<i>Impedance Value</i>	31
7.4	<i>Impedance Type</i>	31
7.4.1	Resistors	31
7.4.2	Reactors	32
7.5	<i>Design for Reliability</i>	33
7.6	<i>Comparative Costs</i>	33
<b>8</b>	<b>Electrical Connections for NERs</b>	<b>37</b>
<b>9</b>	<b>Installation</b>	<b>44</b>
9.1	<i>Retrofit of an NER</i>	44
9.2	<i>New Installations incorporating NER's</i>	44
<b>10</b>	<b>Commissioning</b>	<b>45</b>
<b>11</b>	<b>Routine Maintenance</b>	<b>45</b>
<b>12</b>	<b>General AC Network Benefits of Installing NER's</b>	<b>45</b>
<b>13</b>	<b>The use of NERs in Mining and Industrial Applications</b>	<b>46</b>
13.1	<i>General Mining Applications</i>	46
13.2	<i>Underground Mining Sites</i>	47
13.3	<i>NER's in other Industries</i>	47
<b>14</b>	<b>References</b>	<b>48</b>

<b>Appendix A</b>	<b>Time Domain Study of EPR</b>	<b>49</b>
<b>Appendix B</b>	<b>Investigations into EPR Transient Phenomena</b>	<b>52</b>
<b>Appendix C</b>	<b>Typical Maintenance Schedule for a Liquid Earthing Resistor</b>	<b>53</b>
<b>Appendix D</b>	<b>Indicative Costs for the Installation of Stainless Steel Resistor NER's</b>	<b>56</b>
<b>Appendix E</b>	<b>Results of a 10 Year Study of Earth Faults on a Combined Urban/Rural 33/11 kV Substation Equipped with NER</b>	<b>59</b>
<b>Appendix F</b>	<b>The first application of resonant earthing with residual compensation to a New Zealand distribution network</b>	<b>65</b>
<b>Appendix G</b>	<b>Resonant Earthing - Advantages and Disadvantages. Why Do We Not Use It in New Zealand?</b>	<b>84</b>

# 1 Introduction

## 1.1 Scope

### ***This guide describes***

the issues which should be considered when it is desired to install neutral earthing resistors or reactors (NER's) (including resonant reactances) on power systems having a phase to earth voltage less than 20.5kV to limit the magnitude of phase to earth fault currents, for the purpose of controlling the EPR and induced voltages on nearby telecommunication systems to below hazard levels.

Nothing in this Guide shall relieve all those who own and operate electric power lines from complying with the provisions of the Electricity Regulations or any other statutory Act or Regulation.

The guide does not describe all the conditions to be met for systems operating at higher phase to earth voltages than 20.5kV, because such systems may incorporate plant with graded insulation or may be designed for less than the basic insulation levels (BIL) needed when using an NER.

The effect of insulation ageing and consequent reduction of basic insulation level has not been taken into account in this guide.

## 1.2 Background

There have been many instances of telecommunication system damage due to excessive impressed current and voltage from the nearby power system (usually during earth faults on the power system). These present a hazard to telecommunication system users and staff, as well as telecommunication system plant.

The mechanisms through which this hazard or damage arises are:

- Induction (Magnetic Coupling)
- Capacitive (Electric Coupling)
- Direct Contact
- Earth Potential Rise

### **1.2.1 Induction (Magnetic Coupling)**

When an earth fault occurs in a power supply system, the net unbalanced fault current that flows in the power line (and returns via earth) creates a magnetic field. If a telecommunication cable runs parallel to the power line for a sufficient length, a high voltage may be induced by this magnetic field onto any metallic conductors in the telecommunication cable.

### **1.2.2 Capacitive (Electric Coupling)**

When a power system earth fault occurs, a significant unbalanced voltage to ground (zero-sequence) will be developed on the power system conductors. A small unbalanced voltage can also occur under steady state conditions as a result of unbalanced phase impedances, or unbalanced 3 phase loading. The unbalanced voltage (AC or DC) sets up an electric field between the conductors of the power system and the ground beneath. Aerial metallic telecommunication circuits and plant situated in this electric field can have voltages "capacitively coupled" onto them.

A live, i.e. a charged conductor has an associated electric field. Any unearthed conductor within such an electric field (or a conductor connected to earth via a high impedance) will be charged by the electric field to a voltage determined by the capacitance between the source conductor and the secondary conductor, and the capacitance between the secondary conductor and ground.

Such capacitive coupling is independent of exposure length, but the source impedance behind the capacitively established voltage (i.e. the ability to deliver



a hazardous current) is dependant on exposure length. Length determines the total capacitance of the affected conductor and hence the total charge which can be stored on it.

**Note:** The source impedance is inversely proportional to the capacitance between the two lines.

As the impedance (capacitance) to ground of the affected conductor also affects the energy which can be stored on that conductor, problems caused by capacitive coupling can be resolved by burying the power and/or communications line, thereby eliminating the capacitive relationship. It should be noted that burying lines will have no benefit in the case of magnetic coupling.

### 1.2.3 Direct Contact

This refers to contact between the telecommunication and power conductors, e.g., falling lines. Direct contact is not within the scope of this Guide.

### 1.2.4 Earth Potential Rise (EPR)

When earth fault currents flow via the fault through the mass of earth back to the current source, usually a transformer star point, the earth potential at the fault location (and at the source transformer earthed star point) rises with respect to remote earth as a result of current passing through the resistance of the earth.

*A detailed description of EPR is given in the NZCCPTS Application Guide for Earth Potential Rise.*

When a telecommunication cable traverses an earth potential rise hazard zone, hazardous (EPR) voltage may be coupled directly onto conductors in the telecommunication cable if either;

- a telecommunication conductor is earthed inside the hazard zone  
or
- the EPR of the ground surrounding the telecommunication cable exceeds the cable's insulation rating.

Some power systems, even when earthed in accordance with the Electricity Regulations, can still cause EPR's of several thousand volts. These systems are often in close proximity to telecommunication plant or their EPR is effectively brought into close proximity via the Multiple Earthed Neutral (MEN) system.

Consequently EPR on power system earths can be a serious hazard to telecommunication system users, staff and plant.

EPR caused by a power line "contacting" the ground (e.g. by falling, or by insulation failure between the line and the ground ) in an area not associated with a power system earth, is unlikely to cause a voltage hazard to telecommunication system users, staff or plant for the following general reasons:

- Such contacts are unlikely to occur in close proximity to telecommunication plant.
- The resultant EPR usually falls off very rapidly to a safe level within a few metres of the contact point.

It is therefore not felt necessary to protect telecommunication system plant from such incidents.

The effect of EPR in the vicinity of telecommunication system plant can be very serious. Telecommunications users or staff may be subject to a significant

proportion of the EPR voltage, and the resultant fault current flow in the telecommunication network can cause very considerable damage to telecommunication plant which is costly to repair.

Damage is often not localised and this often makes repairs difficult and expensive. The telecommunication service to large areas can be lost for the duration of the fault repair.

### **1.3 Hazard to Telecommunication Networks**

Capacitive coupling rarely causes any problems, mainly because of the small currents involved. The risk of direct contact is addressed via industry use of standard minimum separations, practices and materials.

The hazard mechanisms of by far the greatest concern to telecommunication networks are induction (by magnetic coupling) and EPR. Both are the result of earth faults on power systems.

In some cases, a telecommunication cable may be affected by both EPR and induction, caused by the same earth fault. The total effect of this is normally calculated by adding the EPR and induced voltages in quadrature (i.e. adding the two vector voltages, with the two vectors at 90° to one another), unless their true phase relationship is known.

NER's can substantially reduce the magnitude of any earth fault currents, and hence also greatly mitigate any EPR and/or induction problems.

### **1.4 Methods of Mitigating EPR and Induction Hazard to Telecommunication Networks**

#### **1.4.1 Telecommunication System Isolation**

At risk telecommunication users within an EPR hazard zone can be protected by using isolation.

This can be achieved by

Using isolating transformers at approximately \$1,000 each (1999). One device per customer is required.

- Use of a fibre optic system.

If a large number of telecommunication customers is involved, or a fibre optic cable solution is adopted, these options can prove very expensive.

Also, a monitoring system will need to be put into place to ensure that if in the future any new customers arrive in the area, or any extra lines are requested by existing customers, that these lines also have appropriate isolation fitted. As with all such systems, there remains a significant risk that at some time in the future this could be overlooked, and the new customer(s) put at risk.

Isolation may be the cheapest solution in the short term, but end up being the most expensive in the long term. A cheap short-term solution can be regarded as a "band-aid" solution, treating the "symptoms" rather than the "cause".

#### **1.4.2 Increase the Separation between the Power and Telecommunication Plant**

This is not usually practical/possible because in most situations the services have common alignments/locations, or are already in place.

#### **1.4.3 Install Gaseous Arresters in Telecommunication Plant**

Gaseous arresters are only effective in protecting against induction (magnetic coupling). Each pair in a telecommunication cable subject to hazardous induction, have three terminal gaseous arresters connected to the two legs of the pair and to a local earthing system, generally at a number of points along

its length. If the voltage (to earth), induced along the telecommunication cable pairs between successive gaseous arrester installations, exceeds the arrester ignition value, the arresters fire, clamping the leg-leg and leg-earth voltages.

However, in order to ensure these voltages are limited to acceptable levels, earthing systems with very low earth resistances are needed. While the gaseous arresters are relatively cheap, in rural NZ areas (where most of the induction hazard problems occur), obtaining very low earth resistances is usually either very expensive, or impractical. Consequently this form of mitigation is rarely used.

Care must be taken to ensure no gaseous arrester mitigation is installed in, or near, an EPR hazard zone. Otherwise there is a danger of the gaseous arresters “backfiring”, and coupling the local EPR voltage directly onto the telecommunication cable conductors.

#### **1.4.4 Shielding of Telecommunication Conductors**

Shielding will not provide any protection against EPR although it is of benefit in reducing magnetic and electric coupling.

#### **1.4.5 Add Earth Return Conductor**

If a continuous metallic earth return conductor is provided all the way back to the source transformer via the sheath of the power cable or via a separate earth wire (either buried or attached to the pole line), the likelihood of fault currents damaging Telecom plant will be greatly reduced. This assumes the use of traditional cables with substantial sheaths which are appropriately bonded. However, both of these solutions may be impractical for retrospective application.

There may be individual situations where an overhead or underground earth wire (connecting back to the feeder transformer neutral) can provide a quick, economical and practical solution.

The impact of cable sheath bonding is covered in detail in the NZCCPTS Application Guide for Cable Sheath Bonding.

#### **1.4.6 Lower the Resistance of the Power Earthing System**

The earth resistance of a power system earth mat can be reduced by two means:

1. expanding the local earthing system, or
2. bonding other “remote” earthing systems to it.

If the local power system earth mat is expanded, its earth resistance will be reduced, and the EPR on that earth mat will decrease. The corresponding step and touch voltages in the vicinity of the earth mat will likewise decrease.

However, any induction hazard to telecommunication networks, and any EPR levels at the location of nearby telecommunication plant (that is not located within the earth mat), will increase. This is because:

1. Any earth fault currents flowing through the earth mat will increase, causing a proportionate increase in the voltages induced onto parallel telecommunication circuits. This will also cause the EPR on the power earth mat at the other end of the earth fault circuit to increase for this particular earth fault. [If the maximum EPR on this “other” earth mat is due to a different fault, this maximum EPR value may remain unaffected.]
2. While the maximum EPR on the earth mat will decrease, this is more than compensated for by the increased “size” of the earth mat pushing out the proportionate earth mat EPR contours (i.e. the 50%, 25%, 10% x  $EPR_{\text{earth mat}}$  contours). The nett effect of this will always be to increase the EPR at

any location outside the expanded earth mat. This effect is illustrated in the Worked Example in Appendix F.

Clearly the converse of this also applies. Any induction hazard to telecommunication networks, and any EPR levels at the location of nearby telecommunication plant (outside the power system earth mat), will be decreased if the size of the power system earth mat is reduced (i.e. if its earth resistance is increased). [This will however increase the EPR on the earth mat, and the corresponding step and touch voltages.]

The above comments apply to situations where the earth mat resistance is reduced by “expanding” the local earth mat. However, if the “effective” earth mat resistance is instead reduced by bonding a remote earthing system to it (e.g. via a cable sheath, or via an overhead earth wire (bonded to pylons)), this could result in the EPR on the earth mat being significantly reduced, without the proportionate earth mat EPR contours around the (local) earth mat being “pushed out” significantly. The net effect of this could be a lower EPR at the location of nearby telecommunication plant. The downside of this arrangement is that any EPR appearing on either earthing system, will also be conducted to the other earthing system (i.e. the maximum EPR level will be reduced, but it will also now appear at many more locations (i.e. be more widespread)).

The one area where this method does have major use for mitigating EPR, is in the bonding together of all MEN systems (and zone substations) in a “large” urban area, to make up a “giant” extensive MEN/HV earthing system. Usually the net effect of this is to reduce the maximum EPR for any earth fault within this area to substantially less than the EPR hazard limit voltage of 430Vrms (650Vrms for durations < 0.5s), thereby “solving” all EPR hazard problems in the whole area.

#### **1.4.7 Increase Zero Sequence Impedance using a Neutral Impedance**

The neutral of the supply transformer may be connected to earth through an impedance. The four methods of impedance earthing are as follows:

- Unearthed
- Resonant Earthing
- Reactive Earthing
- Resistive Earthing

These four methods are considered in this document, together with the traditional solid earthing.

Neutral impedance earthing reduces any earth fault currents (usually substantially), which in turn reduces both any consequential EPR’s, as well as any induced voltages on parallel telecommunication lines/cables.

By its very nature it treats the “cause” rather than the “symptoms” of EPR and induction hazard. Consequently, this method of mitigating EPR and/or induction offers a number of major advantages. These include:

- (1) Dispensing with the need for any ongoing monitoring system which would otherwise be necessary to ensure any future additions/changes to the telecommunication plant in that area do not compromise the initial mitigation arrangement.

There is a significant risk that at some time in the future this could be overlooked, or the existing mitigation arrangement compromised. Neutral impedance earthing completely removes this risk/ongoing monitoring liability.

- (2) Solving, in addition to the immediate known EPR problems of concern:
  - other existing EPR and/or induction hazard problems, whether known or unknown, and
  - any future EPR and/or induction hazard problems

It is therefore a much more robust and “future-proof” solution, which is considered in detail in the remainder of this document.

## 2 Definition of Terms and Drawing Symbols

Definitions of terms in the Electricity Regulations 1997, and the Electricity Act 1992 apply unless otherwise stated in this Section. Symbols have the meanings in I.E.C. Publication 617 unless defined more specifically under “*Symbols used in Schematic Diagrams*” below.

### ***Distribution Substation***

An *HV Station* which receives power at *high voltage* and transforms it to *low voltage* for supply to consumers.

### ***Earth Electrode***

A conducting element or electrically bonded group of conducting elements in electrical contact with the earth designed and generally used for dispersing electric currents into the earth.

### ***Earthing System***

A conducting electrode usually made of steel rod, steel strip, copper wire, or copper strip, buried in the body of the earth for the purpose of conducting electric current from the connected plants’ earthing conductors to earth.

### ***HV Station (including Distribution Sub-Station) Earthing System***

An electrically bonded arrangement of conductors including earth electrodes buried in the earth to which metallic fixtures and fittings of the *HV Station* are connected to conduct fault current from the station *high voltage* conductors to the earth.

### ***HV Structure Earthing System***

A conductor in contact with the earth which forms part of a structure supporting *HV* plant (e.g. a steel pole or transmission tower) or an earthing conductor or a small number of conductors in contact with the earth associated with an *HV* supporting structure.

### ***Earthing System Potential Rise (EPR)***

The potential with respect to remote earth potential to which the *earthing system* rises due to the flow of fault current between the *earthing system* and earth.

### ***Earth Potential***

The actual potential of the earth, with respect to *remote earth* potential, at any point outside the perimeter of the *HV Station earthing system* or near a *HV Structure earthing system*.

### ***Hazard Zone***

For the purposes of this Guide, a *hazard zone* is defined as that part of the area around an *earthing system* which is bounded by a contour joining all points of earth potential equal to the maximum acceptable voltage limit below which no special precautions to protect personnel and plant need be taken.

### ***High Voltage ( HV )***

A voltage exceeding 1000 V a.c.

### ***HV Station***

An electric power station, substation or switching station in which plant operates at *high voltage* and which is connected to other *HV Stations* by overhead lines and/or underground cables.

### ***Low Voltage ( LV )***

A voltage not exceeding 1000 V a.c.

**Remote Earth.**

The potential of an *earthing system* in a body of earth which is sufficiently far away from any current flowing in the body of earth so as to be unaffected by such current flows.

**Voltages**

Voltages given in this guide are root mean square (RMS) values for alternating current, and average values for direct current unless otherwise stated.

**Symbols Used in Schematic Drawings**

The following symbols have the meanings specified below in this Guide.

Remote  
Earth

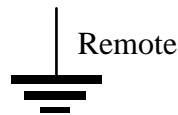

HV Station Earthing  
System with Earth  
Resistance  $R_e$

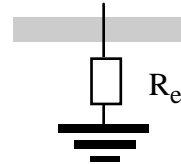

Other symbols have the meanings given in I.E.C. Publication 617 (1983)

**Glossary of Abbreviations Used in this Guide**

EPR	Earth Potential Rise
HV	High Voltage (voltage exceeding 1000V a.c.)
LV	Low Voltage (voltage not exceeding 1000V a.c.)
NER	Neutral Earthing Resistor or Reactor.
MEN	Multiple Earthed Neutral

### 3 Devices and Methods of Earthing

#### 3.1 Overseas and NZ Practice

New Zealand prior to about 1980, almost always used solidly earthed neutrals on transformers. Overseas electricity authorities have on the other hand employed a wide range of earthing techniques, as summarised below.

##### 3.1.1 United Kingdom (UK) Practices

According to an Electricity Council (UK) report, about half of the HV transformer supply neutrals (late 1970's) were impedance earthed.

Techniques employed include:

- Liquid resistors - water tank type devices, containing an electrode system in a salt solution.
- Metallic grid resistors - cast iron or stainless steel resistance elements mounted on a suitable frame for indoor or outdoor mounting.
- Oil insulated, air cored (untuned) reactors. Mounted in steel tanks, similar to a transformer enclosure.
- Oil insulated, iron cored, tapped and tunable reactors, more normally referred to as "Arc Suppression Coils" (ASC) or "Peterson Coils".

Liquid resistors up to 20 ohms in value are traditionally installed at system voltages of 33 kV and above, but 11 kV applications are also in service up to 4.5 ohms per transformer or 6.3 ohms for a single NER per substation. In more recent times (c1985) a number of UK Area Electricity (Distribution) Boards (since privatised) have opted to install 8.5 ohm reactors on 11 kV systems, with one per transformer unit, this value of reactance being independent of transformer capacity. The use of Arc Suppression Coils in the UK appears to be limited to rural overhead line networks in four Area Boards.

A number of coal mines in the UK with 6.6 kV underground networks employ neutral resistance earthing. Some of the more recent of these use a ceramic/carbon type of resistor element.

In the UK the trend is away from liquid resistors at the distribution voltage levels 11 kV and below. They are bulky, expensive to construct and maintain. Compact reactors, as employed by the Eastern Electricity Board since 1975, are quite popular.

The Midlands Electricity Board for example also have a programme of reactor installation in favour of the more conventional resistors.

The main reason for applying impedance earthing in the UK, in recent installations, is to moderate the level of earth fault current and reduce electrical stress in earth fault current return paths such as cable sheaths, joints, connections, etc.

Any reduction in interference with telecommunication system networks resulting from impedance earthing is generally regarded as a secondary benefit.

This is due mainly to the low earth resistivity generally found in the UK, the extensive underground cable power networks and the cross country nature of their overhead high voltage power lines.

Arc Suppression Coils, first introduced in the 1930's, were restricted to rural overhead networks in a bid to improve the transient fault clearing ability of such systems without the need for circuit breaker operation. Fault location is assisted in many cases by the detection of 5th harmonic current flow direction in the faulted network with "tuned" relays.

### 3.1.2 European Practices

In countries such as Sweden, Germany, Switzerland, France and others, impedance earthing in the form of Arc Suppression Coils (ASC's) or "Petersen Coils" are commonly used to maintain continuity of supply under single phase earth fault conditions.

Extensive underground cable networks are "compensated" by large ASC's with ratings of up to 800 amps.

These devices are massive and are equipped with automatic inductance adjustment control equipment to allow for external power network changes (in system capacitance).

Fault location in such systems is in some cases detected by the injection of audio frequency (ripple injection) signals at the faulted feeder substation busbar. The direction of audio current flow is used to determine the faulted feeder. Faults are often "left on" for extended periods until convenient for repairs to be made.

### 3.1.3 Australian Practices

The power distribution networks in Australia have in the past generally been solidly earthed at transformer neutrals.

In the State of Victoria, a massive programme of neutral resistance earthing was proposed (c1992) for the then State Electricity Commission of Victoria's (SECV's) 66/22kV zone substations (200 plus).

The NER installation programme was also associated with the adoption of a Combined Multiple Earthed Neutral (CMEN) system whereby every concrete power pole carrying HV conductors was to be bonded to the Low Voltage Multiple Earthed Neutral conductor where available on the same pole.

The objective of the SECV programme was primarily to reduce Touch potential hazard to members of the public from concrete power poles but also to reduce the hazard to telecommunication system users, staff and plant through reduced Earth Potential Rise and Low Frequency Longitudinal Induction.

The initial installations at 22 kV were to be implemented using stainless steel grid type NERs, one per zone substation with a value of 8 ohms with a 10 second rating of 1500 amps.

## 3.2 Solid Earthing

The purpose of an earth in a power system is to control the level of voltage rise in the network and to enable faults that do occur to be quickly identified and isolated.

Characteristics of the solidly earthed system are:

- High single phase to earth fault current.
- Good earth fault relaying.
- Minimisation of transient over-voltages.
- Voltage rise on healthy phases during a phase to ground fault is minimised.
- Cheapest form of earthing, minimal maintenance.

The high single phase fault currents in NZ systems have been a major contributing factor in causing the EPR and interference with Telecom circuits. Generally overhead reticulation has no earth return conductor and so the fault currents use the earth as a return path.

High return current does mean that there is ample current to operate protection relays and also assists protection discrimination. The magnitude of the fault current can also cause considerable damage at the point of fault, which may assist fault location. High fault



currents may, however, also result in greater damage to power system equipments such as imperfectly made connections.

Where cable sheaths form part of the earth return path they must be rated to withstand the high fault current.

In recognising the high levels of earth fault currents, some overseas power authorities that have traditionally used solid earthing have adopted impedance earthing.

### 3.3 Unearthed Systems

Under normal operation an unearthed power system behaves the same as an earthed system. The star-point remains at earth potential provided that the line to earth capacitance is equal in all phases. When an earth fault occurs, current will only flow as a result of the capacitance to earth of the healthy phases.

The larger the network the greater the capacitance, therefore, the greater the fault current. For example, a typical unearthed 11 kV system would have earth fault current levels of approximately 10-50 amps as compared to a solidly earthed system at 10 kA - 20 kA.

The unearthed option is cheap and simple and allows transient earth faults on overhead systems to be self clearing. Arcing earth faults and the difficulty of identifying the faulty feeder are the main disadvantages.

Beyond certain current levels, capacitive current is usually compensated by installing an arc suppression coil.

All the equipment for an unearthed system must have its insulation designed on the basis of the neutral rising to and sustaining full network voltage. For a high voltage network, e.g., 220 kV, this is costly.

### 3.4 Resonant Earthing (Petersen Coils, Arc Suppression Coils, Earth Fault Neutraliser Earthing)

A Petersen Coil is connected between the neutral point of the system and earth, and is rated so that the capacitive current in the earth fault is compensated by an inductive current passed by the Petersen Coil. A small residual current will remain, but this is so small that any arc between the faulted phase and earth will not be maintained and the fault will extinguish. Minor earth faults such as a broken pin insulator, could be held on the system without the supply being interrupted. Transient faults would not result in supply interruptions.

Modern installations are designed to automatically tune themselves as the network length varies due to operational switching, etc.

Although the standard 'Peterson coil' does not compensate the entire earth fault current in a network due to the presence of resistive losses in the lines and coil, it is now possible to apply 'residual current compensation' by injecting an additional 180° out of phase current into the neutral via the Peterson coil. The fault current is thereby reduced to practically zero. Such systems are known as 'Resonant earthing with residual compensation', and can be considered as a special case of reactive earthing.

Resonant earthing can reduce EPR to a safe level. This is because the Petersen coil can often effectively act as a high impedance NER, which will substantially reduce any earth fault currents, and hence also any corresponding EPR hazards (e.g. touch voltages, step voltages and transferred voltages, including any EPR hazards impressed onto nearby telecommunication networks).

### 3.5 Resistive/Reactive Earthing

This is a simple means of reducing earth fault currents. In many cases only one NER per substation has been used. Modern NERs are compact and require almost no maintenance. Initially, liquid resistors were used to provide neutral impedance. These suffered from bulky size and the need for regular checking of the electrolyte resistance

and in some areas heating is required to prevent the liquid freezing. The cost of a resistor/reactor increases with rating, hence it is important to optimise this in relation to earth fault protection settings.

### 3.5.1 Reduction of Earth Fault Current

The reduction of earth fault currents as a result of installing NER's is not only beneficial because of the reduced interference with telecommunication plant, but is also beneficial to power companies because both mechanical and thermal stress on equipment are reduced. Section 12 outlines the general AC network benefits of installing NER's.

### 3.6 Use of Earthing Transformers

For cases where there is no neutral point available (e.g. for a delta winding), an earthing transformer may be used to provide a return path for single phase fault currents. In such cases the impedance of the earthing transformer may be sufficient to act as an effective earthing impedance. Additional impedance can be added in series if required. A special 'zig-zag' transformer is sometimes used for earthing delta windings to provide a low zero-sequence impedance and high positive and negative sequence impedance to fault currents. Section 8 provides further information on the application of earthing transformers to networks supplied via delta connected transformers.

## 4 Current Considerations

### 4.1 Source Fault Levels

One of the principal effects of introducing an NER into a power system is the resulting stabilisation in earth fault current levels. This is because typical values of NER impedance used are relatively large, compared with the system source impedance. If for example, an existing 11 kV substation has a 120 MVA (1 ohm) source, and a 20 ohm NER installed, the earth fault level would be of the order of 315 amps (this assumes zero fault resistance, line impedance and substation earth mat resistance for the sake of simplicity).

If, however, the source fault level was then doubled to 240 MVA, the earth fault level would increase by less than 1 amp. Even assuming an infinite infeed (zero source impedance), the earth fault level would only increase to 317.5 amps. It should be appreciated from the foregoing example that as far as earth faults are concerned, the gradual increase of source fault levels from existing, right up to design levels, will have little effect. This of course would not be the case with interphase faults.

### 4.2 Earth Fault Current Path

Including the effect of substation earth mat resistance, line impedance, fault impedance (if any) and earth resistance at the fault position will decrease the theoretical maximum earth fault level given in the previous paragraph. The following formula, which includes these effects, may be used to calculate fault current ( $I_f$ ):

$$I_f = \frac{3V_s}{2(Z_{1s} + Z_{11}) + Z_{0s} + Z_{0l} + 3(R_{e1} + R_{e2} + R_{ner} + R_f)} \quad \text{Eqn 4.1}$$

where

$R_{ner}$	= Value of Neutral Earthing Resistor.
$Z_{1s}, Z_{0s}$	= Source positive and zero sequence impedances.
$Z_{1l}, Z_{0l}$	= Line positive and zero sequence impedances.
$R_{e1}$	= Source earth resistance.
$R_{e2}$	= Resistance to earth at point of fault.
$R_f$	= Assumed "fault resistance".
$V_s$	= Phase - Neutral system voltage.

This can be simplified to the following, where the earth resistances and neutral earth resistance are large compared to the source and line impedances:

$$I_f = \frac{V_S}{R_{e1} + R_{e2} + R_{ner} + R_f}$$

For a solid fault,  $R_f = 0$  and the equation simplifies to:

$$I_f = \frac{V_S}{R_{e1} + R_{e2} + R_{ner}} \quad \text{Eqn 4.2}$$

This is an approximation, as it assumes a zero source impedance (an infinite infeed) and short lines. Accuracy is usually within +10% of the exact value, for HV faults close-in to a substation where a relatively large value NER is located. HV substation earth mat resistances are normally low, (e.g. less than 1 ohm). This often requires an extensive earthing system.

Low values of distribution system earthing resistance are sometimes difficult to obtain in rural applications, where extensive interconnected LV neutrals are not practicable.

The resistance to earth of LV MEN neutrals must be sufficiently low to ensure any fittings connected to neutrals do not introduce a danger to persons and property, and also sufficiently low to ensure the correct operation of the protective devices which will disconnect supply. Since typically the method of earthing the LV power system consists of a number of driven rods, the earth resistance will be determined by local soil resistivity and may have a significant seasonal variation.

Fault resistance may vary considerably depending upon the nature of the fault, e.g. solid, arcing, contact with trees or hedges. The latter two categories are unlikely to present problems as regards EPR, but are often difficult to detect from a protection sensitivity point of view. The only impedance to true earth for a solid (onto earthed metal work) fault is the earth resistance at the point of fault. In the case of an arcing fault, the arc itself introduces an additional impedance into the fault loop. This is usually taken to be resistive and an empirical formula for arc resistance is generally used as follows:

$$R = \frac{1905L}{I^{1.4}} \quad \text{Eqn 4.3}$$

where: R = arc resistance in ohms.  
L = arc length in metres.  
I = arc current in RMS amps.

This is the A R Van C Warrington Formula (converted to metric units).

In a typical 3 wire HV overhead power system, all of the fault current return path from the fault point to the source is through the general mass of earth, returning to the source neutral via the source substation earth resistance. It may be seen by inspection of the formula for earth fault current, that the basic limitation (stabilisation) of the fault current is provided by the NER.

In many cases, the values of  $R_{e1}$  and  $R_f$  could be less than 1 ohm and may be neglected, hence the other predominant parameter is the earth resistance at the point of fault  $R_{e2}$ .

Reduction in this earth resistance will reduce EPR at the point of fault, but at the same time, increase the earth fault current and hence also the EPR on the source substation earth mat.

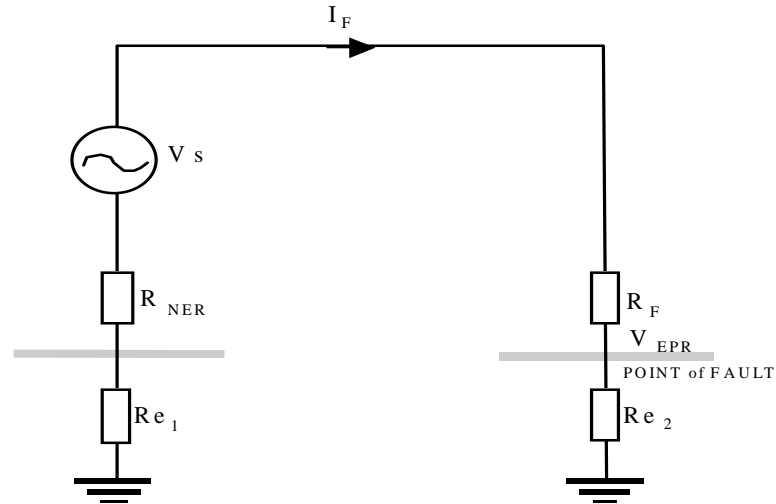

**FIG 4.1 NER in Earth Fault Path**

$$\begin{aligned}
 V_{EPR} &= I_F \times R_{e2} \\
 &= \frac{V_S}{(R_{NER} + R_{e1} + R_{e2} + R_F)} \times R_{e2} \\
 &\cong V_S \times \left( \frac{R_{e2}}{R_{NER} + R_{e2}} \right)
 \end{aligned}$$

**Eqn. 4.4**

where  $R_{e1}$  (source impedance components) and  $R_F$  (fault arc or contact resistance) are both zero, or very small.

#### 4.3 Effect of an NER on EPR

Referring to Fig 4.1 and associated equation 4.4, it can be seen that the NER and the earth resistance at the point of fault form a voltage divider network.

The EPR at the point of fault can therefore be reduced by increasing the NER value; however this should not be increased indiscriminately since it may have an adverse effect on the ability of earth fault protection to perform satisfactorily.

In order to appreciate the effect an NER has on EPR in a typical 33/11kV power distribution system, equation 4.1 has been evaluated numerically for a typical overhead radial system.

The results are given in Fig 4.2.

#### 4.4 Effect of an NER on Magnetically Induced Voltages

The introduction of additional impedance into the earth fault path will reduce fault current magnitude and hence the amount of magnetically induced voltage.

This has been found to have a more significant benefit in sub-transmission systems (22kV, 33kV, 50kV and 66kV) where parallel exposures with Telecom cables are often of greater length, and the earth resistance at the point of fault  $R_{e2}$  (the downstream substation earth mat resistance) is relatively low. In these situations an NER can often substantially reduce the maximum earth fault currents, and hence also substantially

reduce any magnetically induced voltages on telecommunication conductors. In 11kV urban distribution systems magnetic induction problems are generally of lower magnitude than EPR problems.

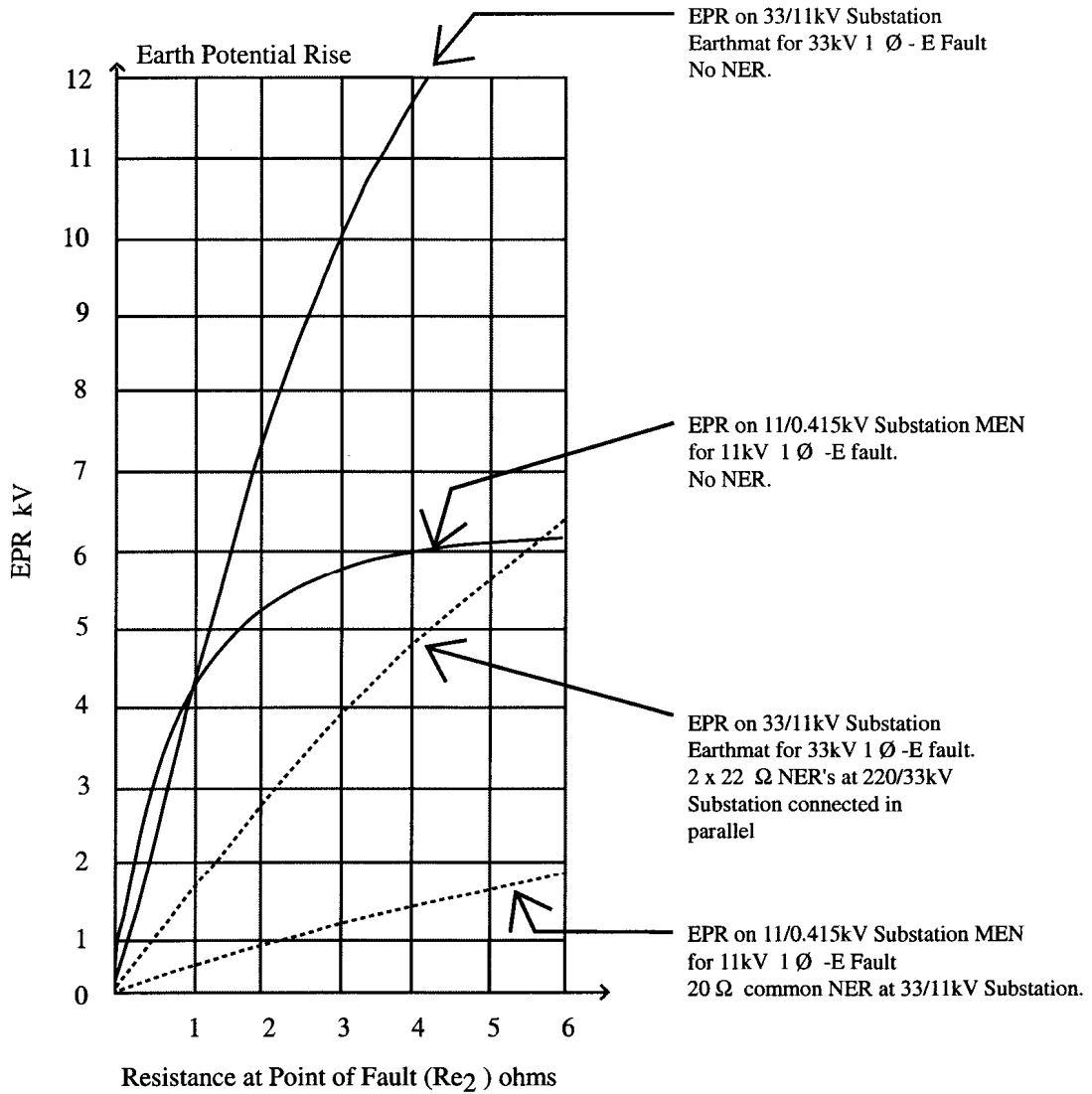

**FIG 4.2 Effect of NER on EPR**

## 5 Voltage Considerations

### 5.1 Introduction

One of the primary factors in making a decision as to how to (and whether to) earth the neutral point of a power system is the limitation of transient over-voltages generated within a network. Some of the more common sources of over-voltage on a power system are the following:

- Lightning.
- Switching surges.
- Electrostatic.
- Contact with a high voltage system.
- Line-to-earth faults.
- Resonant conditions.
- Re-striking earth faults.

#### 5.1.1 Lightning

Surge arresters installed at the terminations of the incoming supply limit the surge voltages within the plant which result from strokes to the exposed supply lines. Where plant is supplied from a step-down transformer at a substation, surge arresters are desirable on the low voltage side of the transformer, since the leading edge of an incoming surge on the low voltage lines can be transferred differently to the power frequency voltages because capacitive inter-winding coupling may predominate rather than magnetic coupling.

#### 5.1.2 Switching Surges

Normal switching operations in the system can cause over-voltages. These are generally not more than three times normal voltage and are of short duration.

The over-voltages developed result from transient oscillation between the circuit capacitance and inductance.

More serious over-voltages can be produced by devices which interrupt by forcing the current to zero. Devices such as vacuum interrupters and current-limiting fuses must be carefully applied because of this prospective over-voltage problem.

Neutral earthing is not likely to reduce the total magnitude of over-voltage produced by lightning or switching surges. It can, however, distribute the voltage between phases and reduce the possibility of excessive stress on the phase-to-earth insulation of a particular phase.

#### 5.1.3 Electrostatic

Overhead open-wire lines may be subject to electrostatic over-voltages resulting from atmospheric conditions. A system earth connection, even of relatively high resistance, can effectively prevent electrostatic voltage build-up.

#### 5.1.4 Contact with Higher Voltage System

Contact with a higher voltage system may be caused by one of the following:

- A broken higher voltage conductor falling on a lower voltage conductor where both lines cross or are carried on the same poles.
- Breakdown between the high- and low-voltage windings of transformers; these can cause other failures of insulation, possibly at several points.

An effectively earthed low-voltage system, though experiencing high values of fault current during the above conditions, would hold the system neutral close to

earth potential. Thus the over-voltages to earth on the lower voltage side would be greatly reduced.

### 5.1.5 Line-to-Earth Faults

A common case of sustained over-voltage on an unearthed system arises when one phase of a three-phase system becomes earthed. In such a case the insulation of the other phases is subjected to a voltage to earth 73% above normal.

A solidly earthed-neutral system could not reach this level of over-voltage. While 73% over-voltage seldom approaches the insulation levels of equipment and circuits, the cumulative effect of repeated higher than normal voltage stresses may somewhat reduce insulation life.

### 5.1.6 Resonant Conditions

An unearthed system may be subjected to resonant over-voltages. With the high phase-to-earth capacitance of larger systems, there may be a condition of approximate circuit resonance during a line-to-earth fault.

The voltage to earth of the unfaulted phases will then be considerably in excess of normal line-to-line voltage.

An earthed-neutral system would prevent resonant over-voltage by holding the phases near to their normal voltages to earth.

### 5.1.7 Re-striking Earth Faults

Field experience and theoretical studies have shown that arcing or re-striking earth faults on unearthed systems can, under certain conditions, produce surge voltages as high as six times normal.

Neutral earthing is effective in reducing transient voltage build up from such intermittent earth faults by reducing neutral displacement from earth potential and hence reducing the destructiveness of any high-frequency voltage oscillations following each arc initiation or re-strike.

## 5.2 The Effect of Earthing Methods on System Voltages

### 5.2.1 Earthing the System Neutral

Most earthed systems employ some method of earthing the system neutral at one or more points. These methods detailed in Section 3, are:

**Solid earthing** (Section 3.2)

**Resonant earthing** (Section 3.4)

**Resistive/Reactive earthing** (Section 3.5)

Each method, as named, refers to the nature of the external circuit from the system neutral to earth, rather than to the degree of earthing.

In each case the impedance of the generator or transformer, whose neutral is earthed, is in series with the external circuit. Thus a solidly earthed generator or transformer may not furnish effective earthing to the system. If the source impedance is of a high value, the transformer capacity may be too small in comparison with the size of the system to be able to stabilize the phase to earth voltage levels when earth faults occur.

### 5.2.2 Effectively Earthed System

A system is effectively earthed when the impedance between system neutral and the earth is low enough to restrict the phase to earth voltages on the healthy phases during a phase-earth fault to not greater than 80% of normal line voltage.

A system is considered to be effectively earthed when for all portions of the network of concern, the following reactance and resistance conditions apply:

$$0 < X_0/X_1 < 3$$

and

$$0 < R_0/X_1 < 1$$

where  $X_0$ ,  $R_0$  are the respective zero sequence reactance and zero sequence resistance of the network, and  $X_1$  is the positive sequence reactance at the same point.

Transformer neutrals may be solidly earthed, but due to excess zero sequence impedance caused by low transformer capacity or transformer installations with neutral earth points too sparsely located, the system may still become non-effectively earthed.

The characteristics of solidly earthed and effectively earthed systems are outlined in Section 3. They minimise transient over-voltages and voltage rise on the healthy phases during phase-earth faults. See Figure 5.1.

### 5.2.3 Reactance-Earthed System

A system is regarded as being reactance earthed where the ratio of zero-sequence reactance  $X_0$  to positive sequence reactance  $X_1$  is greater than 3, but is less than the value necessary for resonant earthing.

This is generally considered to apply to systems where the  $X_0/X_1$  ratio is between 3 and 10. This includes systems with solidly earthed neutrals and systems where reactors are connected between neutral and earth.

The literature on system earthing advises that for reactance earthed systems, the  $X_0/X_1$  ratio should be kept below about 10. This ensures transient over-voltages are not excessive. This is equivalent to keeping the ratio of single phase to three phase fault current above about 25%.

With reactance earthed systems any phase to earth fault creates a greater shift in neutral point voltage and higher increase in healthy phase voltage than with an effectively earthed system. This requires equipment purchased for such a system to have a higher insulation level than that needed for an effectively earthed system.

### 5.2.4 Resonant-Earthed System

Resonant earthing (Peterson Coil) is a special case of reactance earthing in which the capacitive current is tuned or neutralized by a neutral reactor. Care must be taken to keep the Peterson Coil tuned to the system capacitance to minimise the development of transient over-voltages, because the combination of neutralizer reactance and line capacitance constitutes a parallel resonant circuit.

### 5.2.5 Resistance-Earthed System

In general, resistance earthed systems have lower earth fault currents than effectively earthed or reactance earthed systems. This is necessary to limit the power loss in the neutral earthing resistor. The low fault currents can be beneficial to earthing grids and earth connection designs, and as well lessen any interference effects with neighbouring communication systems.

To avoid any serious transient over-voltage problems, the value of neutral resistance should lie within the boundaries:

$$2X_0 < R_0 \leq X_{c0}$$

where  $X_{c0}$  is the zero sequence capacitive charging reactance of the network ( $X_{c0}$  can be calculated). The need to ensure satisfactory relay operation for earth



faults may dictate use of a lower value of neutral resistance than indicated by the above boundary limits.

### 5.2.6 Unearthed System

The main advantage of an unearthed neutral system is its ability to sustain a single earth fault without interruption. The insulation of all equipment must be designed on the basis of full and continued neutral displacement. For HV systems this results in relatively high costs. Relaying is particularly poor and as well the system will be subject to high transient voltages such as caused by arcing earth faults.

## 5.3 Transient Effects

The over-voltage situations described above have been determined by symmetrical waveform analysis. Section 5.3.1 includes curves for determining overvoltage factors (known internationally as earth fault factors) applicable to particular values of  $R_1/X_1$  and are presented in a very useful format. In practice the individual phase values of over-voltage can vary from perfectly symmetrical to completely offset. The highest offset occurs when the current change at fault initiation is a maximum. The offset then decreases to zero at a rate determined by the X/R ratio of the power circuit at the fault. A highly inductive circuit will not only have maximum offset when the fault occurs close to voltage zero, but it will also have the most prolonged duration of offset.

In general, however, the resulting fault current is not fully asymmetric and rarely is the DC offset factor greater than 1.4. The fault current (initial magnitude and subsequent wave shape) has a direct relationship to the level of EPR which will be experienced. For these purposes it is quite common practice to use a factor of 1.2 to 1.5 times the maximum symmetrical value to accommodate transient conditions. The use of this factor has been confirmed by over-voltage levels experienced in the field.

Whilst the conditions of maximum fault current offset will lead to maximum EPR values, this condition (i.e. fault near voltage zero) is an unlikely time for insulation failure, compared to one taking place at peak voltage. Therefore, for power network insulation co-ordination, the use of factors of 1.2 - 1.5 are conservative. The use of a factor of 1.5 times the symmetrical value calculated based on sub-transient machine reactances should be adequate for estimating the maximum instantaneous over-voltages which may be experienced during transient conditions.

The inclusion of neutral earthing impedances will limit the total fault current and therefore EPR. However, the instantaneous neutral voltage displacement will be increased. Appendix A includes an indication of the effects different values of neutral resistance have for specific network conditions.

Examination of particular cases of equipment damage has suggested the theoretical possibility of a very fast transient EPR effect (i.e. above 1 kHz). This is considered in detail in Appendix B, which concludes that there is no correlation between such fast transient effects and the damage observed to date.

### 5.3.1 Determination of Temporary Over-voltages due to Earth Faults

This section is reproduced from IEC71-2 Annex B (see Acknowledgement following forward). Figures B.1 - B.5 in Annex B are reproduced in this document as Figures 5.1 - 5.5 respectively.

The earth-fault factor is at a given location of a three-phase system, and for a given system configuration the ratio of the highest r.m.s phase-to-earth power frequency voltage on a healthy phase during a fault to earth affecting one or more phases at any point on the system to the r.m.s phase-to-earth power frequency voltage which would be obtained at the given location in the absence of any such fault (see definition 3.15 of IEC 71-1).

The earth-fault is calculated using the complex impedances  $Z_1$  and  $Z_0$  of the positive and zero sequence systems, taking into account the fault resistance  $R$ . The following applies:

$Z_1 = R_1 + jX_1$  : resistance and reactance of positive and negative sequence system,

$Z_0 = R_0 + jX_0$  : resistance and reactance of zero sequence system

(The earth-fault factors are calculated for the location of the fault).

**[Explanatory Note - The earth fault factor ( $k$ ) should be derived by**

1. calculating the ratios  $R_1/X_1$ ,  $R_0/X_1$ , and  $X_0/X_1$  at the location of the fault
2. selecting the Figure (from Figures 5.2 to Figure 5.5) whose  $R_1/X_1$  ratio (0, 0.5, 1 or 2) is closest to the above  $R_1/X_1$  ratio and
3. deriving the earth fault factor  $k$  from this figure using the above  $R_0/X_1$  and  $X_0/X_1$  ratios].

**Note:** It should be observed that in extended resonant-earthed networks, the earth-fault factor may be higher at other locations than the fault.

**Figure 5.1** shows the overall situation for  $R_1 \ll X_1$  and  $R = 0$

The range of high values for  $X_0/X_1$  positive and/or negative, apply to resonant earthed or isolated neutral systems.

The range of low values of positive  $X_0/X_1$  are valid for earthed neutral systems.

The range of low values of negative  $X_0/X_1$ , shown hatched, is not suitable for practical application due to resonant conditions.

For earthed neutral systems, figures 5.2 to 5.5 show the earth-fault factors as a family of curves applicable to particular values of  $R_1/X_1$ .

The curves are divided into regions representing the most critical conditions by the following methods of presentation:

- Maximum voltage occurs on the phase which leads the faulted phase, during a phase-to-earth fault.
- ..... Maximum voltage occurs on the phase which lags the faulted phase, during a phase-to-earth fault.
- ..... Maximum voltage occurs on the unfaulted phases, during a phase-to-earth fault.

The curves are valid for fault resistance values giving the highest earth-fault factors.

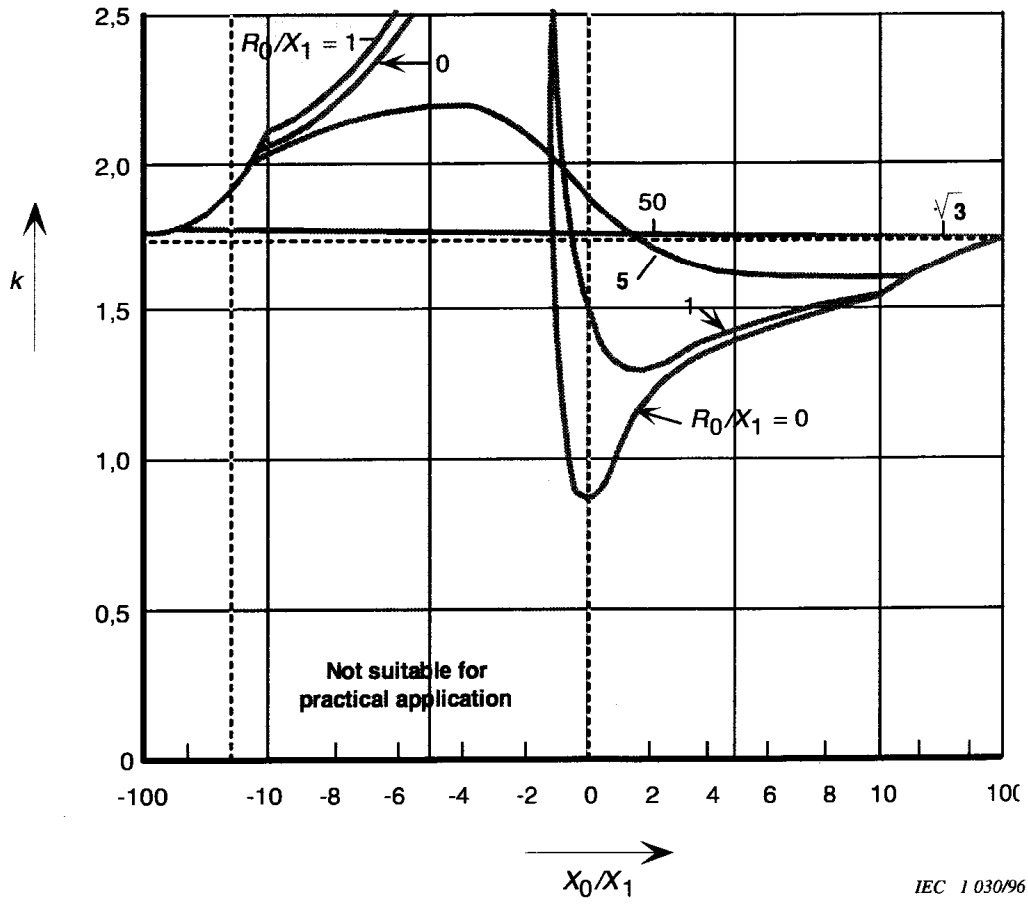

Figure 5.1 - Earth-fault factor  $k$  on a base of  $X_0/X_1$  for  $R_1/X_1 = R = 0$

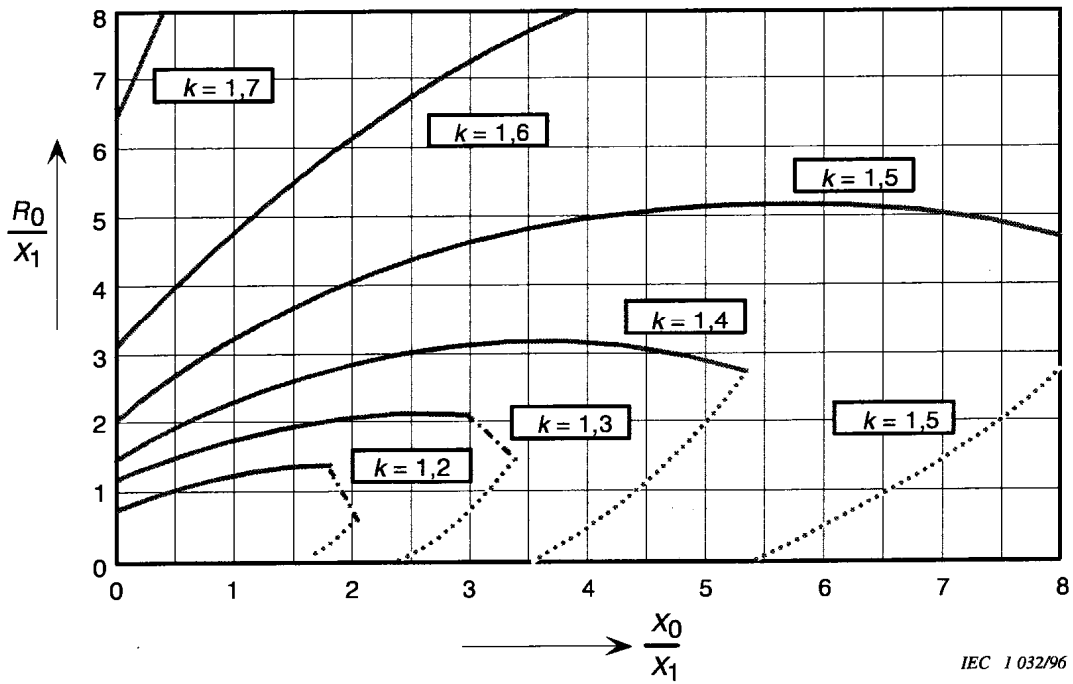
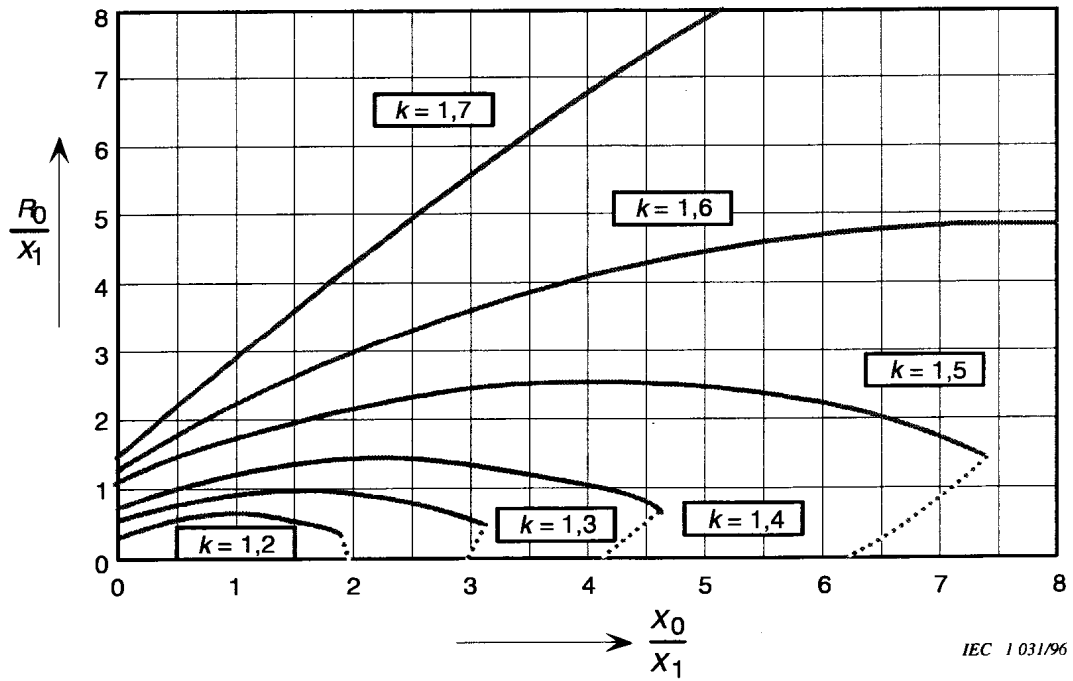
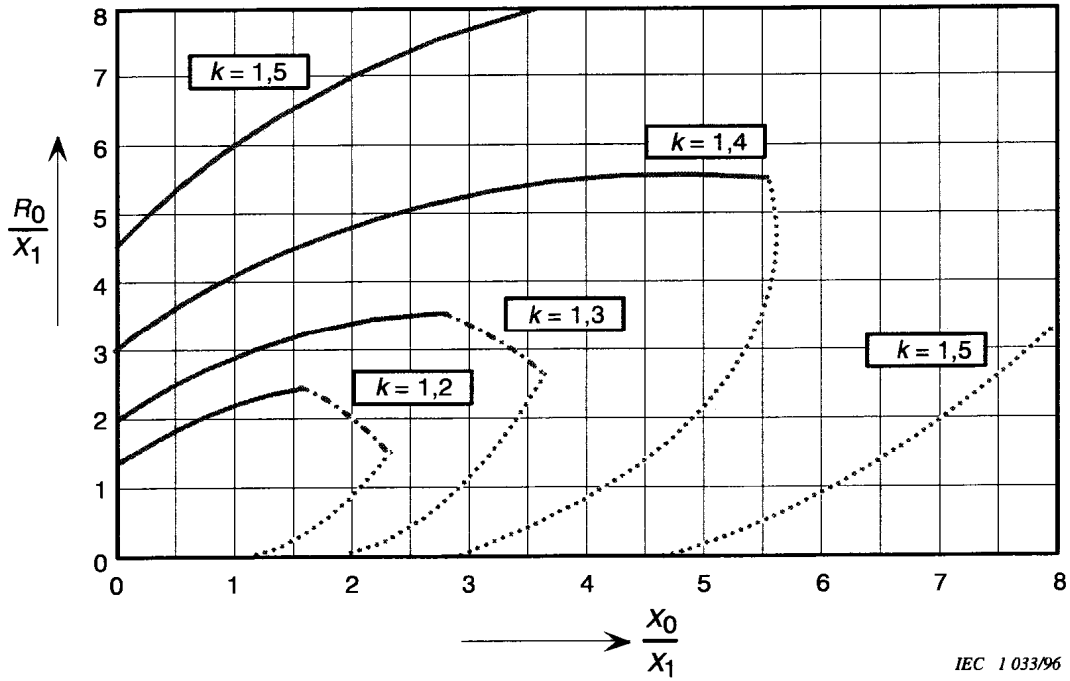

Figure 5.2 - Relationship between  $R_0/X_1$  and  $X_0/X_1$  for constant values of earth-fault factor  $k$  where  $R_1 = 0$

Figure 5.3 - Relationship between  $R_0/X_1$  and  $X_0/X_1$  for constant values of earth-fault factor  $k$  where  $R_1 = 0.5 X_1$



IEC 1033/96

Figure 5.4 - Relationship between  $R_0/X_1$  and  $X_0/X_1$  for constant values of earth-fault factor  $k$  where  $R_1 = X_1$

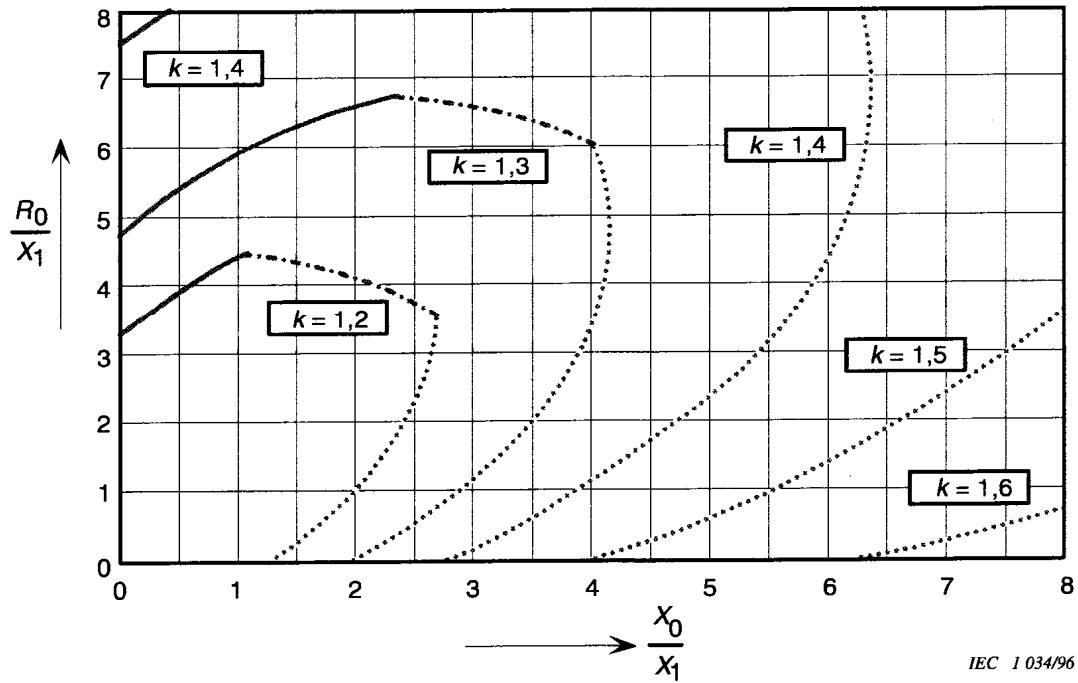

IEC 1034/96

Figure 5.5 - Relationship between  $R_0/X_1$  for constant values of earth-fault factor  $k$  where  $R_1 = 2X_1$

#### 5.4 Application in New Zealand

Effective earthing is used throughout the NZ 220 kV network where all primary insulated equipment is specified for the lower over-voltage withstand strength (BIL) of an effectively earthed system. At the supply busbars from which the Power Companies take their power, the maximum fault current is generally limited to 25,000 amperes. In some situations, particularly involving older switchgear, lower levels are adhered to for economic reasons.

Prior to about 1990, most 220 kV supply transformers were of the delta/star configuration, which ensured a direct star point connection for the LV (secondary) side. In general, no auxiliary means of restricting the secondary side earth fault current were employed, except in special cases. Islington Substation is an example of a special case where earthing resistors are installed on existing delta/star 220/33kV transformers to limit the 33kV earth fault current. This was done to protect NZ Telecom equipment.

The possibility of back energising an unearthed section of HV transmission system from a lower voltage supply bus can lead to hazardous over-voltages. This could occur for example if a section of the HV network became temporarily disconnected from the rest of the HV system, but remained energised from an LV generation source via a delta (HV) / star (LV) supply transformer. Local generation can provide a source of LV energisation.

It is Transpower policy to install 220/33kV supply transformers of star/delta configuration, with the 33kV delta winding earthed via earthing transformers.

The reasons for adopting this arrangement are:

- Star connected 220 kV windings provide additional 220 kV earth points thereby ensuring the 220 kV network is effectively earthed.
- The overall cost is reduced. The transformer costs are lowered because graded HV winding insulation can be used, although the costs of the earthing transformers and the slightly more complicated protection arrangements partially offset the reduced transformer costs.

The adoption of this arrangement results in the following:

- The LV earth fault current is restricted. Protection considerations require that this current be maintained at a level which ensures reliable detection by protection relays. If the earth fault currents are too low, the earth fault factor (see Section 5.3) may be too high and the risk of over-voltages increases. Since 1998 Transpower has standardised on an earth fault current value of around 500A, for overall economic reasons.
- Earth Potential Rise (EPR) on the station earth grid is reduced. Danger to personnel and telecommunication equipment is therefore decreased.

The disadvantage of resistance earthing is the greater voltage rise of the unfaulted phases during earth faults due to greater neutral displacement and consequently greater voltage stress on the insulation of not only new equipment but also existing equipment.

For generating systems a common method of earthing is to connect a single phase distribution transformer between the star point of the generator and earth, with a resistor connected across the secondary of the transformer. The value of the resistor is chosen to limit the earth fault current to the desired value (normally a small fraction of the three phase fault current, possibly to the generator full load current).

Where a feeder is connected to the generator busbar, a higher fault current may be needed to ensure transient voltage problems do not arise. This is generally accomplished by ensuring  $R_0 < X_{c0}$  for all network connections.

## 6 Protection Considerations

### 6.1 Introduction

Following installation of impedance earthing on a power system, two aspects of protection require consideration:

- Possible changes to network protection as a result of the addition of the NER.
- Protection for the NER itself and associated transformer(s). Although they form part of the existing network, it is convenient to regard the transformer(s) and NER as a composite group, since the NER protection will trip the transformer circuit breakers.

These two considerations are discussed below in the context of earth faults only. The addition of impedance earthing on a system does not affect phase faults, or protection performance for phase faults.

### 6.2 Changes to Network Protection

The consequence of adding impedance earthing onto a power system is to reduce the magnitude of earth fault current, for any earth fault.

There was very little statistical data on the range of earth fault current values experienced on NZ distribution systems up to 1988. However, as a result of increasing number of earth fault incidents resulting in damage to telecommunications plant in the Hornby area, Christchurch, a 20 ohm NER was installed at the distribution substation and subsequent fault performance was carefully monitored. Over the following 10 year period, earth faults on overhead 11kV feeders in the area averaged 20 Amps, and the presence of the NER had virtually no effect on sensitive earth fault protection set at 6 to 10 amps. Details of the 10 year study following the Hornby NER installation are covered in Appendix E.

Since it is not generally known how many faults go undetected prior to fitting an NER, it is difficult to accurately determine to what extent protection performance will be degraded after an NER is installed. A constructive approach is to ensure that following the installation of an NER, all earth fault protection is set to achieve maximum practicable sensitivity. It should not be assumed that this is the case at present. With modern relays and CTs, sensitivities below 5% of full load are practical although this may be limited by system characteristics.

Factors which affect earth fault protection sensitivity are discussed below:

- **CT Ratio**

This should be as low as practicable, consistent with load carrying requirements.

- **CT Errors**

Where the earth fault relay is energised from phase connected CTs, minor CT errors or unbalanced primary current (load or through-fault conditions) may result in spill current at the relay.

In general this is not a problem when a neutral CT is used although standing neutral currents are not unknown.

- **Relay Type and Setting**

If electromechanical relays are being used the minimum available setting may not provide the greatest sensitivity, i.e. the primary operating current of an earth fault protection scheme is often higher on the minimum relay plug setting than on an intermediate plug setting due to the effects of CT burden.

A modern (electronic) over-current/earth fault relay usually has a constant low value of ohmic burden throughout its setting range. This ensures that the associated CT will not have its magnetising current increased significantly during an earth fault.

- **System Capacitance Currents**

The setting of earth fault relays, particularly those in the sensitive earth fault (SEF) category, should include a consideration of system leakage and capacitance currents, under both normal load and fault conditions.

Under normal load conditions, primary unbalanced leakage or capacitance currents produce residual current, which will be a basic limiting factor in setting SEF protection.

Under fault conditions, imbalance of the system voltage will cause an unbalance in the capacitive current drawn in each phase of a feeder. It is possible for a healthy feeder to trip via SEF protection, due to unbalanced capacitive currents. In order to prevent such spurious tripping it is necessary to choose an SEF relay setting which will not respond to normal unbalanced capacitive currents.

Generally an SEF primary operating current of 3 times the steady state phase to earth capacitive current should be satisfactory. This setting may conflict with the requirement for optimum earth fault protection sensitivity. If extensive cable networks are involved, a compromise may be required between NER ohmic value, earth fault protection settings and discrimination with capacitive currents.

If the proposed SEF setting sensitivity is a problem on only one feeder, it may be possible to overcome this by adding sufficient time delay to that feeder's protection, whilst using an SEF setting below the capacitive current threshold recommended above.

Alternatively it may be acceptable to tolerate occasional spurious tripping, particularly if auto-reclose is fitted on the feeder.

- **Resonant Earthing**

Detection of the existence of an earth fault in a resonant earthed system can be carried out by measuring the neutral displacement. For an accurately tuned system this can detect the presence of very high impedance faults.

However, this will not tell you what feeder (or phase) the fault is on. Because by design there is very little earth fault current in a correctly tuned resonant earthed system, only the system capacitance currents remain and current operated methods of detecting and isolating earth faults will not work. The traditional method of isolating earth faults in resonant earthed systems uses a watt metric element in conjunction with measurement of the neutral displacement.

More sophisticated methods use measurement and analysis of the phase relationships of the initial voltage and current transients and/or measurement and comparison of the feeder admittances.

In situations where a Petersen coil with residual compensation is effectively used as a very high impedance neutral – earth impedance, if a single phase-to-earth fault occurs:

- The faulted phase effectively becomes the new earth reference for the HV distribution system.
- The voltage-to-earth on the two unfaulted phases increases to the phase-to-phase voltage. This should not be a problem if all the fittings are insulated to greater than the phase-to-phase voltage, rather than just the phase-to-earth voltage.
- The phase-to-phase voltages, and hence also the corresponding distribution transformer LV voltages, remain unaffected.

Consequently, it can be argued that all the relevant safety requirements in the Electricity (Safety) Regulations can be met without the need to trip these earth faults. Orion have done this for their Petersen coil with residual compensation at Darfield Substation. Initial earth faults are not tripped, and are normally fixed without any service interruptions. This greatly benefits the SAIDI and CAIDI fault statistics for the Darfield substation area.



If a second earth fault occurs on an unfaulted phase before the first fault is fixed, this will create a phase-phase fault (via earth). Because this will effectively bypass the Petersen coil and its current-limiting properties, this earth fault must be tripped. The Darfield Substation Petersen coil installation is configured to ensure this happens.

### **6.3 Protection of the NER and associated Transformer**

#### **6.3.1 NER**

An NER only needs to be protected from thermal overload. This may result from earth current flow arising from either repeated auto-reclose operations or the long term presence of small magnitude neutral currents which may occur due to high-resistance faults or system unbalances.

Protection against small continuous neutral current is relatively straightforward. A sensitive current operated relay with suitable time delay (to grade with feeder earth fault relays) will usually be adequate.

Repeated auto-reclose operations require the use of either a thermal replica type of relay or a slow resetting relay for satisfactory protection.

Relays of the “standby earth fault” (SBEF) type used in the UK fall into the latter category, having an inverse long time operating characteristic and long reset time.

The final choice of relay will depend on the thermal characteristics of the NER concerned. In this respect it may be prudent to seek advice from the NER manufacturer.

The neutral CT associated with the NER and transformer will generally supply both a “system” earth fault relay and an NER protective relay (alternatively it may be possible to perform these two protection functions with one relay, e.g. a SBEF relay). The neutral CT must however be located in such a position that it is always in-service, irrespective of the position of the resistor “service-bypass” switch.

Temporary earths inadvertently left in position may short out the resistor and/or CT. This situation could remain undetected for months, hence as far as is practicable the installation should be designed to discourage the application of temporary earths at such positions.

A warning notice should be provided in a prominent position to combat this possibility.

#### **6.3.2 Transformer Protection**

Consideration should be given to the effect of an NER installation on existing transformer protection. The main effect will be to reduce the ability of biased differential transformer protection (if fitted) to detect earth faults on the transformer LV windings. A significant part (the lower part) of the LV winding will become unprotected (for earth faults) by the biased differential protection.

The actual percentage of winding unprotected will vary, depending mainly on the value of earthing impedance. With typical values of NER impedance encountered (e.g. 5-20 ohms) it may be assumed that the biased differential protection cannot be relied upon to operate in the event of an LV winding earth fault.

A secondary but important effect of installing an NER on the LV side of a transformer, is that this will probably result in protection on the HV side being unable to respond to LV earth faults (e.g. HV over current). This back up protection function may therefore be lost.

The conventional approach to protecting a resistance earthed transformer winding is to use restricted earth fault (REF) protection. This can be combined with differential protection to operate off the same phase CTs, provided the

existing CTs have suitable characteristics. A neutral CT and auxiliary interposing CTs will also be required.

An alternative to this combined scheme is to use completely separate CT cores to drive the REF and differential protection respectively. However, it is unlikely that this additional cost can be justified, particularly on transformer sizes used on distribution systems.

REF relays are generally of the “high impedance” type, using either internal or external stabilising resistors. The relays are therefore calibrated in volts and a suitable setting voltage must be chosen which will provide optimum scheme sensitivity for in-zone faults and stability for out-of-zone faults.

To ensure fast operation for in-zone faults the voltage setting chosen should not be greater than half the CT knee point voltage. Overall sensitivity (primary operating current) of an REF scheme is mainly dependent upon the magnetising current drawn by all of the scheme CTs (in parallel) at the operating voltage of the relay. In general the better the quality of CTs used, the higher the permissible REF scheme sensitivity will be and vice versa. With the typical values of NER resistance mentioned above it should be possible to protect at least 85% of the transformer winding with an REF scheme.

Another possibility is the use of transformer tank or “Howard” protection. This operates on the same principle as earth frame leakage (EFL) protection, which has been fairly extensively used on switch boards. Due to limited application experience with Howard protection, it is difficult to draw conclusions on its usefulness, however it can be assumed to suffer from the same disadvantages as EFL protection.

- It can easily become inoperative due to the addition of a “new” earth path, such as an uninsulated cable sheath.
- It is difficult to retrospectively fit unless all cable glands are already lightly insulated from the tank, or glands made of non-conducting materials are used.
- Earthquake safety restrictions in NZ may present difficulties to the general scheme requirement for the transformer tank to be insulated from ground.
- Scheme sensitivity is limited by possible mal-operation on out of zone (non-tank) faults, due to some earth fault current flowing from earth directly to the tank and then through the tank earth fault CT. Because of this phenomenon, low current settings on the tank earth fault relay are not recommended and it is not therefore possible to cover all of the transformer winding for earth faults.

Notwithstanding the above comments, transformer tank protection should have the advantage of being relatively inexpensive and may therefore be a worthwhile consideration.

Protection for winding earth faults will also be given by a Buchholz relay and it is strongly recommended that such a device be fitted. Time delayed (back up) protection for transformer LV winding faults will also be provided by the system earth fault relay/NER protective device.

The NER will stabilise transformer winding earth fault currents, such that the current flowing up the neutral will vary linearly from zero at the neutral end up to a maximum at the HV end of the winding. The percentage of winding not protected is therefore equal to the relay primary (effective) setting, expressed as a percentage of the maximum fault current.

## 7 Design Criteria and Device Selection

### 7.1 Introduction

This Section deals with the design and selection of a neutral earthing impedance.

Table 7.1 attached, taken from ref 6 summarises the advantages, disadvantages and general effect of the five alternative methods of neutral impedance earthing. (See also ref 6)

The main purpose of a neutral impedance as covered earlier in this guide is to limit earth fault current.

### 7.2 Existing System Components

#### 7.2.1 General

In choosing to adopt an impedance earthing method of connection it is necessary to consider the ability of the existing system components to withstand the additional voltage stresses imposed during earth faults. In this respect it is appropriate to consider the test voltage applied to components either during manufacture or when installed, and how the ability of insulation which has been in service for some time will resist the NER impressed over-voltages.

As test over-voltages are applied for at least 1 minute (i.e. many times the normal fault duration) it can be reasonably accepted that such equipment will not be adversely affected by the introduction of an impedance in the Neutral-Earth connection, since the over-voltages with respect to earth which the NER creates on the sound phases of the power system and the neutral point where the NER is installed, are lower than the acceptance test values and of shorter duration.

Reference 7 considers in depth, transformers, switchgear and cables in relation to the relevant standards and test voltages. Information in this Section is extracted from this ref. 7.

#### 7.2.2 Transformers

Most transformers have been designed and tested in accordance with BS 171 or harmonised standards e.g. I.E.C. and CENELEC. Windings for 33 kV and below are almost always fully insulated.

As they are individual items, it should be possible to identify the relevant standards from the name plate. Test certificates may also be available.

The applicable factory test levels are as follows:

##### **BS 171:1936**

- **Non-lightning areas with directly earthed neutral**

Test level 1 kV plus 2.8 times terminal voltage to earth for 1 minute. This would give

Phase Voltage	Test Voltage
6.6kV	11.7kV
11kV	18.8kV
33kV	54.3kV

- **Non-lightning areas with unearthed neutral**

Test level of 1 kV plus 3.46 times terminal voltage to earth for 1 minute or test level of 1 kV plus 2 x highest terminal voltage to earth which may occur under fault conditions. The first option gives

Phase Voltage	Test Voltage
6.6kV	14.2kV
11kV	23kV
33kV	67kV

- **Lightning areas**

As above for unearthed systems.

### BS 171:1959

The AC test level in this case has been raised and simplified, and is:

System Highest Voltage	Power Frequency Test Voltage for 1 minute
7.2kV	22kV
12.5kV	28kV
36kV	70kV

### BS 171:1970

The AC test levels in this case have been maintained for transformers subject to impulse test and relaxed slightly for those which are not subject to impulse test.

#### Impulse Tested

System Highest Voltage	Power Frequency Test Voltage for 1 minute
7.2kV	22kV
12.5kV	28kV
36kV	70kV

#### Without Impulse Test

System Highest Voltage	Power Frequency Test Voltage for 1 minute
7.2kV	15kV

12.5kV	25kV
--------	------

**Summary for Transformers:**

As all these transformer tests are tests of major insulation, and as this is the only respect in which resistance earthing affects the transformers, there is little doubt that such transformers would perform satisfactorily on an impedance-earthed system. This assumes that the insulation has been maintained in good condition.

**7.2.3 Switchgear**

As for transformers, these items should be individually identifiable from name plate data, so their test standards can be ascertained.

The applicable factory test levels are as follows:

**BS 116:1952**

The AC test levels are:

At works:

System Highest Voltage	Power Frequency Test Voltage for 1 minute
6.6kV	17kV
11kV	27kV
33kV	76kV

At site:

System Highest Voltage	Power Frequency Test Voltage for 1 minute
6.6kV	15.2kV
11kV	24kV
33kV	68kV

**BS 5311:1976**

The AC test levels have been raised for switchgear for the lower system voltage levels and are:

System Highest Voltage	Power Frequency Test Voltage for 1 minute
7.2kV	20kV
12kV	28kV
36kV	70kV

### **Summary for Switchgear**

Again no problem should arise in utilising switchgear of reasonably modern design, on an impedance earthed system.

#### **7.2.4 Cables**

It can be difficult to reliably identify the relevant design and test specification for a power cable network as such circuits often contain cables of varying age, construction and original data may not be available. Often each circuit has a variety of cable sections laid at different times, sometimes separated by many years, and exact records may well be unavailable. Thus it may not be possible to ascertain the relevant standards to which they were manufactured.

The situation is further complicated by the presence of joints between each cable section. These are of a much more variable quality than the cables, due to varying materials, designs, craftsmanship and conditions during their construction, and/or later repair.

A further complicating factor has been the change from AC to DC voltages for cable testing.

In summary it appears that the majority of existing effectively earthed cable systems can be converted to impedance earthed systems with reasonable values of neutral impedance.

It can be assumed that the occasional presence for around a second of a transient over-voltage during fault clearance, will not materially affect the integrity of the cable insulation, nor shorten the life of the installation.

However, very detailed consideration of all the variations in standard specifications, etc, is contained in ref 7 which should be consulted for individual cases.

### **7.3 Impedance Value**

The selection of the impedance value will depend on the reason for the NER's installation. If the reason is to permit the use of non-sheathed (i.e. screened) extruded dielectric cables, the predominant factor will be the maximum fault current magnitude and duration that the screen is able to withstand.

If the purpose is to restrict EPR to reduce risk to persons, then the predominant factor will be the permissible "hazard" voltage.

In either case once the predominant factor is resolved, by considering the component values for the rest of the fault circuit, a required value of additional NER impedance to be provided can be calculated. Refer to equation 4.1.

In addition to considering the present existing values of system parameters, etc, an assessment of the likely changes during the expected lifetime of the NER should be made. This applies particularly to the source fault level.

Having selected an impedance value the next step is to carry out a detailed review of protection practices and settings (refer Section 6), to ensure the revised system is adequately protected and that the requirements of the Electricity Regulations are met.

### **7.4 Impedance Type**

#### **7.4.1 Resistors**

The basic requirement for an earthing resistor is that it should be able to dissipate the worst case quantity of energy during the time the fault current flows. Thus, in addition to the nominal resistance value, a total energy input, or alternatively a time rating for which the unit may pass current, must also be specified.

#### 7.4.1.1 Liquid Resistors

An early type of neutral earthing resistor (no longer favoured) was the liquid type. This consisted of a metal tank and electrodes suspended in an electrolyte formed by dissolving salts in water. The actual value of resistance is adjusted by varying the area of the electrode immersed in the electrolyte, as well as by varying the electrolyte salt strengths and mixtures.

Whilst adequate current/time characteristics can be readily obtained with this type of construction, there are a number of major drawbacks, which result in regular maintenance being required.

The electrolyte strength must be tested and adjusted as corrosion is likely to occur with such a solution, and in colder areas it may freeze. Hence an immersion heater and thermostat together with a low voltage power supply must be provided. This continued maintenance cost results in the lifetime (capitalised) cost of the installation being many times the basic purchase price.

One aspect of this type of resistor that should be noted is that the temperature/resistance characteristic is negative, i.e. as current flows through the resistor and it heats up, the value of its resistance decreases. This characteristic can be useful as under high fault impedance conditions an earth fault current flow may be below the protection relay setting, even on its most sensitive position. The current will therefore continue to flow and the NER will heat up, its resistance then drops allowing a larger current to flow which the relay can then detect.

#### 7.4.1.2 Solid Resistors

The most common form of solid resistor has typically been constructed of metal resistance elements supported in a frame with natural air cooling. Resistance elements are typically made from cast iron, steel, or stainless steel. Such resistors can be mounted outside and have low maintenance requirements.

A recent development is the ceramic/carbon solid resistor. These resistors are manufactured by blending carbon, high quality alumina and selected clays which after shaping are fired at high temperature in kilns with a controlled atmosphere. Resistors of the required value are produced by assembling a number of suitable basic units in a clamping frame. Energy withstand can be improved by the use of inter-unit cooling fins.

Whilst the basic units require mounting on suitable insulators and housing (e.g. in a weatherproof enclosure for outdoor use), they are effectively maintenance free, although routine testing would be advisable.

### 7.4.2 Reactors

In view of the problems outlined above with the original liquid resistors, a number of power companies have adopted reactors to provide the required impedance. However, there are additional problems caused by the resultant phase angle of the fault current. Two types of reactors have been employed; air insulated and oil insulated, both normally being air cored.

#### 7.4.2.1 Air Insulated Reactors

These units typically consist of wire coils on a concrete former and due to their physical size are mainly appropriate for outdoor switch yards. They are basically maintenance free, although, as for all outdoor equipment, corrosion prevention measures are necessary.

#### 7.4.2.2 Oil Insulated Reactors

In this case air cored coils are immersed in a steel tank containing normal insulating (i.e. transformer) oil. The maintenance of these units is similar to that of a normal distribution transformer.

### 7.5 Design for Reliability

It is essential that the neutral point of the supply remains earthed at all times, either directly or through an NER. This means that the mechanical integrity of any equipment forming part of an NER is of utmost importance.

Disconnection, or open circuit failure of an NER can have serious consequences for power system equipment. Power transformers are expensive items, and also are costly to repair if winding insulation is damaged because of neutral point over-voltage.

Electricity Industry Companies have so far preferred to use NER's comprising a parallel-series connection of resistor elements, arranged in a bridge type format, to provide a high level of inherent reliability in the operation of the NER (see example in Figure 8.2 (a)). An unforeseen open circuit in any part of the NER can only result in a change of resistance or reactance value the transformer neutral will remain earthed.

Earlier Electricity Regulations [1997.84(6)(b)] required impedance earthed systems to be so arranged that even if part of the connection is switched, the star point remains connected to earth either directly or via an impedance at all times. The Electricity (Safety) Regulations 2010 require every earthing system to be designed, installed, operated, and maintained to ensure earthing performance objectives are met, which would include reliable connection of the star point to earth either directly or via an impedance, for all foreseeable conditions.

### 7.6 Comparative Costs

For any given installation it is necessary to estimate the total cost of each alternative type of resistor or reactor, with allowance for the on-going maintenance charges. The lowest cost solution is likely to be a solid resistor, ceramic or metallic grid, with an arrangement with reactors (air then oil) next. Liquid resistors will generally be the most expensive alternative. In considering some designs (primarily air cored outdoor reactors) some allowance should be made for the cost of the space required.

In the early 1990's comparisons were made between the costs of installing stainless steel NER's, Ceramic type NER's and Water resistor NER's, for use in New Zealand on the 11kV network. These showed liquid resistors to be the most expensive and ceramic resistors the least expensive.

However there are very few manufacturers world-wide for ceramic resistors, whereas stainless steel resistors are much more readily available in New Zealand. As consequence, most NER's installed in New Zealand over the last 8 years have been stainless steel.

Indicative costs for installing a stainless steel NER are given in Appendix D.



Grounding Method		Effectively grounded	Resistance grounded	Reactance grounded	Resonant grounded	Isolated neutral
Condition						
Ground fault current		High, sometimes >3-phase s.-c. current	Reduced, larger than capacitive ground fault current	Reduced, considerably larger than cap. grd. f. current	Neutralized	Capacitive ground fault current
	Ground faults (sound phases)	Less than 0.8 times line-to-line voltage	Full line-to-line voltage, sometimes more	Between 0.8 times and full line-to-line voltage	Full line-to-line voltage	Full line-to-line voltage or slightly over
Over-volt-	Fundamental frequency	Unlikely	Unlikely	Unlikely	Unlikely	Possible
	Inverted ground faults	Avoided	Avoided	Avoided	Avoided	Possible
Transients	Arcing grounds					
	Switching surges	Lowest			Controllable	Highest
Lightning surges	Direct	No practical difference				
	Indirect	No neutral oscillation	Neutral oscillation suppressed			Neutral oscillation produced
Transient ground faults		Converted into short-circuit	Converted into controlled fault current	Converted into controlled fault current	Suppressed	Capacitive arc
	Damage to equipment on occurrence of L-G fault	May be serious	Reduced		Avoided	Appreciable
Circuit-breaker duty		Frequent operation, maintenance required	Frequent operation, duty eased for L-G faults	Frequent operation, maintenance required	Infrequent operation. Recovery voltage increased with L-L-G faults	Frequent operation maintenance required
	Ground fault relaying	Simple and satisfactory				Can be made satisfactory, usually restricted to indication

Table 5

Condition		Grounding Method		Effectively grounded	Resistance grounded	Reactance grounded	Resonant grounded	Isolated neutral
Lightning arrester duty and performance	In normal balanced operation	Duty below rating			Power follow-on current suppressed	Duty below rating		
	Gap stress during ground faults, in per cent $\sqrt{3} E_{ph}$	<80% but reaching 100% on loss of ground	100 to 105	100	100			100 to 105
	Protective value	Improved for 80% types	Normal					
Applicability of graded transformer insulation		Yes, if impulse voltage distribution controlled	To a moderate extent	Possible, if suitable impulse protection applied	To a moderate extent, if neutral impulse protected			
Switchgear insulation		Above 161 kV reduction in BIL	BIL for 100% lightning arresters					
Secondary effects of outages		Large percentage			Large percentage		Large percentage	
System stability under L-G faults		Special measures may be required	Usually improved	Improved	Good		Unreliable	
Service continuity		Not preserved without special measures						
Influence on system layout		Duplicate supply desirable						
Interconnection with systems grounded by other methods		Interconnected systems may have to be re-classified relaying may be influenced						
Operational procedure		Simple			Supervision of tuning required; occasional adjustment of tapings		Simple	
		Simple			Supervision of tuning required; occasional adjustment of tapings		Loses its character	

Table 5 contd

<b>Grounding Method</b>	<b>Effectively grounded</b>	<b>Resistance grounded</b>	<b>Reactance grounded</b>	<b>Resonant grounded</b>	<b>Isolated neutral</b>
<b>Condition</b>					
Telephone interference	Requires great care	Requires care	Requires care	Minor problem	
Radio interference	Lowest	Low		May be noticeable during sustained faults	
Danger to life in proximity of fault	Serious	Reduced	Reduced	Negligible	Often prolonged
Reliability of grounding device	Good	Fairly good	Good	Good	—
Cost	Lowest	Moderate	Low	Moderate; low if cost of duplicate supply saved	—

Table 5 contd

## 8 Electrical Connections for NERs

There are two main approaches generally adopted when applying impedance earthing techniques:

- One NER per transformer unit.
- One NER per substation serving one or more transformer unit(s).

Refer to Figure 8.1 (a), (b), (c), (d).

For one NER per transformer unit the maximum 11 kV earth fault current will depend on the number of transformers operated in parallel (since the associated NER's are also effectively connected in parallel).

Where one NER serves all the transformers at the substation, the maximum 11 kV earth fault current is usually independent of the number of transformers and is determined largely by the NER value. In a 33/11 kV substation with one NER connected to a number of transformers it can be shown that for values of NER greater than approximately 3-4 ohms the available earth fault current converges to a constant value for an earth fault close in to the substation independent of the number of transformers in parallel service (Ref. 7).

The following table outlines the merits/demerits of each type of NER connection.

One NER per transformer unit	One NER per substation serving one or more transformer unit(s)
<p>Easier maintenance in that each transformer/resistor can be withdrawn from service as a unit if required.</p> <p>More NERs per substation, hence higher costs.</p> <p>Higher earth fault current levels. Earth fault current varies depending on the number of transformers in parallel.</p>	<p>Requires consideration of switching and isolation switching and isolation arrangements for allowing safe working on units still in service</p> <p>Only one NER per substation, hence lowest cost. Also more suitable where restricted space is a problem.</p> <p>Lower earth fault current levels. Earth Fault Current not dependent on the number of transformers in service. Essentially fixed level of earth fault current.</p>

The choice between the two cases is mainly determined by the choice of NER.

Early applications of neutral resistance involved liquid resistors which require regular routine maintenance. Where these units are associated with non-dual rated transformers, one resistor per transformer has generally been used.

The single resistor per substation alternative has been adopted by power authorities in the UK (and at Christchurch, N.Z. and in Victoria, Australia). Where the NER has a low maintenance requirement and can be switched out of service for brief periods without loss of supply a single NER can be a practical solution.

Associated with NER installation is the requirement for bypassing and isolating, arising from testing and maintenance considerations. The preferred solution is to interlock the NER isolation and bypass switches in such a way as to make it impossible to accidentally disconnect the neutral point from earth.

In Figure 8.2 (a), (b), (c), (d) various arrangements are illustrated for "outdoor" and "indoor" installations. Figures 8.2 (e) and (f), illustrate 'resonant earthing with residual current control' as installed at Darfield 33/11kV substation.

Although NER's will operate for most of their life at or near earth potential, they have to be treated as high voltage devices in terms of insulation rating, testing and maintenance. The connection arrangement chosen must allow for routine servicing or repair of the NER at some future date after commissioning.

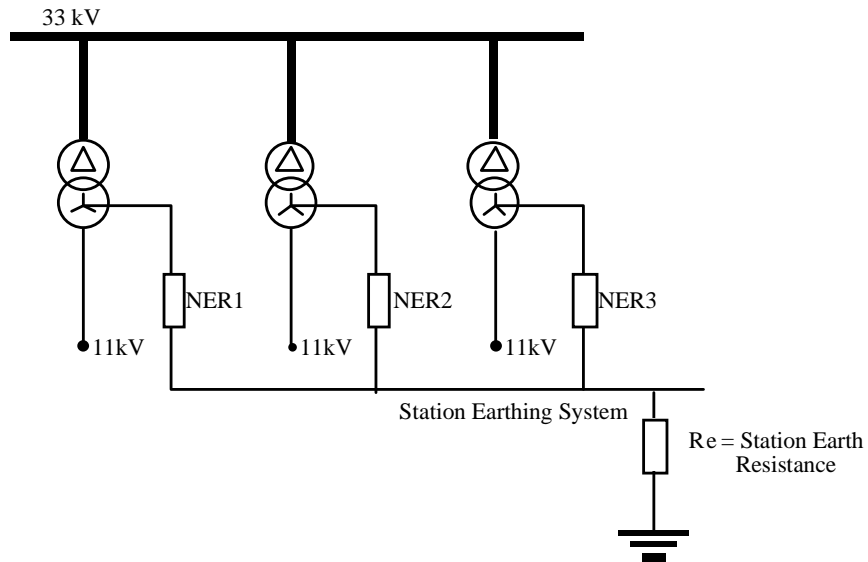

**FIG 8.1 (a) Multiple NER's, One Per Transformer**

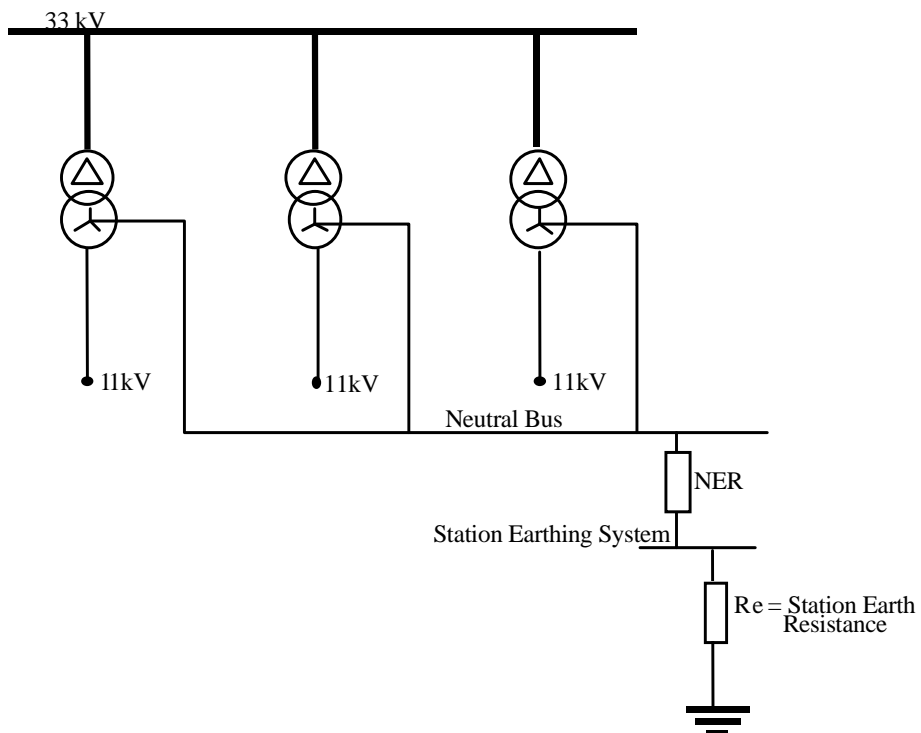

**FIG 8.1 (b) Single NER, One Per Substation**

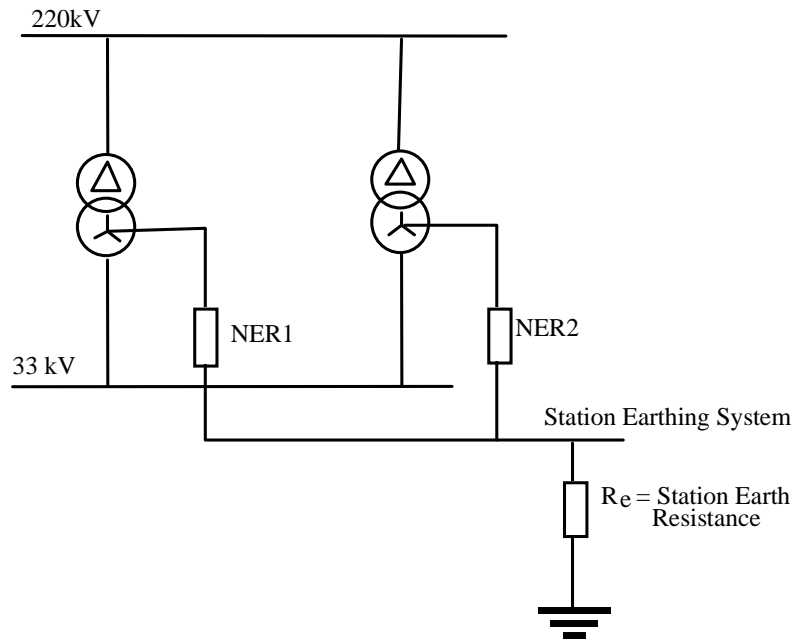

**FIG 8.1 (c) Transpower Bulk Supply Point - Retrofit Example  
One NER Per Transformer**

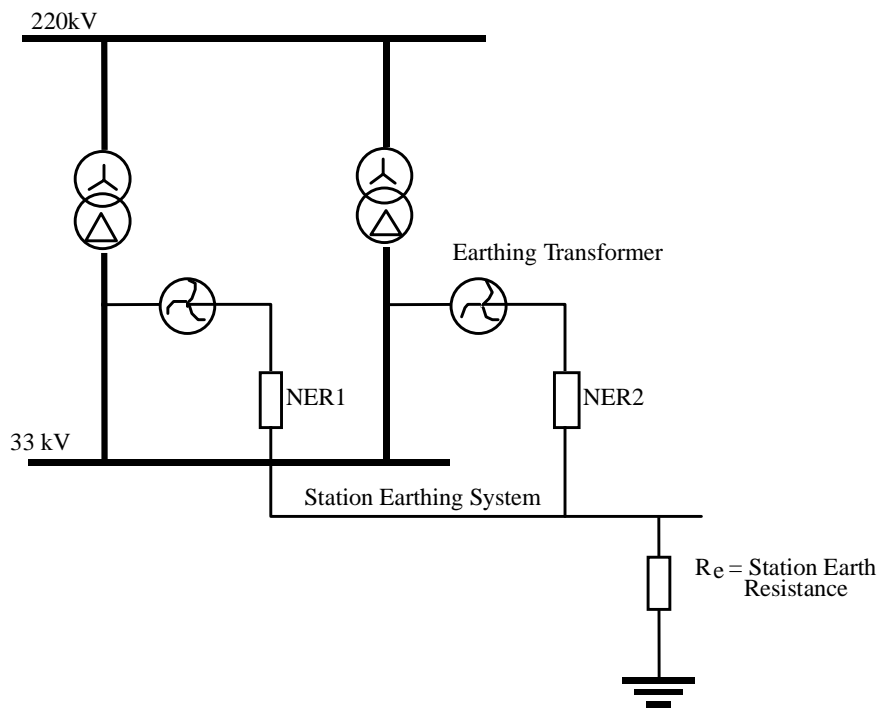

**FIG 8.1 (d) Transpower Bulk Supply Point - New Practice  
One NER Per Earthing Transformer**

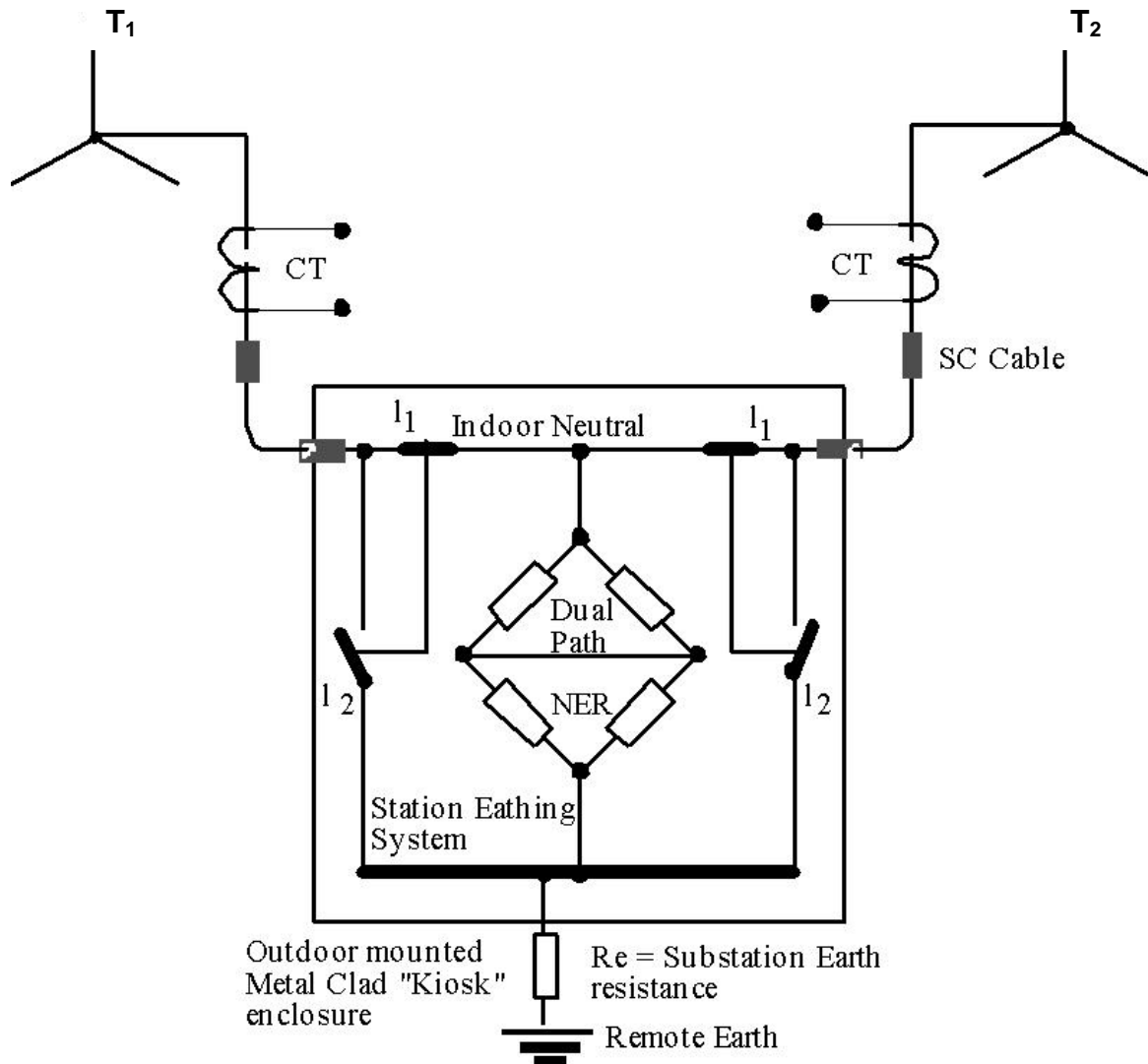

Interlocked Switches to prevent unearthed transformer neutral

$l_1$  = Neutral Resistor Isolator Switch

$l_2$  = NER Bypass Switch

CT = Neutral Protection CT

**FIG 8.2(a)** Arrangement of Switching and Connection for Cable Connected Single NER per Substation - 33/11kV System

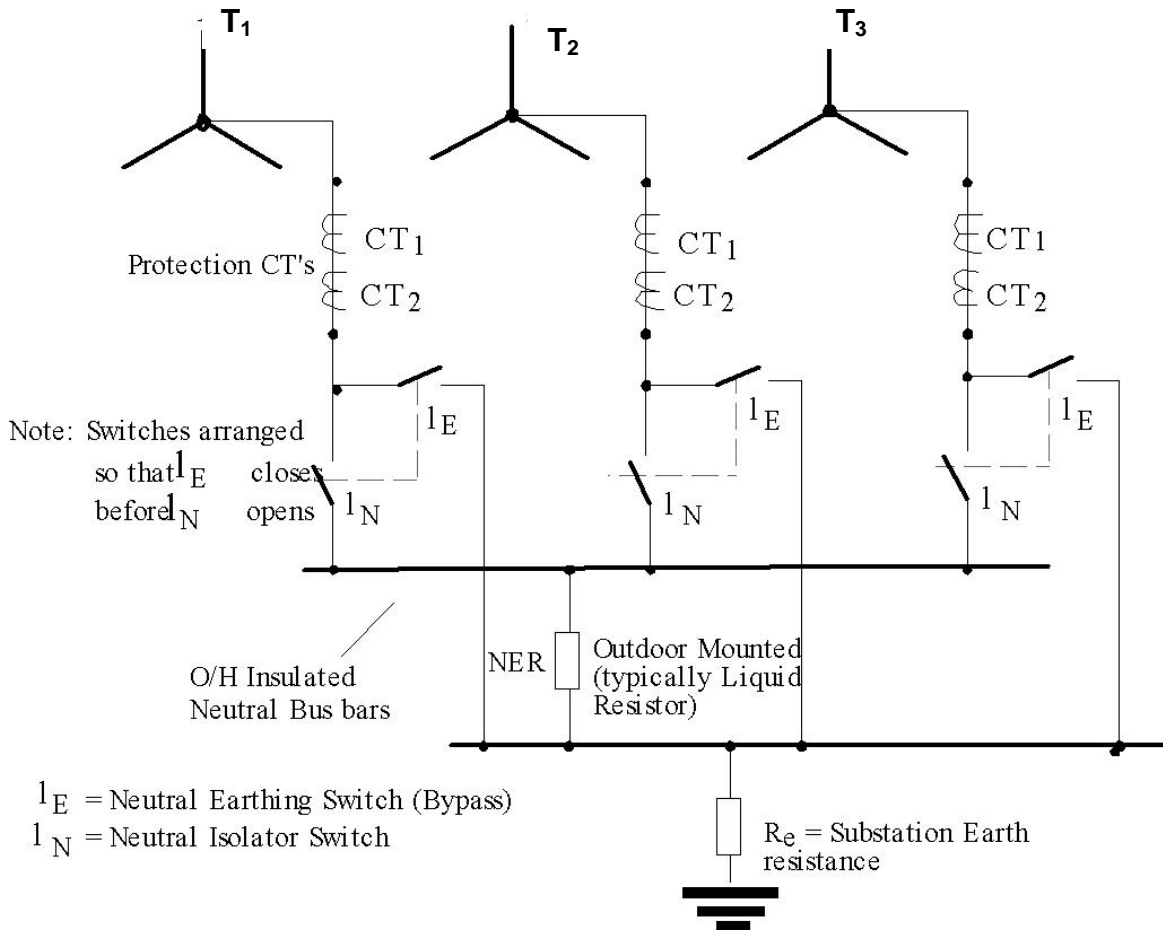

FIG 8.2(b) Arrangement of Outdoor Gear

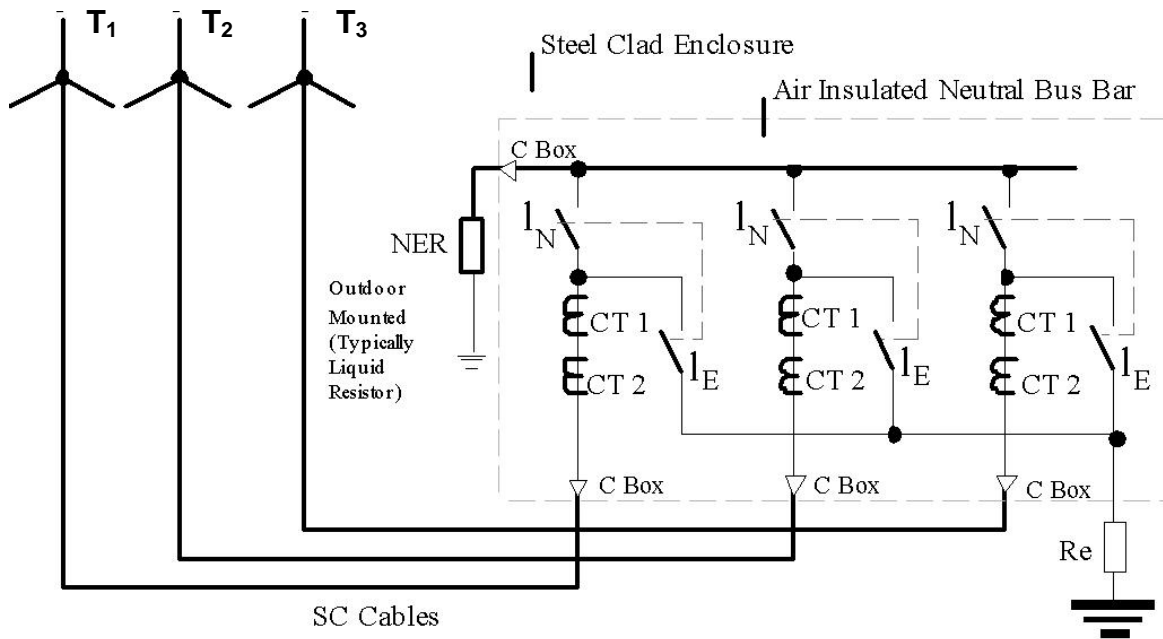
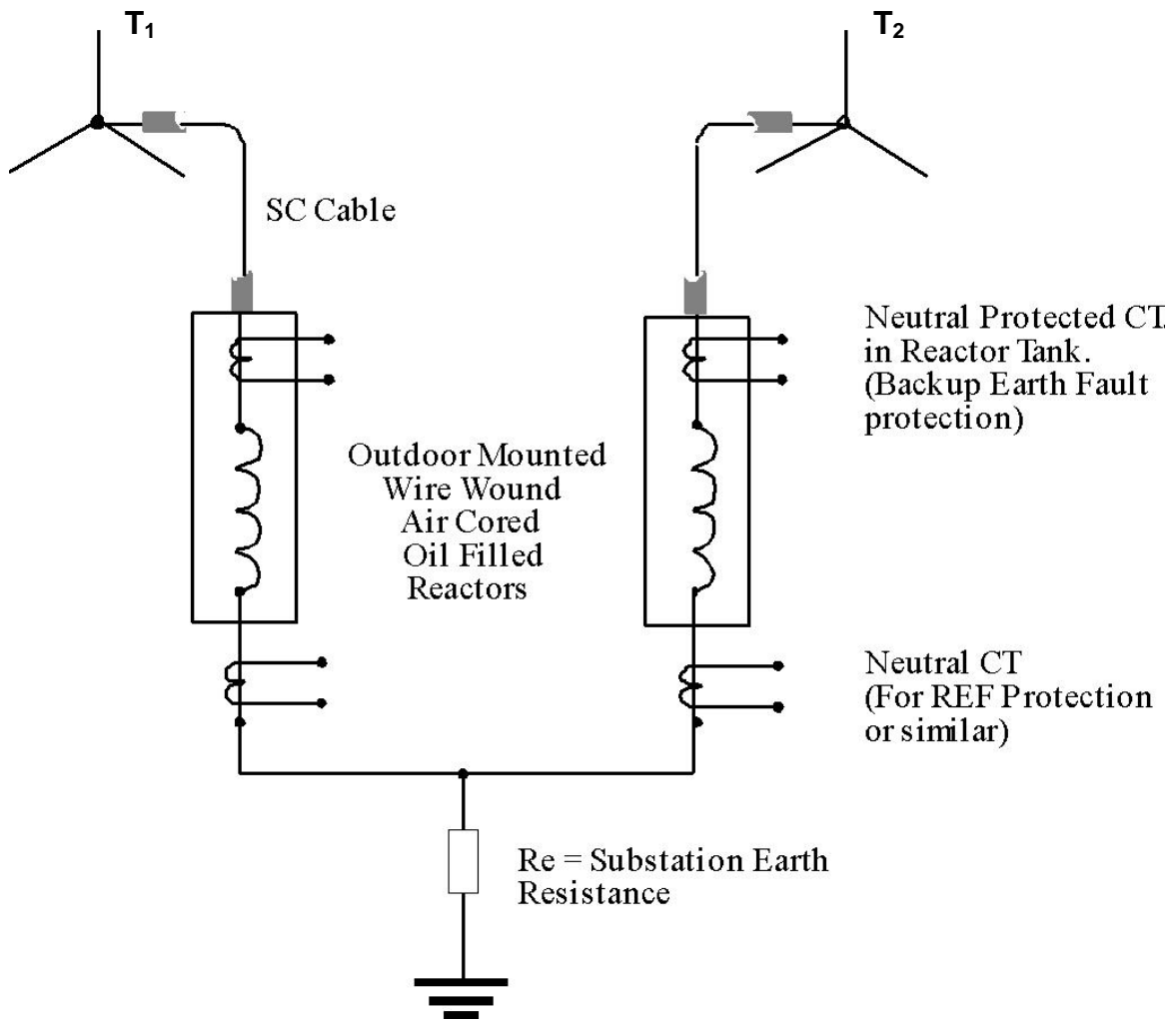

FIG 8.2(c) Arrangement of Indoor Gear

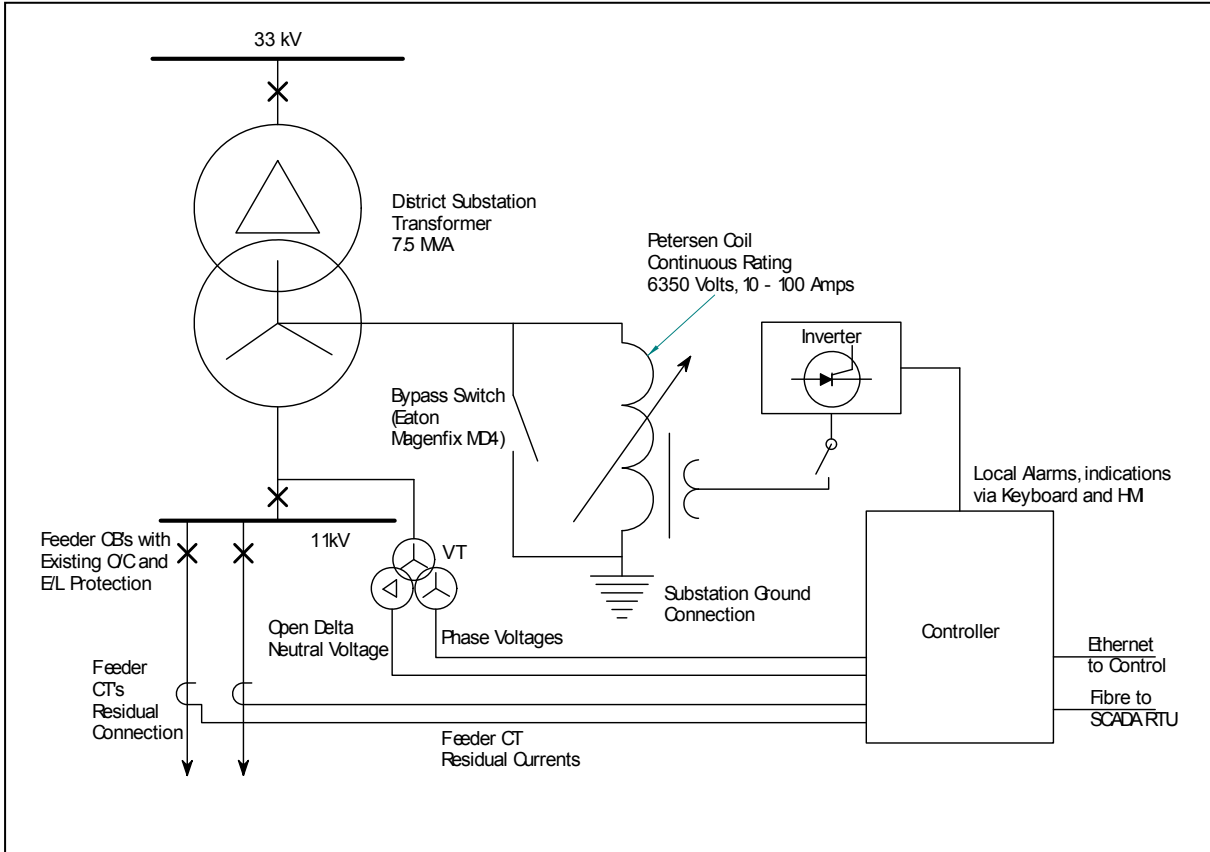



**FIG 8.2(d)** Arrangement of Neutral Earthing Reactors connections and switching for cable connected multi-NER application suitable for dual rated transformers. No bypass or isolation facilities provided.

**Darfield substation  
Petersen coil and RCC system**

**Figure 8.2(e): Schematic diagram**



**Figure 8.2(f): Residual current and voltage connections**

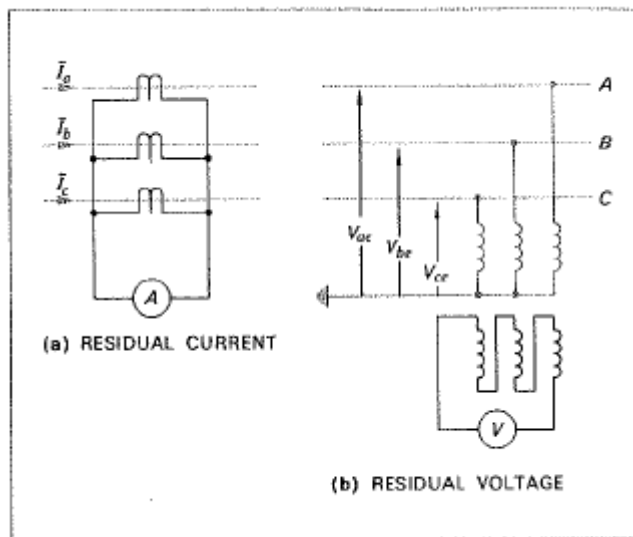

## 9 Installation

Two distinct situations arise depending on whether an NER is being retrofitted to an existing transformer or a new installation is being constructed with impedance earthing provided in the design.

### 9.1 Retrofit of an NER

In the retrofitting case, space limitations may be significant. During a phase to earth fault, the NER and associated connection equipment is subject to voltages up to at least the normal phase to neutral system voltage (e.g. 6350 volts for an 11 kV system).

It follows, therefore, that NER's and connecting equipment should be designed and constructed as normal HV equipment and appropriate clearances should be observed.

In common with other similar equipment, provision should be made for routine or fault disconnection and isolation to enable testing and repair or maintenance activities to proceed safely as illustrated in Figs 6.2 (a), (b), (c), (d).

The neutral/earth connection of an impedance earthed system may be switched, but only where the associated transformer starpoint is connected to earth at all times, either directly or through the neutral earthing impedance. This arrangement has been permitted since the issue of Regulation 84 (6) (b) of the Electricity Regulations 1997.

### 9.2 New Installations incorporating NER's

In a brand new installation space may still be limited and this may influence the type of NER employed.

If liquid resistors are to be used, dependant on climatic conditions, it may be desirable to provide a sheltered environment to reduce standing heating losses. Other types of resistors may benefit from improved air flow to attain a suitable heat dissipation rating.

Regulation 41 of the Electricity (Safety) Regulations 2010 concerning structural loading on works (i.e. strength of works) requires all installations to be designed, constructed and maintained, so as to minimise as far as reasonably possible, the risk of injury to persons or damage to property from the expected (mechanical) loading, having regard to the recognised natural occurrences in the area the installation is to be situated in. Design therefore needs to have regard for earthquake resistance, as well as any other local natural phenomena which may be relevant to the strength of the installation (e.g. wind).

Conductor and busbar ratings should be designed for full fault duty where by-pass switching (direct earthing) is provided.

Connections to the substation earthing system must be adequate in capacity, suitably protected against mechanical damage, and must not be broken (except for testing purposes). These requirements are sound engineering practice.

### 9.3 New Installations incorporating Resonance Earthed Reactors (Peterson Coils)

The first installation in New Zealand of resonant earthing with residual compensation was installed in 2008 at the Darfield 7.5 MVA 33/11 kV substation. This Canterbury substation supplies 1800 customers over 230 km of overhead lines and 15 km of cable.

The Peterson coil was placed alongside the transformer, and connects the transformer neutral to the substation ground. The coil was rated for 100 A to allow for switching and network development, which could lead to a doubling of the line length connected to Darfield Substation, which would double the capacitive leakage current to earth that the Petersen coil needs to compensate for.

The coil itself employs a primary winding of two air cooled coils of 11kV wound onto a two limb laminated steel core with tuning capacitors mounted on top in a stainless steel cabinet. A bypass switch is installed to provide the transformer neutral to earth connection when maintenance is carried out on the Peterson Coil. All the control and protection equipment is installed indoors on two standard 600mm wide panels.

## 10 Commissioning

This main purpose of this phase of installation is to verify the critical components comply with specification or design performance criteria.

NER commissioning test requirements will be governed by the nature and type of device being applied, but in general will involve at least the following:

- **Current rating/temperature rise testing**
- **Voltage withstand of device and associated connection equipment**
- **Resistance/reactance measurement**
- **Associated protection equipment functional testing**
- **Associated auxiliary control/monitoring equipment testing**
- **Mechanical mounting security checking**

**Note:**

Type testing certificates of established NER designs may be acceptable in lieu of on site heavy current and voltage tests.

## 11 Routine Maintenance

Routine “in service” testing is required at all NER installations to confirm the continuing serviceability of the equipment.

The type and frequency will depend on the type of device in service and the nature of the application.

A typical maintenance schedule for a liquid NER is given in Appendix C. The usual routine testing period for these devices is 12 months and is sometimes scheduled along with transformer tap changer maintenance where convenient.

Non-liquid devices (e.g. metallic grid resistors, carbon/ceramic resistors and reactors) can generally be expected to have a longer period between routine inspection and testing.

## 12 General AC Network Benefits of Installing NER's

Although this guide is primarily concerned with the use of NER's to limit fault current between phase and earth, for the purpose of controlling the level of Induction or EPR hazard to telecommunication users, staff and plant, there are other benefits which accrue to the AC power network which should be taken into account whenever a cost/benefit analysis is made.

The immediate benefits for the AC network, from installing NER's include:

- reduced damage at the fault location (refer also 3.2) because the energy dissipated at the fault is proportional to  $I^2t$  (e.g. a fault current reduction to 50% of original value reduces energy at fault location to 25% of original value). Repairs will generally be easier to action and take less time to complete.
- fewer 3 phase faults can be expected. Many 3 phase faults develop or evolve from single phase faults of high energy levels. Three phase faults are often expensive and time consuming to repair.
- circuit breaker maintenance costs are reduced as a result of the reduction in the number of 3 phase faults, and of the reduction in the magnitude of single phase faults.
- fewer voltage depressions occur, and those that do have a smaller magnitude of depression. This results in a reduced impact on customers, i.e. quality of supply is improved.

- personnel hazard voltages, both step and touch potentials, which are determined by single phase fault currents, are also reduced.

The longer term benefits for the AC network include:

- the use of lower cost underground cables for new installations, as a result of being able to use cables with sheaths rated for lower fault current values (refer also 3.2).
- savings in new earth mat costs, i.e. less copper required to remain within step and touch potential hazard limits.

## 13 The use of NERs in Mining and Industrial Applications

### 13.1 General Mining Applications

In mining applications, where electricity is used as the primary source of energy, two major differences exist on the mining site from those found in normal industry.

Firstly, in most instances the surface soil layer has been removed to expose base rock or mineral deposit. In these instances the impedances achievable by normal earthing techniques are grossly unsatisfactory. Therefore effective earthing systems cannot be achieved to operate protective equipment or maintain acceptable potential rise limitations. Yet, it is within these locations that the mining machinery is expected to operate.

Secondly, most mining machinery is fairly mobile either while it is in operation, e.g. bucket wheel excavators, or when it is regularly relocated, e.g. conveyor systems.

These factors produce a situation where the earth point used for most mining equipment is usually remote from the mining equipment and the single phase fault to earth return path usually includes a long length of supply cable.

In such situations a phase fault to earth will usually produce hazardous step and touch potentials and it is therefore necessary to restrict the earth fault current.

The use of high supply voltages, typically 11 kV in New Zealand, and the high energy level available, typically upwards of 100 MVA, further increases the potential dangers.

**Note:**

Overseas, some mining equipment is supplied at 33 kV and draws up to 20-30 MW.

The normal method of controlling this hazard in mining installations is to install an earthing impedance to limit the earth fault current to an acceptable level to protect personnel from both step and touch potentials.

Most items of equipment and all cables are designed to ensure that phase/phase/earth faults cannot easily occur and that any failure results in a phase to earth fault. This approach allows fault energy to be restricted by an NER.

In addition to providing potential rise protection the limitation of fault energy also protects personnel from burns and flashes if cable faults occur while trailing cables are being handled.

Since the neutral is not reticulated, single phase equipment must be supplied by auxiliary transformers arranged to convert phase to phase voltage to the appropriate phase to neutral voltage. In some instances these supplies are also NER earthed at a centre tap.

To provide protection operation in the event of a phase to earth fault, a system of core balance, or NER current operated, earth leakage circuit breakers is employed.

In mining operations the ratio between trip level and NER current is typically 1:10. Some countries set different levels of NER current values ranging from 5 and 20 amps and because most New Zealand equipment has been imported, equipment covering the full range is installed in various locations throughout the country.

The legislation in some countries, and most particularly in Australia on which much of our equipment is designed, sets a 60 volt maximum potential rise requirement as well as a maximum current level of 5-20 amps depending on supply voltage.

Australia, in conjunction with IEC requirements, has set a second requirement that the electrical energy supplied to a mining site cannot cause that site's earthing system to rise in potential with respect to remote earth by more than 60 volts.

This can be achieved in three ways:

- By providing a very low earthing impedance capable of restricting the earth potential rise even for primary supply earth faults.
- By using two earthing systems arranged so that the mine site earth is outside the 60 volt contour of the supply protective earth system.
- By supplying the site from a supply system that itself incorporates a neutral earthing impedance.

These considerations apply equally to open cast and underground supplies.

### 13.2 Underground Mining Sites

In underground mines the use of NER's is even more important in limiting potential flash energy and consequently each transformer circuit, even those within machinery, usually incorporate a NER.

A discriminatory protection system is usually employed to protect distribution networks. This system usually uses both time and current level discrimination to achieve satisfactory operation. In addition a back up trip system derived from the NER current is often installed.

The NER's and earth leakage trip systems at a mining site must be regularly tested and therefore single leg NER's are preferred.

At lower voltages the test circuit directly injects earth current which tests both the NER and the trip circuit. At high voltages (>1000 V) toroid current injection testing is used.

Testing, including actual opening of the supply, is carried out during the regular shutdowns required for mechanical maintenance.

A mining application NER is usually short time rated, relying on circuit breaker operation to prevent overloading.

An additional benefit of NER systems is to limit the damage to equipment such as motors when a fault occurs.

Resistor, inductor and transformer/resistor systems are all used in mining NER systems, although where long cables are installed, resistor systems are used to avoid resonance between the cable capacitance and the reactance of an inductor.

At lower voltages (<1000 V) neutral inductors are preferred because of cost and size considerations.

NER systems in underground mining operations provide a practical way of complying with the Health and Safety in Employment (Mining - Underground) Regulations 1999. In particular, Regulation 45 requires all practicable steps to be taken to ensure the maximum earth fault current is limited to as low a value and as short a duration as is reasonably practicable, in any electrical system operating at 400V or greater, or that is used to supply mobile electrical plant.

Whenever NER's are intended for a mining application, a check should be made at the design stage to ensure that the requirements of Regulations 41 to 49, and 52 to 53, of the Health and Safety in Employment (Mining - Underground) Regulations 1999, will be met.

### 13.3 NER's in other Industries

In addition to mining applications, NER's are useful in two general types of industry.

#### (a) Hazardous Environment

In a hazardous environment they can limit potential rise, thus reducing the possibility of dangerous sparking during a phase to earth fault.

**(b) High Availability Requirements**

Electrical plant which requires a very high availability can be supplied via an NER which will allow ongoing operation in the event of an insulation failure. A failure alarm is also provided.

Both of these features are used in petrochemical plants throughout New Zealand.

These systems also improve the safety of live equipment maintenance and testing procedures as they limit the fault energy that is available in the event of a mistake or slip.

## 14 References

1. IEEE "GREEN BOOK", Recommended Practice for Grounding of Industrial and Commercial Power Systems. IEEE Std 142 - 1982.
2. "ELECTRICAL TRANSMISSION AND DISTRIBUTION REFERENCE BOOK", 4<sup>th</sup> Edition, Westinghouse Electric Corporation, East Pittsburgh PA, 1964 Chapters 14 and 19.
3. "Power System Earthing", D A Winthrop, Lecture Series F1, First NZ Residential School in Power Engineering, University of Canterbury, February 1984.
4. IEEE Guide for Ground-Fault Neutralizers, Grounding of Synchronous Generator Systems, and Neutral Grounding of Transmission Systems. IEEE Std 143 - 1954.
5. IEEE Guide for Determining the Maximum Power Station Ground Potential Rise and Induced Voltage from a Power Fault. IEEE Std 367 - 1979.
6. Neutral Grounding in High Voltage Transmission, R Willheim, M Waters : Elsevier 1956.
7. The Case for Resistance Neutral Earthing of Networks Up to 33kV, J R Anderson, NZ Energy Journal, July 1978.
8. Neutral Earthing Resistors - Why Not? Bryan Leyland and Rhys McDougall - April 1999 (EEA Conference paper - Auckland, June 1999)
9. NZECP35, New Zealand Electrical Code of Practice for Power System Earthing.
10. ESAA Substation Earthing Guide - 2000
11. IEC 71-2; 1996 Insulation Co-ordination Part 2 : Application Guide

## Appendix A

### Time Domain Study of EPR

When an earth fault occurs, the resultant voltage can be divided into three components:

- 1 The steady state post-fault voltage.
- 2 An exponentially decaying off-set voltage.
- 3 A travelling wave which is a transient voltage made up of a wide band of frequency components.

The steady state post-fault voltage is easily calculated.

The exponentially decaying off-set voltage and the transient voltage is usually accounted for by multiplying the steady state post-fault voltage by a factor of 1.2 to 1.5. A time domain simulation program (EMTP) was used to simulate a simplified 11 kV system to show that the use of a multiplying factor is justified.

Figure A1 shows the test system.

It consists of two supply transformers with a common NER. Each supply transformer has four feeders, two overhead lines with a total length of 7 kilometres and two cable feeders with a total length of 11.25 kilometres. The entire feeder load is lumped at the end of the feeder on the assumption that intermediate transformers and their loads are effectively an open circuit to the travelling waves along the lines and cables. The substation earth mat resistance is ignored as it is swamped by the NER.

Table A1 gives the multiplying factors for various test configurations. The fault is applied on the transformer red phase terminal at peak voltage, a condition which gives the peak over-voltages. Note that this is not a conflict with Section 4.3 where faults applied at voltage zero gave the maximum overvoltage when only the exponentially decaying off- set voltage is considered.

The first entry in Table A1 assumes that the total resistance from the fault point to the NER is one ohm. The overvoltage multiplication factors are at the high end of the suggested range. A one ohm fault path resistance is likely to be a realistic lower value for all faults, even for faults within the substation.

The importance of including the fault path resistance is seen in the second entry of Table A 1 where it is set to zero. It is clear that neglecting the fault path resistance leads to unrealistically high multiplication factors.

Other entries in Table A1 show the effects of changing NER values and arrangement, varying the cable zero sequence capacitance from one to three times the positive sequence capacitance (a typical range for cables below 33 kV), and varying the fault application point.

Factors which reduce the EPR multiplication factor are reducing the NER value, increasing the cable zero sequence capacitance and moving the fault point away from the supply transformer. For faults away from the supply transformer, the fault resistance can be neglected. A high NER value can give EPR multiplication factors above 1.5.

When each transformer has its own NER the EPR multiplication factor was again above 1.5 for faults close to the transformer. This is probably due to the fact that there are fewer paths for the energy in the fault transient to be distributed over.

Cable conductor to sheath faults were not simulated because of lack of data. However, this fault condition should not give unexpected over-voltages. Over-voltages are induced onto the healthy phases by neutral point displacement due to fault current in the NER. The effect of the NER on the cable is to reduce the fault current and hence electromagnetic coupling. Compared with faults at the cable terminals, the cable sheath resistance will reduce fault currents for mid cable faults, reducing neutral displacement.

It is important to realise that the model is a simplified approximation. In general, a more detailed analysis will lead to slightly lower over-voltages. One important factor not modelled is frequency dependence of transmission lines and cables which will attenuate the transient voltages responsible for the over-voltage peak. Another factor is the unequal length of the feeders and the presence of spur lines which will spread out the travelling waves.



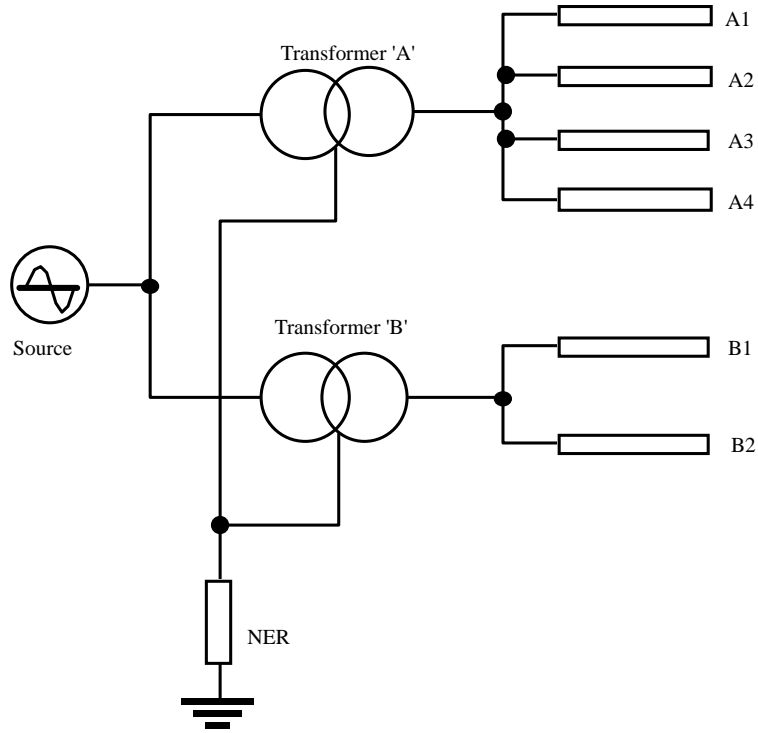

FIG A1

Source	33 kV infinite bus		
Transformers	33 /11 kV D Y		
	Winding impedance referred to the HV phase winding.	$r = 1.4376 \Omega$	$L = 26.1905 \text{ mH}$
Feeders A1, A2	Overhead transmission line, 7 km length		
	Zero sequence	$r = 0.1416 \Omega/\text{km}$ $C = 1.3635 \mu\text{F}/\text{km}$	$L = 0.5264 \text{ mH}/\text{km}$
	Positive sequence	$r = 0.3057 \Omega/\text{km}$ $C = 3.4558 \mu\text{F}/\text{km}$	$L = 0.3879 \text{ mH}/\text{km}$
Feeders A3, A4	Underground Cables, 11.25 km length		
	Zero sequence	$r = 0.1416 \Omega/\text{km}$ $C = 170.51 \mu\text{F}/\text{km}$	$L = 0.5264 \text{ mH}/\text{km}$
	Positive sequence	$r = 0.1416 \Omega/\text{km}$ $C = 170.51 \mu\text{F}/\text{km}$	$L = 0.0833 \text{ mH}/\text{km}$
	For some studies, the cable zero sequence capacitance was increased by three times.		
Feeder B1	Equivalent to A 1 and A2 in parallel.		
Feeder B2	Equivalent to A3 and A4 in parallel.		
Loads $A_n$	Connected in delta, each phase	$r = 153.27 \Omega$	$L = 50.364 \text{ mH}$
Loads $B_n$	Connected in delta, each phase	$r = 76.635 \Omega$	$L = 25.1821 \text{ mH}$

TEST CONDITIONS	LOAD VOLTAGES			TRANSFORMER VOLTAGES							
	A	B	NER	A1	A2	A3	A4	B1	B2		
Transformer Fault NER 22 ohm RF 1 ohm	1.05Y 1.45B	1.01Y 1.39B	1.43	1.22Y 1.49B	----- -----	1.15Y 1.48B	----- -----	1.03Y 1.42B	1.09Y 1.46B		
Transformer Fault NER 22 ohm RF 0 ohm	1.23Y 1.63B	1.25Y 1.57B	1.66	1.30Y 1.69B	----- -----	1.38Y 1.71B	----- -----	1.26Y 1.63B	1.34Y 1.65B		
Transformer Fault NER 22 ohm RF 5 ohm	1.03Y 1.20B	1.01Y 1.21B	1.20	1.13Y 1.27B	----- -----	1.07Y 1.15B	----- -----	1.01Y 1.24B	1.03Y 1.27B		
End of Line Fault NER 22 ohm RF 0 ohm	1.32Y 1.21B	1.34Y 1.21B	1.29	1.19Y 1.08B	1.33Y 1.22B	1.33Y 1.23B	----- -----	1.34Y 1.22B	1.35Y 1.24B		
End of Cable Fault NER 22 ohm RF 0 ohm	1.01Y 1.23B	1.01Y 1.16B	1.19	1.01Y 1.29B	----- -----	1.04Y 1.10B	1.08Y 1.48B	1.01Y 1.19B	1.02Y 1.16B		
Transformer Fault NER 11 ohm RF 1 ohm	1.05Y 1.37B	1.01Y 1.29B	1.33	1.22Y 1.40B	----- -----	1.11Y 1.40B	----- -----	1.01Y 1.31B	1.03Y 1.36B		
Transformer Fault NER 44 ohm RF 1 ohm	1.06Y 1.51B	1.05Y 1.46B	1.51	1.23Y 1.55B	----- -----	1.20Y 1.54B	----- -----	1.10Y 1.50B	1.15Y 1.53B		
Transformer Fault NER 22 ohm RF 1 ohm Cable zero sequence capacitance three times the positive sequence capacitance	1.04Y 1.25B	1.01Y 1.32B	1.20	1.04Y 1.34B	----- -----	1.11Y 1.36B	----- -----	1.01Y 1.34B	1.02Y 1.43B		
Transformer Fault NER 22 ohm RF 1 ohm Each transformer has its own NER	1.03Y 1.28B	----- -----	1.04	1.32Y 1.50B	----- -----	1.26Y 1.62B	----- -----	----- -----	----- -----		

All test conditions apply to a system where the cable zero and positive sequence capacitances are equal and there is one common NER in the substation unless otherwise noted.

Table A 1 EPR MULTIPLICATION FACTORS

## Appendix B

### Investigations into EPR Transient Phenomena

Earth potential rise on multiple earthed neutral systems caused damage to Telecom plant which was not consistent with the calculated EPR levels. A notable example occurred in 1981 at New Zealand Structures in Christchurch, when a 3250 V peak (calculated) EPR caused damage to Telecom cable which was thought to have a breakdown voltage in excess of 8000 V RMS. A search of available literature at the time indicated that under transient conditions, the voltage would not have exceeded 4875 V ( $1.5 \times 3250$ ) in an absolute worst case. It was therefore postulated that a unique phenomena may have occurred which was not covered in the literature.

At the time it was believed that this phenomena might have been caused by a resonance between the large 11 kV lead-in cable zero sequence inductance (associated with armoured cable) and small system capacitance (caused by short aerial 11 kV feeders).

Using typical system C, L and R values, leads to Q values up to about 400 ( $Q = L/RC$ ;  $R = 2$  ohms,  $L = 30$  mH,  $C = 100$  nF).

With these large values of Q (EPR multiplication factor) it was concluded that a short duration (a few hundred micro seconds) transient EPR may have occurred at New Zealand Structures, causing many times the calculated 3250 V peak to be applied to the Telecom cable, thereby damaging it.

The simplistic resonance approximation for an 11 kV network was studied further in 1986/87 using a University of Canterbury computer program for power system network modelling (Transient Converter Simulation Program).

The zero sequence inductance of 11 kV lead-in cable was difficult to define because of the current dependent ferrous material surrounding the cable.

Initially, a value of  $3 \times 30$  mH for 150 m was assumed based on measurements carried out on steel tape armoured Telecom cable. However, the 11 kV cable used at New Zealand Structures was steel wire armoured. Measurements were therefore carried out to establish the effect on the cable zero sequence inductance of the large number of air gaps in the steel wire armouring. It was discovered that the inductance was reduced to  $3 \times 0.3$  mH (from  $3 \times 30$  mH) thereby reducing postulated values of Q to 4.0. Preliminary results (using the above values for L, C and R in the University of Canterbury computer program) indicate that there is no evidence of unusually high EPR multiplication factors, except at unrealistically high frequencies (80th harmonic).

Consideration of the more recent investigations and results lead to the conclusion that in the New Zealand Structures case, there may have been a larger EPR than originally estimated. The earth resistance and calculations were re-checked and it was found that the 3250 V peak was more likely to have been 6500 V peak.

A voltage multiplication of up to 1.5 as suggested in the literature would therefore easily exceed the 8000 V peak breakdown voltage of the cable. There have been no other known cases of EPRs in New Zealand in which multiplication factors in excess of 1.5 may have been present.

It is shown in the example in Appendix A that the transient EPR does not exceed a multiplication factor of 1.5 and that the addition of an NER will reduce both the transient and steady state EPRs.

## Appendix C

### Typical Maintenance Schedule for a Liquid Earthing Resistor

Source : South Eastern Electricity Board (UK)

Maintenance of Outside Plant Specification No 8.3 - Liquid Neutral Earthing Resistors

#### Maintenance Procedure

Item	Operation	Remarks
<b>Note</b>	<b>All work to be carried out in accordance with Electricity Industry Safety Rules</b>	NER to be isolated from all transformer neutrals
1	In those cases where NER is solidly connected, obtain isolation by unbolting the appropriate connections	
2	Inspect incoming connections for tightness and general condition	
3	Clean exterior of unit and remove any rust or loose paint by wire brushing	
4	Check top cable termination where applicable	
5	Examine and clean top bushing, where applicable. Check tightness of connection	
6	Lift inspection cover and inspect tank interior and electrode. If there are signs of corrosion inside, consideration should be given to draining the tank, and patch painting where necessary	
7	Check electrolyte level and if necessary top up level with distilled water	
8	Lower inspection cover	
9	Check NER earth connections for tightness and absence of corrosion	
10	Isolate heater LV supply	
11	Remove heater control cover	
12	Maintain heater contactor	

Item	Operation	Remarks
13	Check heater elements for continuity	
14	Test insulation resistance of heater elements	
15	Check thermostat setting and connections	
16	Temporarily restore LV supply to heater	
17	Check supply and operate thermostat to prove contacts	
18	Check operation of contactor	
19	Isolate LV supply	
20	Replace heater control cover	
21	Restore LV supply	
22	Test value of NER by current injection	See C2 below for 'Test for Resistance'
	NOTE Supervising engineer to compare results with manufacturer's figures and if resistance value is satisfactory, items 23 to 25 inclusive can be omitted.	
23	Lift inspection cover and add setting solution in small quantity to electrolyte.	NB The setting solution is a mixture by weight of pure sodium carbonate and distilled water
24	Agitate thoroughly to mix	Allow 30 minutes before final test to allow for full diffusion
25	Repeat test (item 22) and re-adjust and re-test as required	
26	Close and secure inspection cover	
27	Remake any connections that were disconnected under item 1	
28	Patch paint exterior of unit as required.	(a) Extensive repainting not intended at this stage (b) See notes in Section 1.

## C.2 Test for Resistance

The test must be carried out with the resistor completely isolated from the lead-in and earth circuits. If the supply for testing is taken from between phase and earthed-neutral, ensure that the neutral lead is connected to the earth terminal.

The test procedure is to measure the voltage drop across the resistor with a known AC current of not less than 5 amperes flowing through it.

Since the initial resistance value is based on an ambient temperature of 15°C, it is necessary to measure the temperature of the electrolyte by means of a thermometer suspended through the inspection lid, and establish the correct resistance value for the present ambient temperature from the graph given below. The electrolyte has a negative temperature coefficient, and the curve shows the variation of resistance as a percentage of the initial value given on the rating plate, for any temperature of the electrolyte.

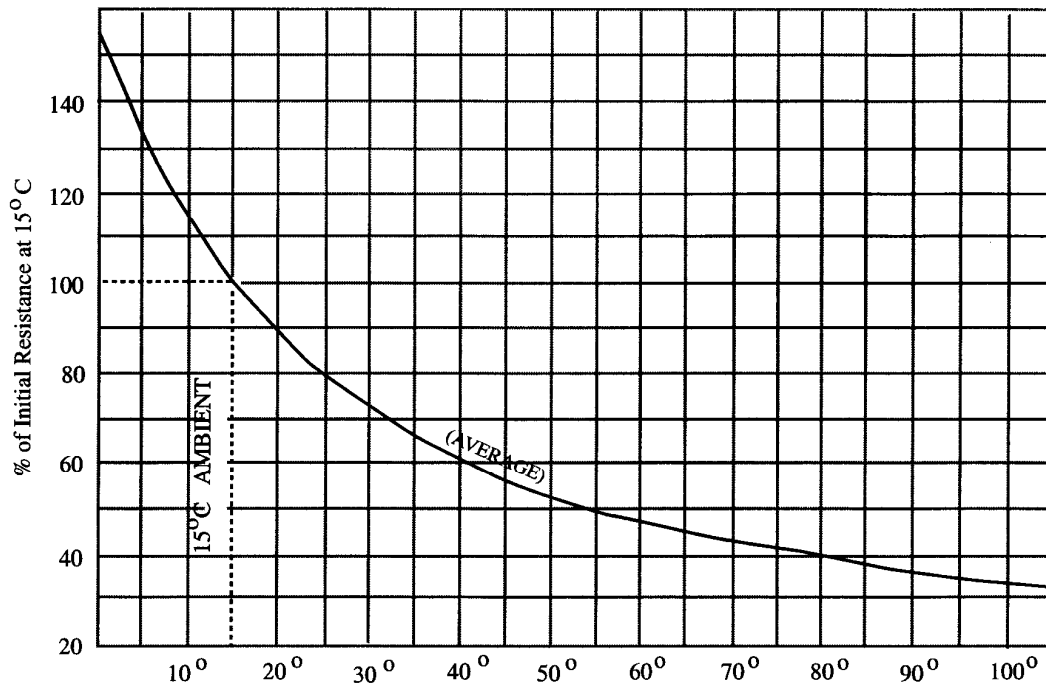

**Fig. C1 - Electrolyte Resistance v Temperature**

It must be appreciated that this curve is an average value and the tolerance limits of +10% should be allowed.

## Appendix D

### Indicative Costs for the Installation of Stainless Steel Resistor NER's

The following figures are indicative costs only, and should not be used for estimating actual project costs. The design and installation details of each project must be determined, and then up to date costs should be sought from manufacturers.

The costs tabulated are given in year 2000 dollars (excluding GST).

#### D1 Cost of Stainless Steel Resistor

The costs below are the total ex NZ factory assembled costs for stainless steel resistors mounted in a protective housing. This includes the cost of the stainless steel resistor elements (typically about 75% of the total resistor cost), supports, protective housing and assembly cost.

<u>System Voltage</u>	<u>Fault Current Rating</u>	<u>Resistance</u>	<u>Cost</u>
11kV	500A for 10 sec	12.7Ω	\$14,000 to \$18,000
11kV	1000A for 10 sec	6.35 Ω	\$15,000 to \$20,000
33kV	500A for 10 sec	38 Ω	\$35,000
33kV	1000A for 10 sec	19 Ω	\$48,000
33kV	350A for 20 sec	50 Ω	\$60,000
33kV	350A for 10 sec	50 Ω	\$46,000
33kV	350A for 6 sec	50 Ω	\$35,000

The indicative costs of the 11kV resistors is given as a range, since the actual cost depends on the cable termination methods, whether a CT is required, and any special mounting and enclosure requirements. These requirements can vary widely amongst Power distribution Companies.

#### D2 Costs of Installing the NER in the Substation

This will depend on the size of the resistor and any special requirements (e.g. seismic), and should be in the range \$7,000 to \$12,000.

#### D3 Comments

It is essential to note that the costs detailed in D.1 and D.2 above are direct costs only.

A major consideration may be the indirect costs associated with any alterations that may be required to existing protection schemes (refer Section 6.2). The direct costs may represent less than half the total costs if it is necessary to change all the feeder protection relays.

Similarly the costs can be increased substantially if the transformer protection scheme requires major modification.

The costs of installation can vary greatly depending on the individual circumstances. In the worst case it could, theoretically, be necessary to purchase additional land to install NER's. Whilst this is unlikely it illustrates the need to consider each case on an individual basis.

The ongoing costs of the various types of NER must also be considered. These are noted in Section 7.4.

**D.4 Photos of a 11kV 500A for 10 Seconds 12.7Ω Stainless Steel NER**



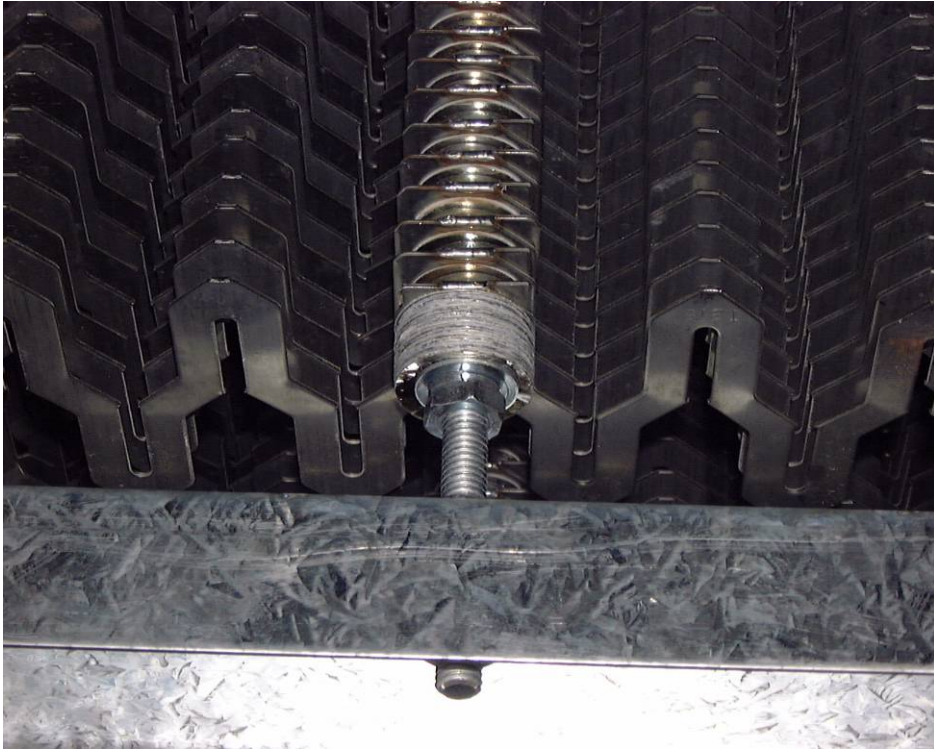

## Appendix E

### Results of a 10 Year Study of Earth Faults on a Combined Urban/Rural 33/11 kV Substation Equipped with NER

Paper presented to the 2000 Electricity Engineers' Association Conference by  
 Stephen Hirsch  
 Performance Engineer  
 Orion New Zealand Ltd.  
 Christchurch, New Zealand  
 hirschs@oriongroup.co.nz

#### History

The results this paper present originate from the solution to a problem being encountered in the Hornby Area west of Christchurch during the period from around 1970 through to 1988. During this period Hornby was changing from a small rural town on the fringes of Christchurch city into a built up urban area.

The problem mentioned above was the increasing number of incidents when serious damage was being caused to Telecom plant during power system earth faults. By 1988 the problem had become so serious that Telecom (or the Post Office as they were known then) were threatening to charge the full cost of repairs to the Power Board. The cost of damage for these incidents had frequently exceeded \$10,000 and they seemed to be happening with monotonous regularity.

The Post Office were also threatening to refuse to allow any new line extensions or connections where it could not be proved that EPR would not exceed 430 volts. For a predominantly rural Power Board in an area where earthing is very difficult at the best of times, this was just about impossible.

These two threats had begun to seriously focus the minds of various engineers on finding a solution.

The rural area – where most of the threats to not approve new extensions were being made, was experiencing virtually no problems. The damage was actually occurring in the urban area of Hornby where distribution was mainly overhead 11 kV.

The problem originated from the fact that when the Hornby area had become built up, the 11 kV distribution system had been reinforced in an ad hoc way to support the increasing load wherever it had appeared. This meant that the original sparse overhead 11 kV system had had additional overhead substations added supplying new sections of MEN low voltage reticulation. These sections of MEN LV were frequently not interconnected with adjacent sections of LV network and most importantly no particular effort had been made to interconnect MEN LV neutrals.

In the 1980's, an increasing number of industrial/commercial customers had also been supplied by dedicated transformers located on site and supplied via short lengths of 11 kV cable Teed off the nearest O/H 11 kV line. Again, no interconnections were generally made with MEN LV neutrals in the street. In some cases there were no nearby MEN systems.

These two practices coupled with very poor earthing conditions resulted in a situation where any 11 kV system fault to earth could easily result in EPR values of 5 to 6 kV appearing on the local MEN. This situation is inevitably fatal for mains powered telecommunications equipment located on customers premises which is thus exposed to the high value of EPR on its power supply and local earth while the Telecom lines coming in from the telephone exchange are effectively at remote earth potential.

Telecommunications equipment manufacturers typically install voltage dependent resistors (VDR's) between the local earth and the telecom lines to prevent excessive voltage differences caused by lightning for instance. The problem is that during an event when excessive EPR appears on the local MEN, the VDR's conduct large amounts of current into the telecom lines, overheat, and usually immolate themselves and everything in their vicinity. The current conducted into the telecom lines can result in major damage to telecom cables and exchange plant, to say nothing of the danger to staff working on exposed equipment.

The situation in Hornby culminated in an incident when a truck loaded with a container backed up in a

street and due to the camber of the road, the top corner of the container crushed an 11 kV cable running down a concrete pole supplying an industrial customer. (Photo 3) The resulting earth fault, which effectively tied a phase directly to the lead sheath of the cable, would have caused an EPR of 4 or 5 kV on the factory MEN system. The factory PABX was destroyed and about \$15,000 damage was done to Telecom plant – damaged cables, blown fuses and damaged exchange equipment. (Photos 1 and 2)

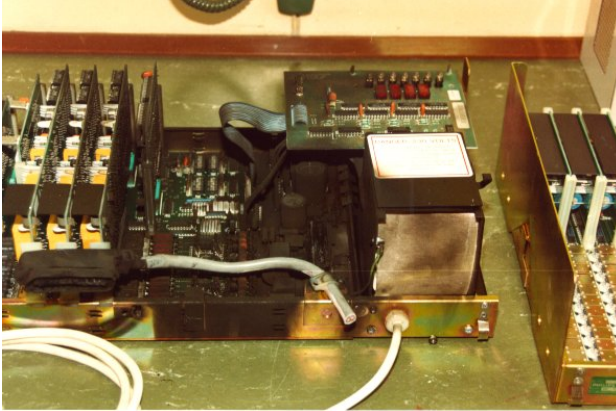

**Photo 1: Damaged PABX**

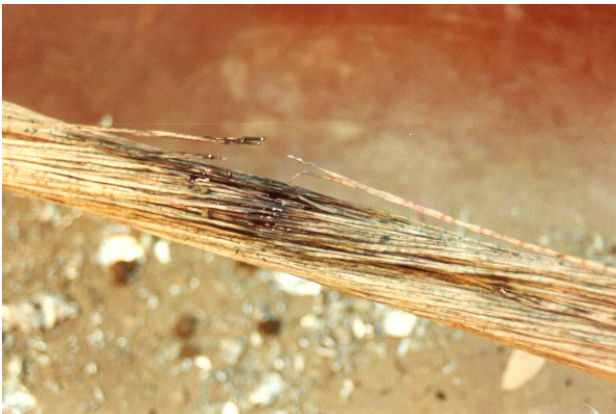

**Photo 2: Damaged Telecom Cable**



**Photo 3: 11 kV Cable on Pole**

Possibly more seriously however, the company used a house in front of the factory for office space. The house power supply was connected to the street reticulation system whose MEN was not interconnected with that of the factory. The company had a paging system, which was controlled from the factory but was powered from the power supply in the house. During this fault, the damage caused to the paging system and other mains powered telecommunications equipment in the house was so severe that the house caught fire and was seriously damaged. Luckily no one was hurt.

### **Proposed Solutions and Concerns**

During the early 1980's various industry working parties had been discussing the problem of excessive EPR and damage to telecom plant. The solution, which immediately springs to mind, improve the earthing, was not a particularly attractive option in the Hornby area. To be effective in reducing EPR, the earth resistance must be over an order of magnitude less than the source impedance of the earth fault current. Previous papers have shown that in an area like Hornby, earth resistances would typically have had to have been lower than 0.1 ohms to keep EPR less than 430 volts. Given the earthing conditions in Hornby and indeed most of the Canterbury Plains this would have been prohibitively expensive and impractical.

One well tried solution to the problem of excessive EPR is to rigorously interconnect MEN's and high voltage cable sheaths/screens to provide a continuous low impedance return path for earth fault

currents. Networks with predominantly underground high voltage networks generally do not suffer from excessive EPR as long as all high voltage cable sheaths/screens are fully fault rated and bonded together.

Unfortunately this was also not an option for Hornby – the costs of tying all the MEN systems together and/or undergrounding the 11 kV network were unacceptably high.

The solution of choice was the installation of neutral earthing resistors (NER's) in the neutrals of 11 kV zone substation transformers. The reasons for this choice have been well covered by a number of previous authors so I will not go into any great detail on this point apart from indicating that the aim of the installation of the NER's is to limit earth fault current, hence EPR and damage to telecom plant.

The Electricity Regulations of the day however did not permit resistance earthing of high voltage distribution systems and a special dispensation would be required from the regulator, who at that time was New Zealand Electricity.

One of the sticking points in the working group discussions was a fear from certain quarters that inserting a resistance in the power system neutral could limit earth fault current to such an extent that power system protection could malfunction and not detect earth faults correctly.

Telecom representatives understandably wanted high values of resistance – 100 to 400 ohms, which would have restricted earth fault currents to the range of 15 to 60 Amps.

Certain NZE representatives wanted values around 10 to 15 ohms so that at least 400 Amps earth fault current could flow. The reasoning for this appeared to be a belief that the NER should not limit earth current to less than normal full load current. So for a typical urban 11 kV feeder with 400 Amp protection CT's, the inviolate rule was that earth fault protection was to be set at 10% or 40 Amps – this gave a nice safety margin of 10.

Of course rural distribution practice in New Zealand is not like this and sensitive earth fault protection is frequently applied down to around an absolute value of 5 Amps independent of the feeder current rating. In the Hornby area, typical urban earth fault protection settings are 10 Amps. Anything higher than this risks uncleared earth faults.

Final approvals for the installation of NER's insisted that the value of resistance be no higher than 20 ohms thus limiting the current to less than 317 Amps for 6.35 kV to earth.

A condition of the approval was that a recorder be installed at a substation equipped with an NER and a record of earth faults be made to determine whether the NER was affecting the performance of the earth fault protection.

### **Chosen Solution**

The chosen solution was a ceramic neutral resistor connected in a bridge arrangement to provide two parallel paths for reliability. A single 20 ohm resistor was installed per substation and the effect on telecom damage was immediate – there were no further serious incidents resulting in any telecom damage. Despite the concern about protection there were no incidents of uncleared earth faults.

Two major undesirable side effects of the installation of the NER's were encountered:

1. During a low impedance earth fault caused by a car crushing an 11 kV cable on a pole, a CT primary in some metal clad 11 kV switchgear located on another feeder supplied by the same substation failed on one of the unfaulted phases thus causing a cross country phase to phase earth fault. This is one of the accepted effects of NER's, during faults unfaulted phases are exposed to full phase to phase voltage to neutral. Given the BIL of 11 kV systems this should not normally be a problem and in this case the CT primary was faulty – the NER and earth fault just uncovered the problem, which was a manufacturing defect.
2. Capacitive residual currents in cable networks supplied by a resistance earthed system can be quite large during earth faults – typically for 11 kV systems, 1.5 Amps per km of cable for a solid earth fault on one phase. This can result in sympathetic operation of definite time earth fault protection on unfaulted feeders, not only at the source substation but possibly also at other locations in the network where extensive cable networks are protected with sensitive earth fault protection. In Hornby at most substations where NER's were fitted this was not a problem because of the limited length of underground cable and slightly higher earth fault pickup settings in the urban area. However at Shands Road, which supplied a number of rural feeders, the earth

fault settings were lower and a number of sympathetic trippings were encountered. To solve this problem the protection relays were set with RI timing curves, which are almost definite time but tip up slightly at lower fault currents thus providing the required discrimination.

A number of other minor protection issues were uncovered but they are not particularly significant.

**Fault Recorder**

The required fault recorder was installed in 1989 at Shands Road Substation, whose single line diagram is shown in Figure 1. This substation is equipped with two 11.5/23 MVA 33/11 kV transformers and supplies a mixed urban and rural area. Of the 8 feeders, 3 supply exclusively rural 11 kV overhead lines while the remaining 5 supply a mix of overhead and underground urban lines. This substation was chosen because of this mix of rural and urban reticulation.

Apart from the two feeders supplying Watties which have higher settings, earth fault protection is set at 8 Amps. The minimum time delay is approximately 1.6 seconds using an RI curve.

The recorder is installed in the earth connection of the NER, Figure 2 and thus monitors the total earth current from both transformers. It is triggered by currents larger than 5 Amps flowing in the neutral connection of the two transformers and records the maximum, minimum and average current and length of time the current exceeds the trigger value.

Given the sensitive trigger value chosen, the recorder is frequently triggered by many events other than real earth faults, some of which are identifiable, i.e. network switching and many others for which no cause can be found. Most of the unidentified ones are low current events that last no more than 1 to 5 cycles.

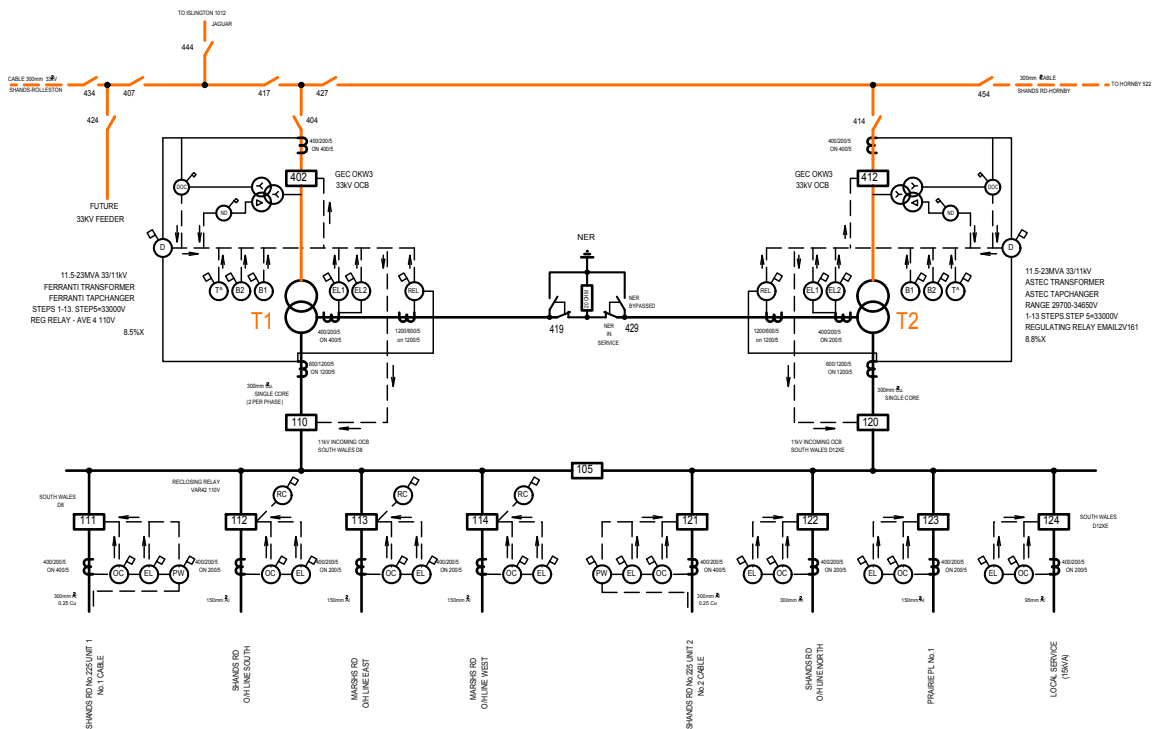

**Figure 1: Shands Road Single Line and Relay Diagram**

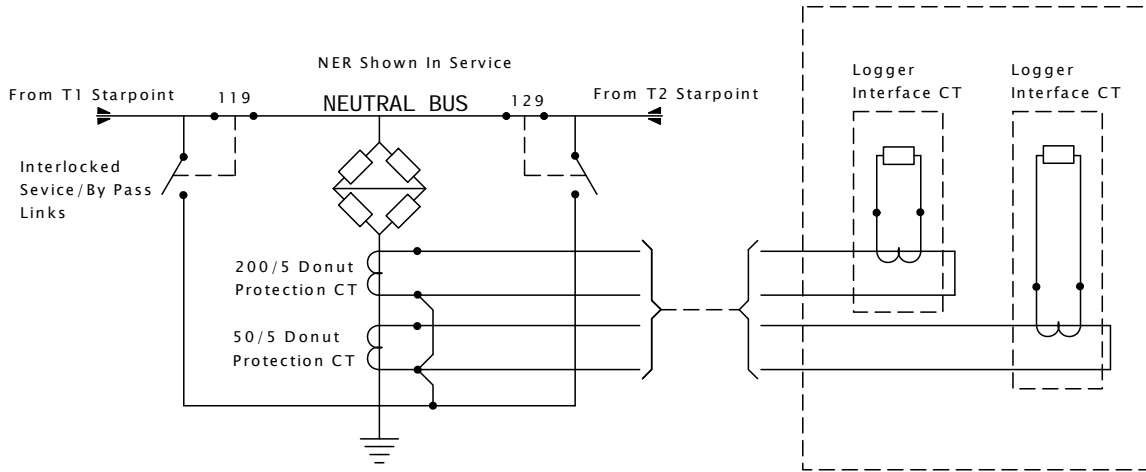
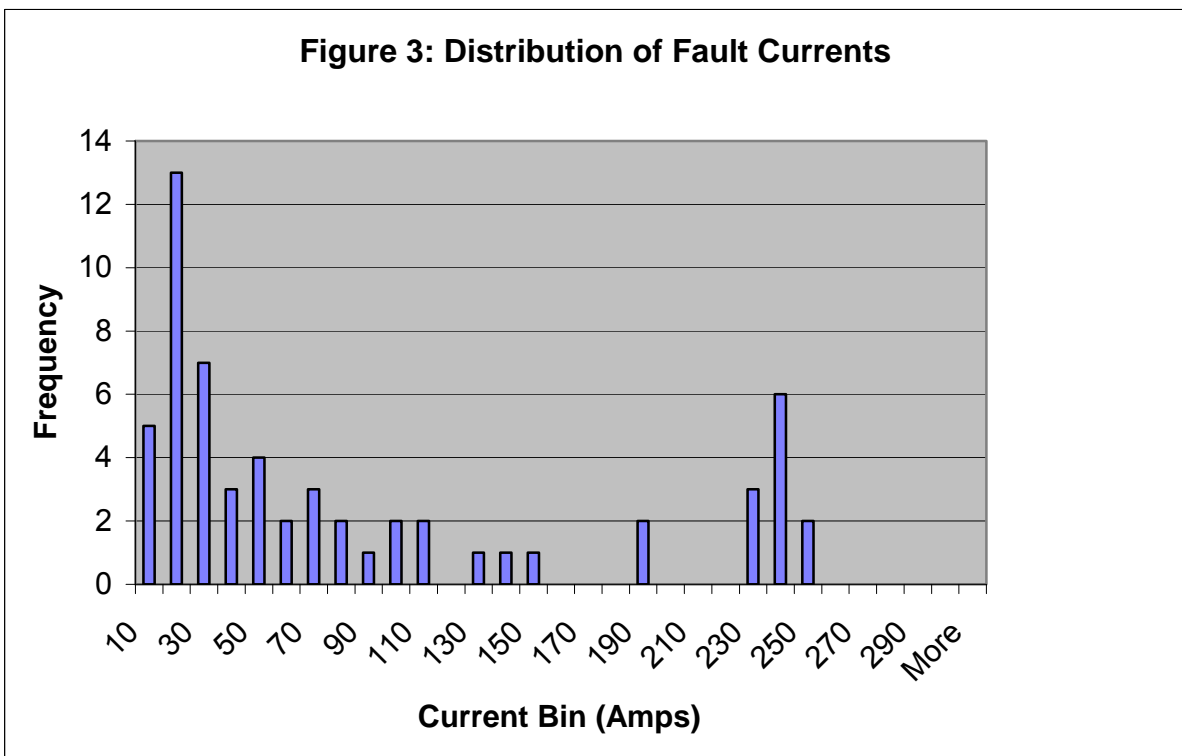

**Figure 2: Connection of Earth Fault Recorder**

**Results**

Over the period from 1989 to 1999, approximately 65 faults have been recorded. Of these, most have been faults on the rural overhead lines and many of these have frequently resulted in a number of reclose operations. There have been a few cable faults in the urban area supplied by the substation and these are clearly visible by their much higher fault currents. Figure 3 shows the distribution of fault currents – two points are immediately apparent – the average earth fault current on the overhead system is approximately 30 Amps while the average fault current on the cable system is around 250 Amps.

Figure 4 shows a plot of clearance time versus fault current. The minimum trip time (approximately 1.6 sec) of the protection can be clearly seen with clearance times increasing for lower currents following the RI curve. For a number of faults, it appears that clearance times are sometimes less than the minimum operating time of the earth fault relay. This is because such faults may in some cases actually be phase to phase to earth faults and may be cleared by phase over-current protection in a shorter time.



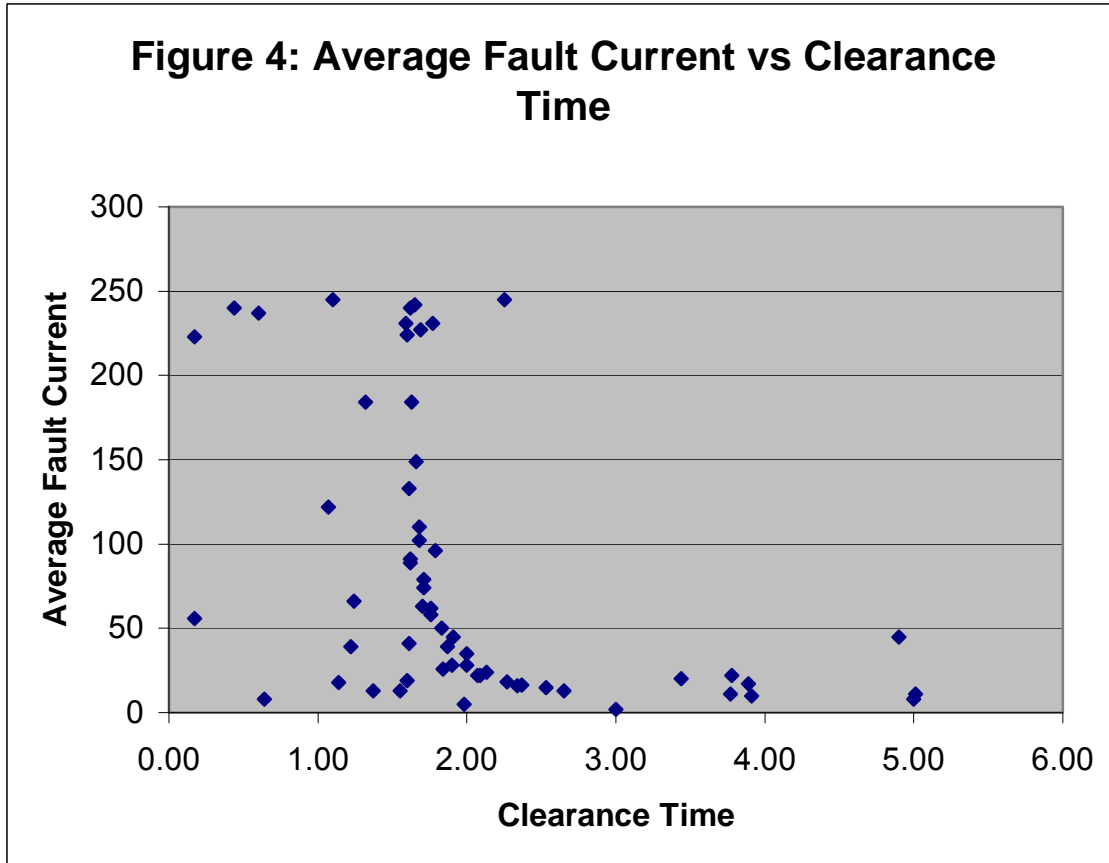

The following points from the fault record are worth noting:

1. There were no uncleared earth faults.
2. Only one fault during the 10 year period resulted in a very slow tripping – longer than 15 seconds. This was traced to a situation where a tractor pulled down a pole and the 11 kV lines fell on a sealed road. It took some 15 to 20 seconds after each reclose to puncture the road seal but the protection did eventually operate even in this case.
3. The fault currents on trips subsequent to reclose operations are usually substantially the same as the first trip. The data shown in the figures has been compiled from first trip currents and has ignored subsequent trips after reclose operations.
4. Given that the majority of overhead system earth faults result in currents less than 30 Amps, the 20 ohm NER has virtually no effect on sensitive earth fault protection because it does not significantly reduce the fault current which is predominantly controlled by the fault resistance.
5. Faults in the cable network result in much higher fault currents, an average of 250 Amps for the small number of faults recorded. In these cases the NER has a significant effect in reducing fault current which might well have been 3 to 5 times higher without the NER. Again the effect on earth fault protection is minimal since the protection is definite time. In some of the cable faults recorded it is apparent that other phases were involved and over-current operation has cleared the fault in a shorter time.

### Conclusions

1. Earth faults on overhead 11 kV feeders in rural Canterbury near Christchurch appear to result in an average fault current of approximately 30 Amps.
2. 20 ohm NER's have virtually no effect on sensitive earth fault protection set at 6 to 10 Amps.
3. With earth fault protection set at 10 Amps, the value of NER could well be increased to 60 ohms with no significant effect on protection.
4. Capacitive residual current can be significant and protection design of sensitive earth fault protection must take this into account.

## Appendix F

### **The first application of resonant earthing with residual compensation to a New Zealand distribution network**

Written by:

Tasman L Scott  
General Manager Network Development  
Orion New Zealand Limited



and

Klaus Winter  
Chief Executive Officer  
Swedish Neutral AB Limited





**CONTENTS****Abstract**

- 1.0 Background**
- 2.0 What is resonant earthing?**
- 3.0 Regulatory compliance.**
- 4.0 Cost / benefit justification.**
- 5.0 Darfield trial installation.**
- 6.0 Conclusions.**

<b>Appendices:</b>	Appendix One	-	Voltage and current vector relationship
		-	Solid versus resonant systems grounded.
	Appendix Two		Darfield substation Petersen coil and RCC system
	Appendix Three		Map of Darfield network area

**References**

**Abstract**

Orion New Zealand operates New Zealand's third largest electricity distribution network, delivering electricity to over 180,000 customer connections in the city of Christchurch and surrounding rural areas, including Banks Peninsula and the Central Canterbury Plains.

Approximately 20,000 customer connections are located in the rapidly growing Selwyn District Council area.

Typical distribution networks in this rural area consist of 3 phase 11kV backbone overhead line feeders mainly along public roads with short spur lines (or cables) supplying individual customer connections.

Spur lines are generally 3 phase to accommodate large water pumping loads supplying irrigation to intensive cropping and dairy farms. Sub-transmission has been typically at 33kV but more recently by 66kV overhead lines.

This form of rural network is typical of New Zealand practice and is subject to single phase to ground "earth" faults due to such causes as vegetation, car versus pole, insulator breakdown and other climatic effects. Earth faults cause approximately 50% of all permanent faults experienced (in the Orion network) and an even higher proportion of transient faults normally cleared by automatic circuit breaker re-closer operation.

Earth faults on the Orion network can produce large earth potential rise ("EPR") voltage gradients at the point of faults which can directly impact on customer installation and cause additional safety concerns by interacting with telecommunication systems.

Present earth fault protection systems cannot detect high impedance faults ( $>1000$  ohms approximately) and some types of earth faults may go undetected which can impose additional public safety concerns due to continued arcing and high EPR at the point of fault.

This paper describes Orion's proposed trial installation at its Darfield substation of an advanced earth fault protection system using a "Petersen" (arc suppression) coil equipped with an additional residual current compensation function. This protection system promises to be much faster and more sensitive than any previous earth fault protection system.

Its application to a specific portion of Orion's network is anticipated to provide a significant improvement in public safety, reliability and power quality, in a very cost-effective manner.

## 1.0 Background

The Orion network services the South Island's largest city (Christchurch) and its surrounding rural hinterland.

Orion's rural network consists of 3250km of 11kV overhead lines, supported by 318km of 33kV and 61km of 66kV overhead sub-transmission circuits and 20 zone substations ranging from 2.5MVA to 10MVA capacity. This distribution network delivers electricity from 2 major and 3 minor grid exit points to approximately 20,000 customer connections through approximately 6,000, 11kV/415V, distribution transformers.

The peak load on this rural network (80MVA) occurs during the summer due to large amounts of irrigation pumping load (40MVA in winter).

The rural region is continuing to develop and customer density is increasing due to the expansion of rural towns such as Rolleston, Lincoln and a proliferation of "lifestyle" blocks.

Intensive dairy farming is replacing traditional sheep farms, cropping and forestry land uses particularly along the northern bank of the Rakaia River.

Urban Christchurch customers enjoy one of the most reliable delivery service levels in New Zealand with a SAIFI of 0.4 and SAIDI of 20 minutes. This is achieved with a largely underground 11kV cable network with both primary and secondary networks providing a highly inter-connectable system.

The rural network previously referred to above however is considerably less reliable with typical figures of SAIFI = 3, and SAIDI = 200 – 300 mins due to the exposed nature of the overhead 66, 33 and 11kV high voltage network employed. The proportion of cable in network is still relatively low, but steadily increasing as townships are extended and lifestyle subdivisions are developed.

Figure 1: Rural/urban SAIDI curves

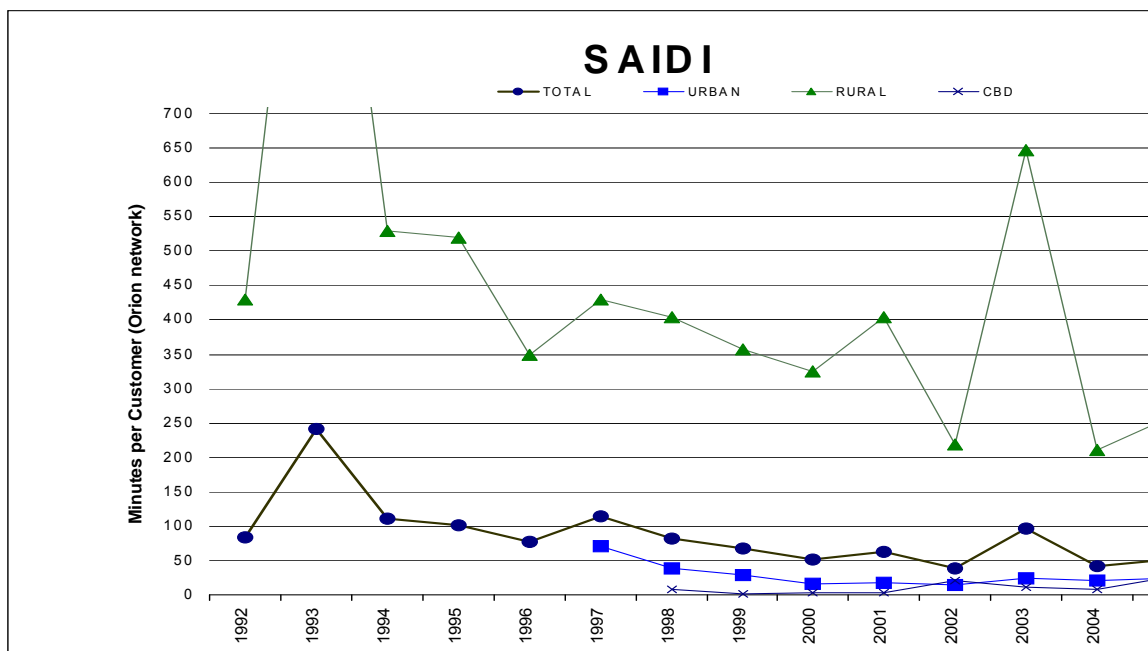

Customers now living in this rural environment represent a large cross-section of society from farm workers, researchers, scientist, students, academics, professionals, small and medium business owners, etc. Their expectation regarding the reliability quality and safety of their electricity delivering service is that it will be similar to a major city where they recently resided before moving to the country.

Orion's rural network performs similarly to most other rural overhead line New Zealand distribution systems and the cause of interruptions is as might be expected due to well known causes such as interference from vegetation, animals and bird-life, insulator pollution and deterioration, third party damage such as motorists hitting poles, and extreme weather conditions such as wind, rain and snow.

In practice our fault records show that about 50% of all "permanent" faults experienced on the Orion network are of the "single phase" to earth type. Permanent faults are the ones that are unable to be cleared by auto-recloser circuit breaker operation.

There is also a class of 'transient' earth faults which are in fact successfully cleared by auto-recloser operation on the Orion network and the analysis of available records indicates that a high percentage (70%+) of such faults are also the single phase to earth type.

These transient faults cause short-term "momentary interruptions" to customer supply which are not currently incorporated into disclosed reliability statistics (in New Zealand).

However the resulting voltage dips and short breaks in supply are noticed by customers and their electrical equipment can be adversely effected. Such effects can include pumping (motor) load to drop out, electronic control computer and electrical appliance operation to be upset and in general a considerable degree of inconvenience to customers to arise.

Earth faults also have a number of other undesirable impacts on customer supply in rural areas, i.e:

- (a) Earth fault currents return to the source transformer neutral through a fault impedance and the point of insulation failure – often causing arcing and hazardous earth potential gradients.
- (b) Arcing can cause ignition of vegetation and lead to fires being initiated at the point of fault. In the Orion network the relatively high soil resistivity can limit fault current and prevent conventional earth leakage protection from successfully operating. Wooden cross-arms also suffer fire damage due to leakage currents to earth below the protection limit settings.
- (c) Transferred earth potential risk (EPR) can appear on a rural customer's MEN earthing system as the HV earth system at each pole transformer also provides the LV MEN source earthing. Several thousands of voltage (up to 6,350V) can be impressed on a customer's neutral / earth system by this arrangement. Damage to mains powered telecommunication devices such as portable phones faxes, computer modems and other mains connected telecommunication equipment is reported as common as fault current seeks to return via the general mass of earth through connections made by telecommunication system to a "remote" earth.

In practice Orion's rural network reliability, delivery quality and safety are all significantly affected by the occurrence of earth faults (and to a somewhat lesser extent short circuit faults).

Conventional improvement initiatives include improved vegetation control, better condition monitoring of insulators, use of covered conductors, and the introduction of additional line circuit breakers, shortening up feeder lengths and the separation of HV and LV earthing systems. All offers benefits, but usually incur considerable extra costs, especially the case of undergrounding the entire network.

Orion has ranked a number of such improvement initiatives in its asset management plan and a summary is present in the table below:

**Figure 2: Ranking of reliability initiatives**

Reliability improvement initiative	Cost per kWh
Resonant earthed system	\$10.5
Line circuit breakers	\$14 - \$30
Tree trimming	\$15 - \$30
Shorten feeder lengths	\$25
Covered conductor (80% of network)	\$78
Underground (80% of network)	\$695
Selective covered conductor for trees	Unknown
These costs to be compared with the cost of unsupplied energy to rural consumers of \$15 per kWh	

**Note:** In this table the cost per kWh for resonant earthed systems was based on pre-contract cost estimates and uses reliability performance figures averaged for all of Orion's rural customers and assumes that 20% of all permanent faults are eliminated. Refer Orion AMP on [www.oriongroup.co.nz](http://www.oriongroup.co.nz)

Against this backdrop of increasing customer dependence on a high quality reliable electricity delivery service Orion decided in the early part of 2006 to carry out a trial of the so called "resonant earthing technique" on part of its existing 11kV overhead rural network.

## 2.0 What is resonant earthing?

The technique of earthing the neutral starpoint of zone transformer secondary windings is common practice in many Northern European, Scandinavian countries and also China.

In New Zealand and Australia both direct (solid) earthing and neutral resistor earthing are commonly employed.

In the UK resonant earthing, resistor and reactor earthing, along with "direct" (solid) earthing all exist today.

The technique of resonant earthing appears recently to be gaining more widespread application across Europe – see reference one. The technique of resonant earthing is described more fully in reference two and basically consists of inserting a tuned reactance between the starpoint (neutral connection) of the secondary windings of zone transformers and ground.

This inductance, more commonly referred to as a "Petersen" or "arc suppression" coil is designed to resonate with the line to ground capacitance of two phases of the downstream distribution network.

This creates, under single phase earth fault conditions, a relatively high impedance path between the transformer neutral point and the ground and very little current flows in this connection and therefore through the "zero sequence" circuit to the point of fault on the network.

The vector phase relationships for single phase earth faulted networks with solid, isolated and Petersen coil earthed source neutrals is shown in Appendix One.

A standard "Petersen coil" does not exactly compensate the entire earth fault current in a network due to the presence of resistive losses in the lines and the coil. However it is possible to compensate further for this "residual" or remaining fault current by injecting an additional 180° out of phase current into the neutral via the Petersen coil; thus effectively reducing remaining residual fault current to practically zero. See reference 2. This paper describes how the technique of residual current compensation (RCC) provides a greatly enhanced performance from a resonant earthed system particularly in its ability to prevent cable earth faults from re-striking and its fast speed of response and ease of faulty feeder detection.

Petersen coils have evolved considerably since their invention by Professor Petersen in 1916 and typically are now designed to automatically tune themselves as the network length varies due to operational switching, etc.

Normal phase to phase voltage relationships in a resonant earthed system remain the same when earth faults occur and as all our customer loads are connected phase to phase on the HV side of distribution transformers their low voltage supply is unchanged when an earth fault is present on the high voltage side.

Therefore it is practicable to continue to supply customer load in the presence of a “permanent” earth fault with no apparent need to interrupt supply as with conventional solidly earthed systems.

Similarly “transient” earth faults merely end up temporarily displacing the neutral voltage with respect to ground whilst leaving the line to line voltages unaffected.

It is therefore not necessary to interrupt the supply to customers for either a permanent or transient earth fault.

The voltage at the point of fault becomes rapidly reduced to a very low level, fault arcing is extinguished, and transferred EPR is greatly reduced.

The “sound” or unfaulted phases of a resonant earth system experience a voltage rise with respect to ground until the single phase to earth fault is removed. This will provide more stress on insulation which could potentially find weak spots in existing network components. 11kV systems normally designed with a 95kV BIL (basic insulation level) which should generally provide a significant margin to handle voltage to ground increases from 6,350 volts to 11,000 volts. All Orion 66 and 33 / 11kV zone transformers have fully insulated secondary (11kV) windings.

Lightning arrestors with an operating voltage specification of 9 or 10kV will not be suitable for 11kV resonant earthed systems. A 12kV operating voltage standard has been chosen by Orion when it first employed neutral earthing resistors in 1987.

Orion also currently employs an ultra violet corona detection camera to survey the pin insulators on its 11kV distribution system. This technique identifies already weakened insulation before permanent faults develop. We hope to have identified and replaced such potentially weak insulators ahead of the introduction of our resonant earthed system in the Darfield area.

### **3.0 Regulatory compliance**

In New Zealand the requirements for protection against fault currents is reasonably prescriptive and is covered by the provision of the Electricity Regulations, clause 62.

In particular clause 62(2) states “Short circuit and earth fault protective fittings must operate to disconnect supply from the circuit or other fittings that they protect, and, clause 62(5) stated “High voltage conductors of overhead electric lines must have earth fault protection fittings that interrupt fault currents to earth in 4 seconds or less.”

The clear implication of the current regulations in respect to earth faults is that they must be disconnected within a prescribed timeframe to make the situation safe for the consumer and the public.

Resonant earthed systems as described earlier meet the safety objectives of earth fault protection in a different way by effectively neutralising rapidly developing earth fault situation without “disconnecting the supply”.

The overall performance objective of ESR 62(5) is still able to be met albeit in a different manner to that anticipated by the Regulation which are based on a conventional solidly earthed neutral system.

Orion has applied for and has been granted an exemption from the above regulations and this will permit the resonant earth system to be operated on the basis that:

- (1) Earth fault current will be initially restricted to a level of between 2-5 amps.
- (2) Residual current compensation will be activated to reduce earth fault currents practically zero and voltage to ground on the faulted phase also to zero within 250millisecs of the occurrence of the fault.
- (3) Fault location will be commenced as soon as practicable after the occurrence of an earth fault and the existing earth fault protection will remain in place as backup to the resonant earthing and residual earth fault current compensation (RCC).
- (4) The resonant earthing and RCC control system will be connected to the Orion SCADA system and provide for continuous monitoring and detection of faults.

In practice Orion has left existing protection systems in place at Darfield, but has decreased the sensitivity of the earth fault protection relay settings from a primary trip level of 6 amps up to 15 amps. This was carried out to eliminate spurious trippings on non-faulted feeders due to increased unbalance capacitive current flows in the resonant earthed network.

Over-current (short circuit) protection settings have been left untouched.

Orion is confident that leaving single phase earth faults on the system will not decrease the safety to the public or the customers connected and that fault location can proceed without interruption to supply.

The equipment to be installed at Darfield provides remote indication in Orion's control centre of a particular feeder earth fault and if a "loop" can be made out in the field a "distance to fault" measurement is possible. Faults on spur lines can be flagged by special pole mounted fault passage indicators mounted at strategic locations in the network.

Fault locating on a resonant earthed network will be a whole new experience for our staff and contractors and we expect to have to learn a few new techniques.

#### **4.0 Cost / benefit justification**

As with any significant (capital or maintenance) expenditure proposed for network performance improvement, it is necessary having identified significant potential benefits – to then identify all costs associated with the application and then compare those costs and benefits to assist with the decision-making process.

Based on budgeted pre contract equipment cost estimates the Darfield trial was anticipated to be about \$200,000, which will allow for equipment purchase, shipping and delivery, installation, commissioning and testing on site at Darfield, plus the introduction of additional 15 special fault passage indicators and two "5th harmonic" pathfinder portable fault locators. As this is our very first trial we are expecting this initial installation to have somewhat higher one-off establishment costs. There is also a component of indirect costs associated with the introduction of any new system / process such as staff training, SCADA interfacing (software functionality). Actual costs will in general depend on network size and the associated "make ready costs"

The benefits of the resonant earthed system can be quantified by applying the "value of lost load" or "unserved energy" to the reduction obtained in interruptions and resulting lowering of "customer minutes lost". This approach assesses the value of the reliability improvements to the customer.

A summary of the cost /benefit results for the Darfield area project are:

Total assessed annual cost	=	32 \$k / yr / substation
Total assessed annual benefits	=	50 \$k / yr / substation

Project benefit / cost ratio is  $\frac{50}{32} = 1.56$

In the case of the Darfield substation which supplies 1,800 customer connections, the annual cost per consumer amounts to  $\$32,000 / 1,800 = \$18 / \text{customer} / \text{year}$ .

In practical terms the customer is likely to experience at least a 20% reliability improvement (in reduced long-term interruptions), a marked improvement in momentary interruptions and a safer overall supply due to reduced EPR transfer to electrical installations and a reduction in arcing at the point of fault (which in turn relates to a reduction) in fire hazard.

The benefits in terms of public safety discussed above are more difficult to quantify, but it is known that alternatives to mitigate the risk of EPR damage alone to customer equipment can be relatively costly; i.e. in the order of \$1K – 3K, per customer installation supplied by an isolated single transformer with “MEN” earthing system. Orion has about 3,000 such systems in service with the number still growing and the implied costs of safety mitigation (e.g. by isolating telecom circuits or by separating out all LV earths from HV earths) is therefore in the range of \$3M - \$9M.

## 5.0 Darfield trial installation

The Darfield zone substation supplies a typical cross-section of Orion’s rural connections – rural township, dwellers, farmers, lifestyle blocks and small industrial / commercial business operations. See Appendix Three for a location map.

It is typical of conditions of the Canterbury Plains with high soil resistivity leading to high earth resistance levels for earthing electrodes.

The substation is equipped with a 7.5MVA 33/11kV TCOL power transformer with five outgoing 11kV feeders supplying 1,800 customer connections over 230km of (largely) overhead 11kV lines. The amount of cable connected amounts to 15 km.

The resonant earthing system with its associated residual current compensation equipment is readily installed at the existing site. The Petersen coil is placed alongside the transformer and connects the transformer neutral starpoint to the substation ground.

The RCC control equipment is located inside the existing substation control building and consists of two standard width (600m) panels.

The schematic arrangement is shown on figure 3, Appendix Two.

The 50HZ inverter associated with the RCC system requires a 50kVA 3Ø power supply from a local service supply.

The existing feeder OCB protection systems have been retained so that over current short circuit faults can still be cleared and the substation can revert back to solid earthing mode if necessary via a bypass switch connected across the Petersen coil.

Short circuit over current faults will continue to be cleared by the existing conventional protection system.

The existing “3 limbed” voltage transformer (VT) at Darfield substation was not suitable for direct use with the RCC system because it did not transform zero sequence voltages and required substitution with a version with three single phase epoxy encapsulated VT’s mounted in the original VT tank. These VT’s are then connected in neutral “open delta” manner to provide a measurement of residual voltage.

The Petersen coil rating was determined by considering the amount of phase to ground capacitive charging current likely to be generated by the two phases of the 230 km of overhead 11kV line and 15 km of 11kV cable associated normally with the Darfield zone substation. This was estimated to be 30 amps for the above system length. The final coil choice made was for a 100 amp rating (at



6350 volts) to allow for system switching which could (practically) lead to a doubling of line length to be compensated, plus an additional margin to allow for increasing amounts of cable to be added over time to the network.

The larger the line length the greater is the capacitive reactance required to be compensated by the inductance of the Peterson coil. As coil inductance decreases, the amount of coil compensation current increases and the coil has to be increased in physical size to handle the additional current rating.

The Darfield coil has a 10:1 tuning ability and this is achieved by switching in capacitors in parallel with the inductance of the coil. These capacitors are connected at a relatively low voltage via a secondary winding providing by the screen conductor of a conventional 11kV XLPE single core power cable. The 50Hz residual current compensation inverter is also connected via a similar secondary winding on the Petersen coil.

The coil itself employs, as stated above, a primary winding consisting of two coils of 11kV single core cable around onto a two limb laminated steel core with the tuning capacitors mounted on top in a stainless steel cabinet. The core is in this case not contained in an oil tank as is the case for earlier Petersen coil designs.

We are expecting this to be a low maintenance long life design.

The indoor mounted control panel provides local indication of line voltages and faulty feeder and enables local control of the system neutral voltage. Remote interfacing is provided via Orion's existing Foxboro SCADA remote and an additional Ethernet communication channel to the Orion control centre in Christchurch.

As part of the trial, we have also installed BMI-Dranetz, a power quality recorder (model ENCORE 6100) at Darfield substation to enable long-term monitoring and make meaningful comparisons with other similar networks (without compensation) and to also allow detailed comparisons to be made with the historical performance of the existing Darfield substation feeders.

Reference was made in Section 3 of this paper of the installation of pole mounted fault locators designed for transient operation in a compensated network. The devices installed are of the Nortrol Linetroll 3500 type which is expected to provide an indication to field operators of the passage transient fault current beyond each fault locator. A total of 15 of these devices are located at strategic points along each feeder and combined with the in built "distance to fault" function of the RCC, should provide clear fault location information on which to base line patrol priority.

The RCC system employed at Darfield is designed to reduce 50Hz zero sequence (earth fault) current to a very low level by the injection of an anti-phase current provided by a 50Hz inverter. It has been observed over many years that harmonic currents, particularly the 5th harmonic (250Hz) can be accentuated in a faulty feeder on a resonant earthed system. This phenomenon has been used as the basis for field fault location in the UK using handheld 5th harmonic detectors and will be further explored during the Darfield trial.

## **6.0 Conclusions**

The Darfield trial of resonant earthing with enhanced residual current compensation is a first for New Zealand and probably the Southern Hemisphere.

Orion is expecting to achieve improved performance from its typical rural distribution network in the areas of:

- Power quality.
- Reliability.
- Public safety.

The management of single phase earth faults and their effects have always provided a challenge for the company with solid (direct) grounded neutrals and high resistivity soils.

Increasing customer expectations in terms of power quality and reliability are becoming harder to meet cost effectively with conventional network designs and operational practices.

Safety regulations relating to power system earthing are currently under review in New Zealand and the adoption of more stringent “step and touch” voltage compliance criteria could prove costly to achieve using conventional solidly earthed systems.

Orion has employed neutral earthing resistors (20  $\Omega$ ) on its 11kV networks in the past to assist in mitigating some of these safety issues.

The introduction of resonant earthing is seen to be a logical extension of these practices, particularly now that the problem of cable fault voltage restriking has been eliminated by the adoption of the residual current compensation.

The “proof of the pudding will be in its eating” and the performance of the trial system will be monitored, analysed and reported in detail over the next 12 months.

We are therefore looking forward to a very interesting next 12 months in terms of monitoring the performance of the Darfield network, including some “live” fault testing to demonstrate the RCC capabilities.

These results should prove valuable to transmission and distribution system asset owners wishing to explore performance enhancing initiatives for their networks.

Appendix One

Voltage and current vector relationships - solid versus resonant grounded systems

Figure 1: Unearthed supply neutral

Current and voltage vector relationships – no fault present.  
Residual current as zero.

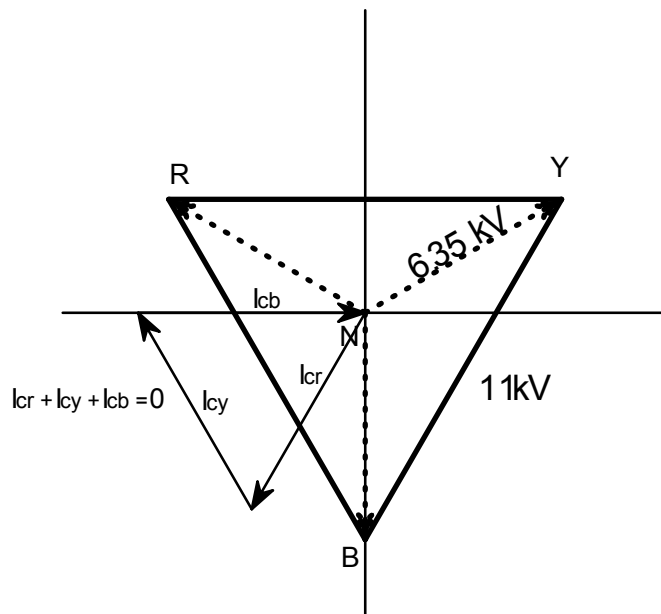
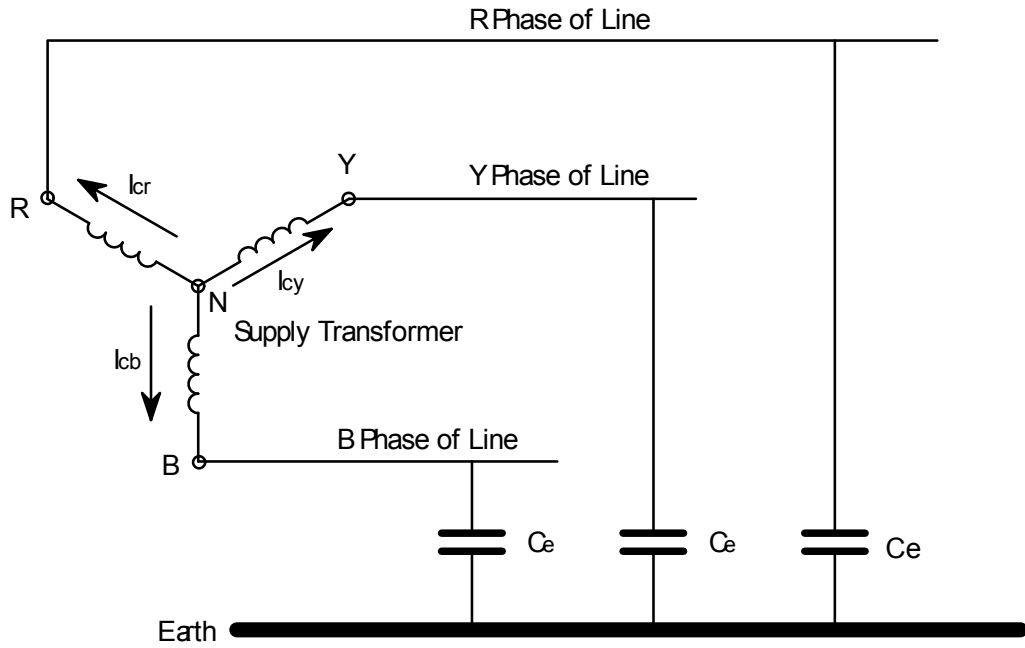

**Figure 2: Unearthed supply neutral**

**Current and voltage earth fault applied to an isolated neutral 3 phase, 3 wire MV supply network.**  
**Residual fault current is determined by capacitive to earth current flowing in the 2 unfaulted phases.**

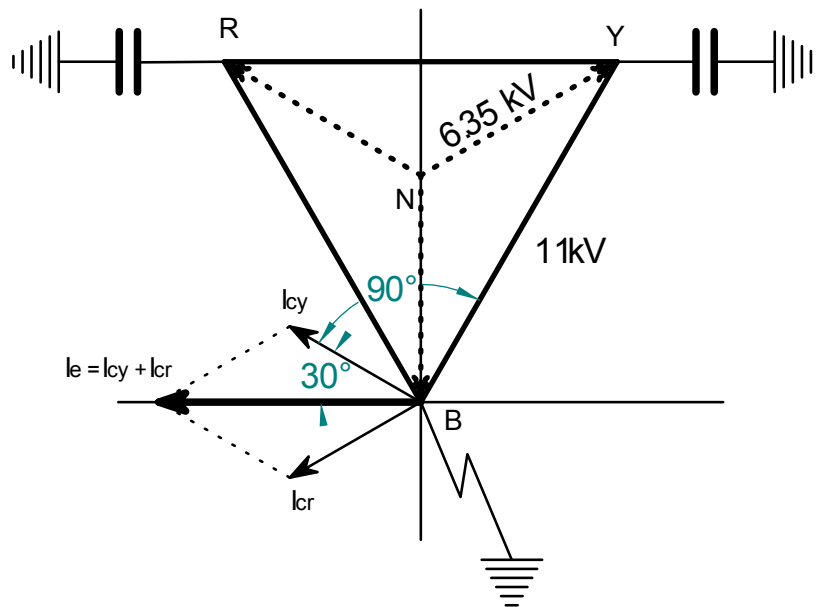
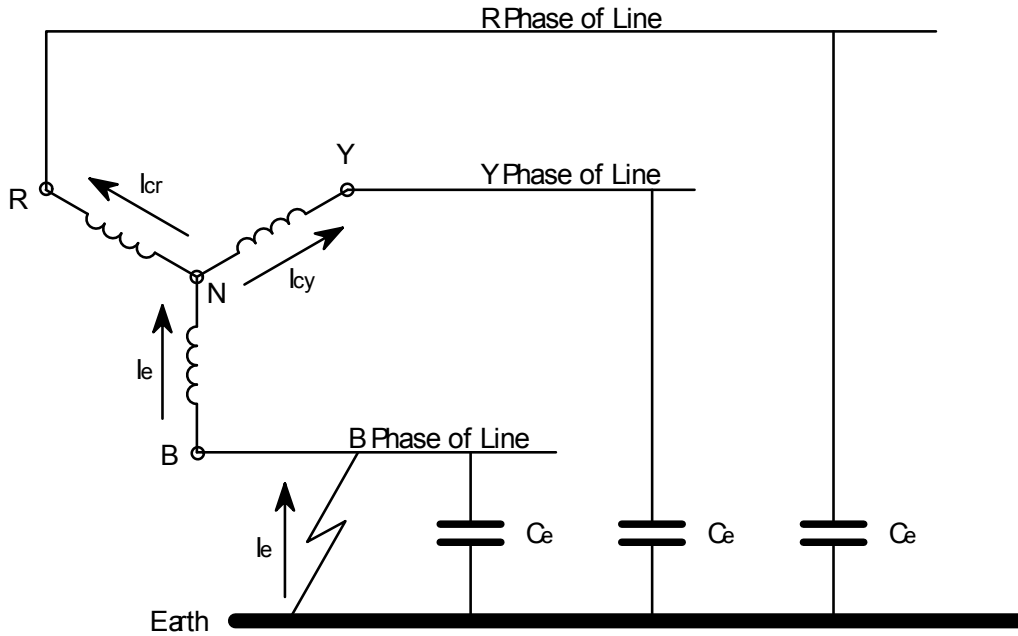

**Figure 3: Solidly earthed system**

**Simplified current and voltage vector relationship with no fault present.  
Residual current is zero provided the capacitance to ground of each phase is the same.**

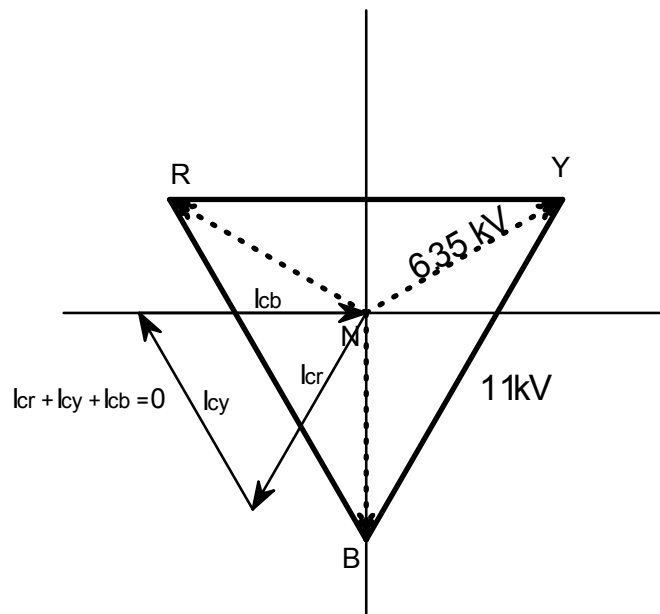
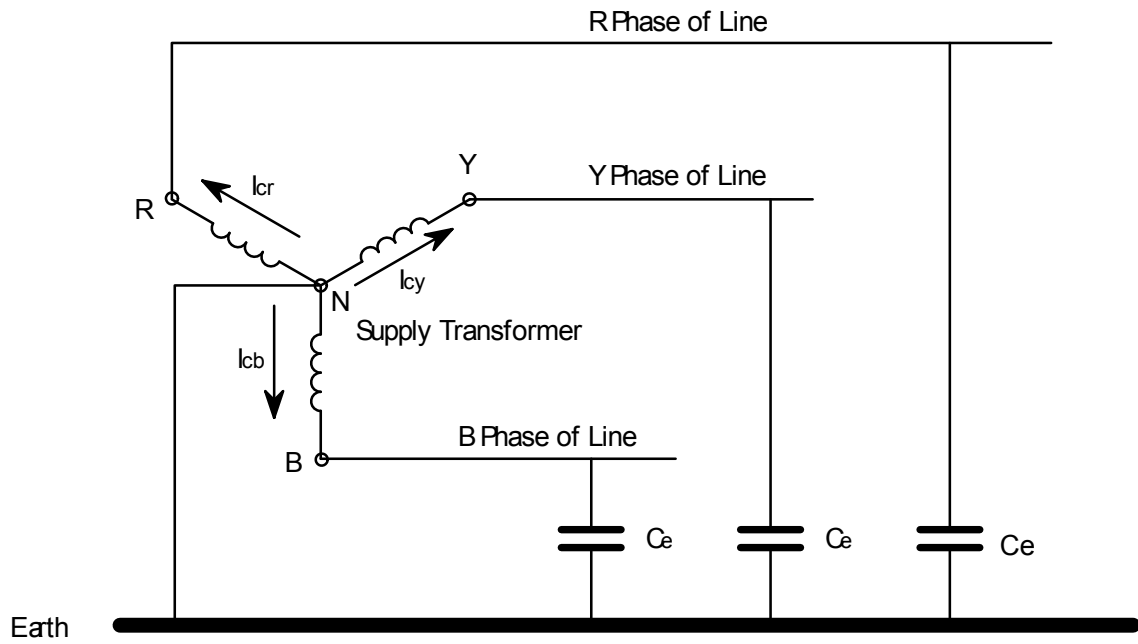

**Figure 4: Solidly earthed supply neutral**

**Simplified voltage and current vector relationships.  
For the case of a single phase to earth fault applied.  
Residual fault current is relatively high and determined largely by the zero sequence source impedance and the impedance at the point of fault.  
These are typically much lower than the capacitive line to ground impedances.**

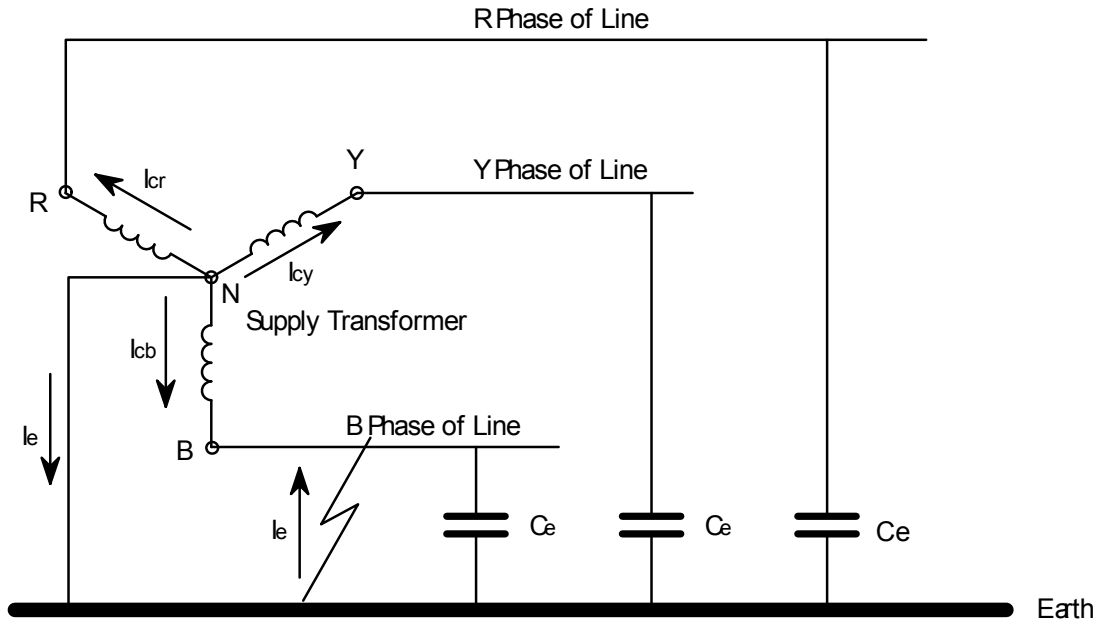

**Part Figure 4**

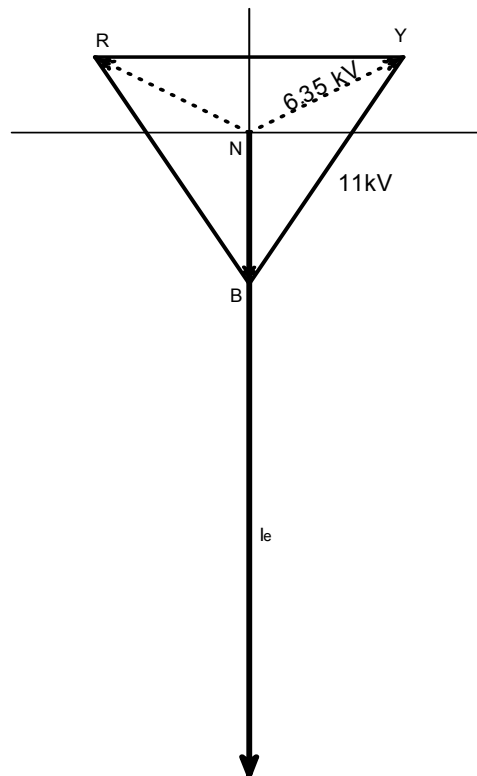
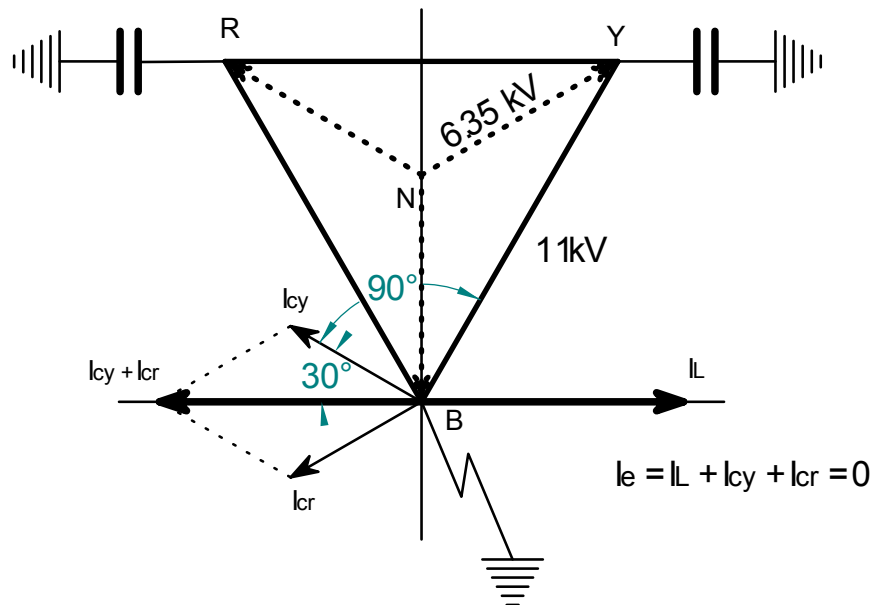
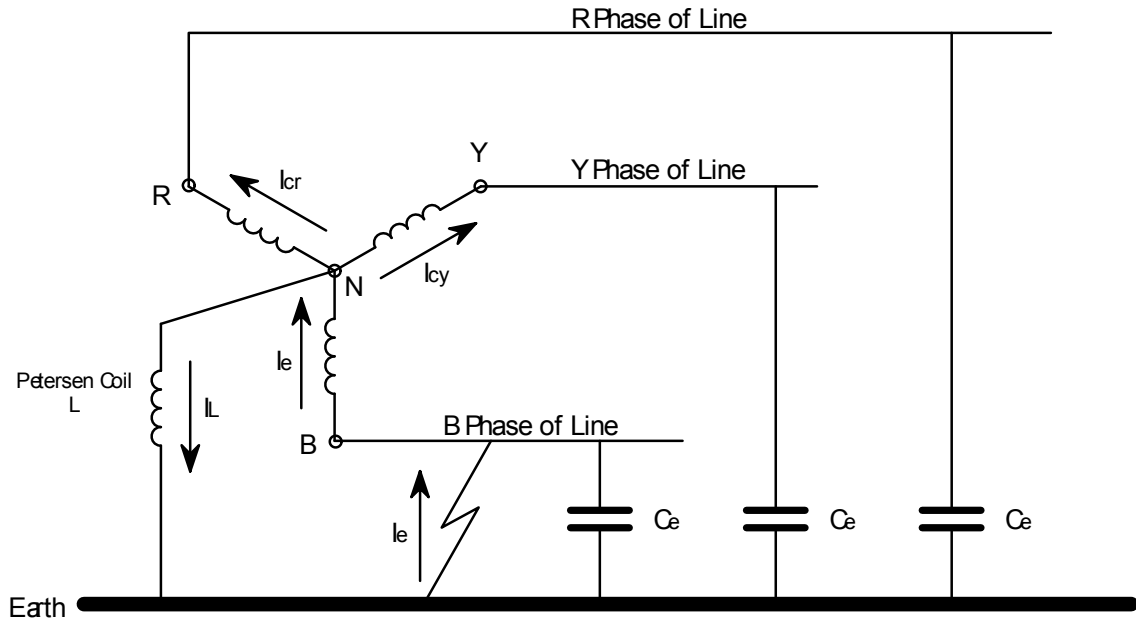

Figure 5: Petersen Coil earthed supply neutral

Current and voltage vector relationships for a single phase earth fault applied to a Petersen coil (resonant) grounded neutral 3 phase, 3 wire MV supply network.

The Residual Fault Current is reduced to zero provided the inductance coil current is equal to the sum of the capacitive ground currents flowing in the 2 unfaulted phases.



## Appendix Two Darfield substation Petersen coil and RCC system

Figure 1: Schematic diagram

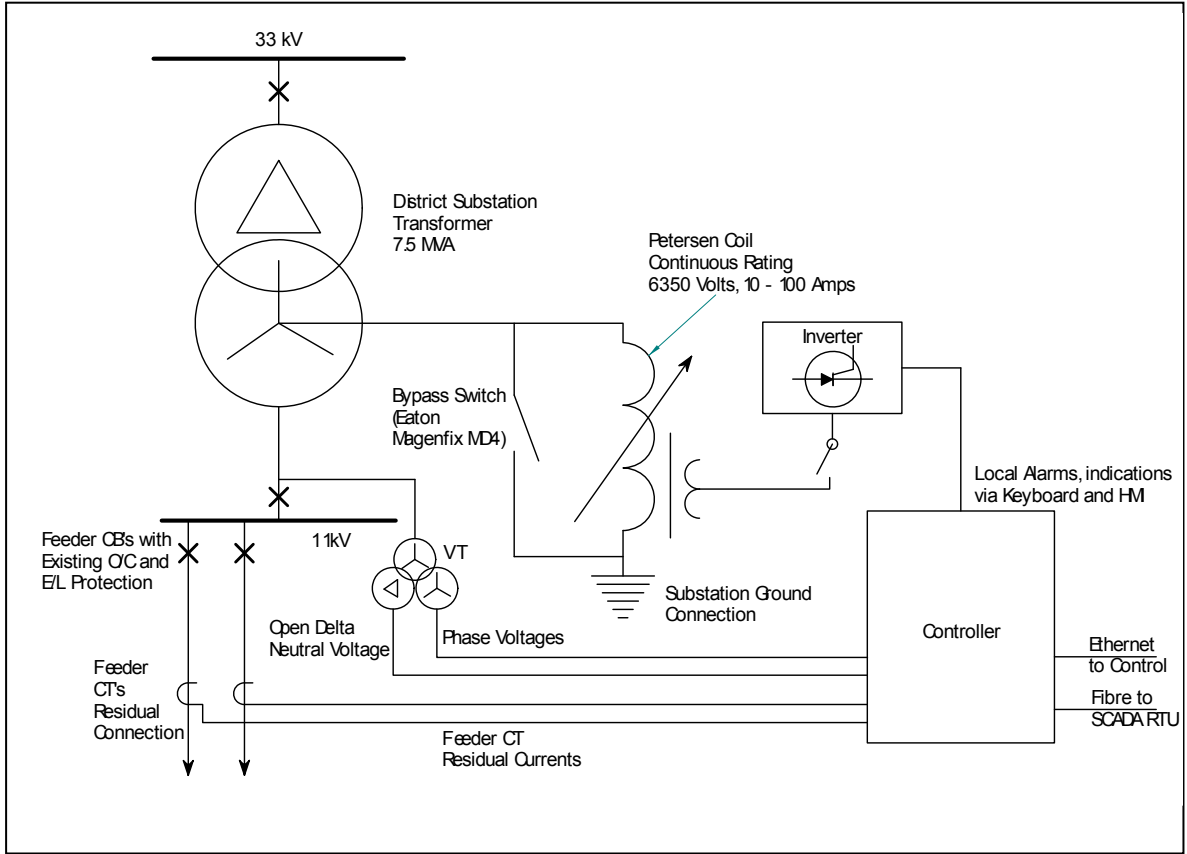
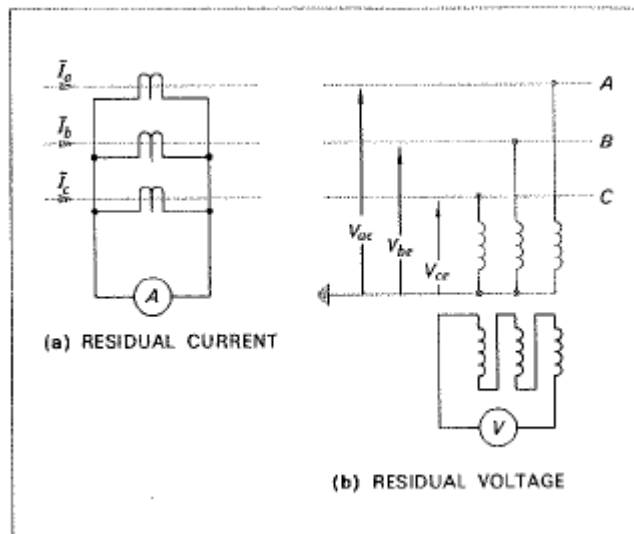
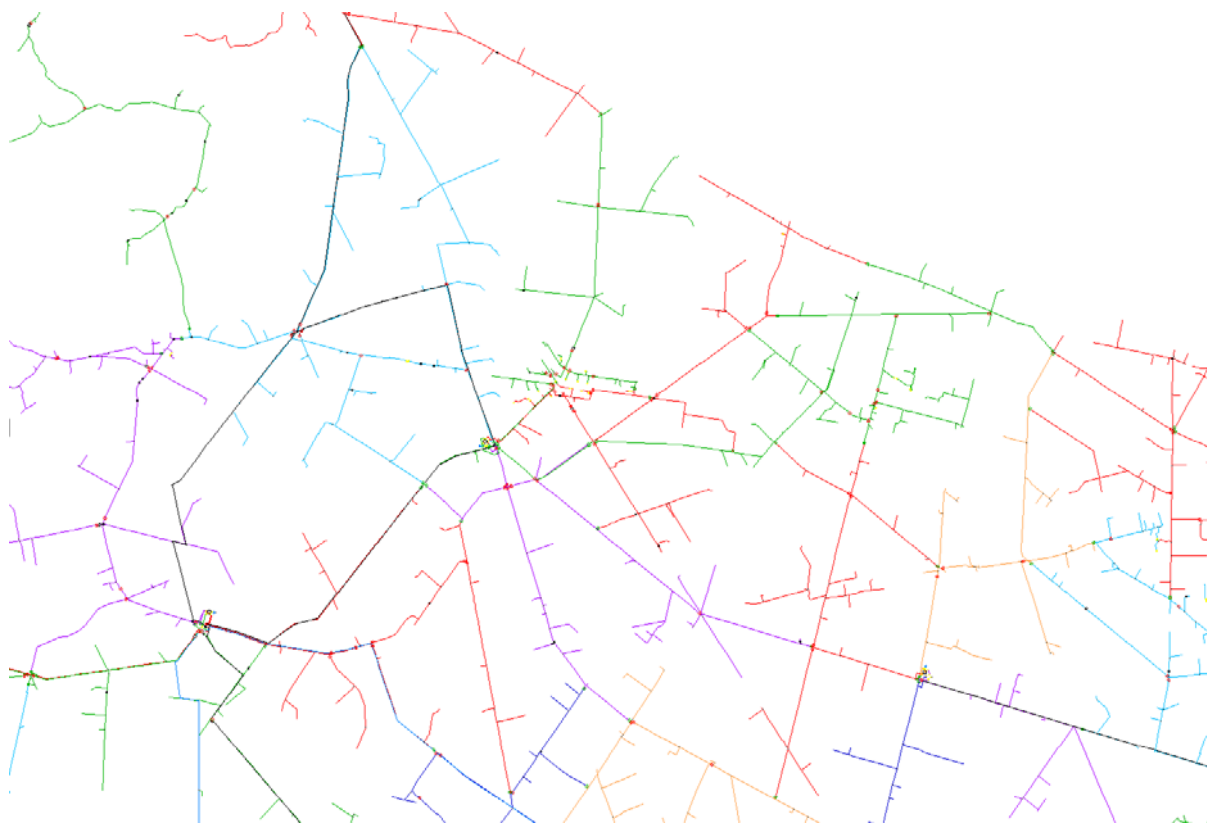
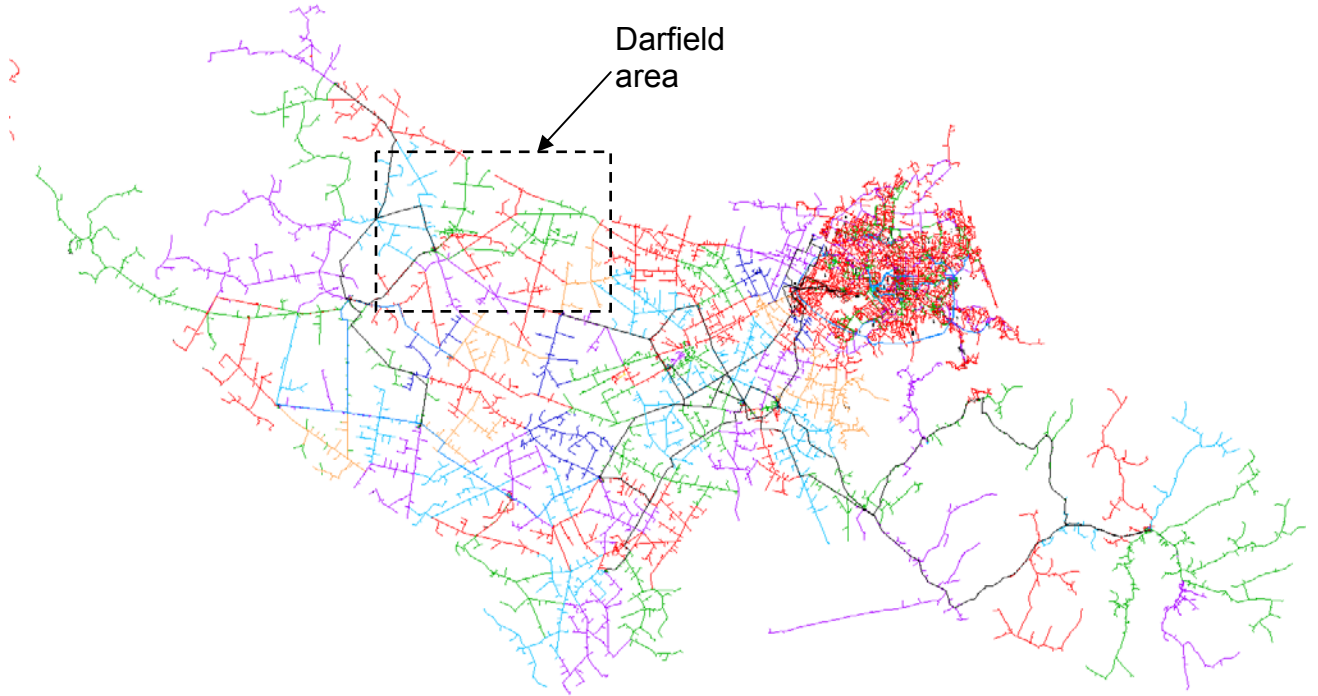

Figure 2: Residual current and voltage connections





**Appendix Three**  
**Map of Darfield network area**



**References**

- (1) A new deal for safety and quality on MV networks, D Griffel, V Leitloff, Y Harrand, J Bergeal, Electricite de France. IEEE transactions on power delivery, Vol 12, No. 4, October 1997.
- (2) Resonant earthing disadvantages and advantages; why do we not use it in New Zealand? S Hirsch, Orion New Zealand Limited, EEANZ Conference, June 2006.
- (3) The RCC ground fault neutraliser. A novel scheme for fast earth-fault protection, Klaus Winter, Swedish Neutral AB, 18th CIRED International Conference and exhibition on electricity distribution, Turin, 6-9 June 2005.

## Appendix G

### Resonant Earthing - Advantages and Disadvantages. Why Do We Not Use It in New Zealand?

Paper presented to the 2006 Electricity Engineer's Association Conference by  
 Stephen Hirsch  
 Control and Protection Systems Development Manager  
 Orion New Zealand Ltd.  
 Christchurch. New Zealand

#### Abstract

Resonant Earthing, i.e. earthing the electricity distribution network via a tuneable inductance (commonly known as a Petersen or Arc Suppression Coil) is widely and successfully used in many European and Scandinavian countries and in China, primarily at distribution voltages but also at up to 110 kV.

Resonant Earthing techniques have the capability of eliminating momentary interruptions on overhead power supplies due to transient earth faults and allow fault finding for permanent earth faults to be carried out while the power system is still alive, further reducing customer interruptions.

New Zealand's solidly earthed distribution systems with their high earth fault currents also expose many, but especially rural customers to extremely high earth potential rise (EPR) in the event of a high to low voltage conductor contact. These EPR events, although they are infrequent, may expose persons (both in the home and on telecommunication networks) to considerable risk of electric shock. Unless incoming telecom lines are isolated from the telephone exchange "remote earth", EPR can also severely damage mains powered telecommunication devices, e.g. FAX's and the telephone system they are connected to, possibly causing fires.

Resonant Earthing technology is capable of reducing earth fault currents to almost zero thus reducing EPR to insignificant levels.

Against these significant advantages, there are some potential disadvantages, e.g. difficult fault location and detection and increased voltages on healthy phases during faults, however techniques have been developed to mitigate these problems.

On balance there appear to be significant advantages to the use of resonant earthing on electricity distribution systems. Why does no one in New Zealand use the technology?

#### Introduction to Power System Earthing

Early in the 20<sup>th</sup> century, electric power generation, transmission and distribution systems were rapidly expanding; voltages were increasing and the technology being used was improving rapidly. AC systems (Westinghouse) were the technology of choice and three phase transmission and distribution with each phase voltage displaced by 120 degrees, caught on very early when it was realized that there were significant advantages in using a three phase system in the design and construction of large rotating electrical plant.

There are two basic methods of connecting three phase system sources and/or loads: delta or wye. In either case you could supply your single and/or three phase loads connected phase to phase with no reference to "earth" and many early systems did so. As voltages increased and systems grew in size, problems started to arise when "earth" faults occurred on these unearthed systems. Quite large amounts of current would flow at the fault location, electrical arcs could be generated and nasty transient high voltages to earth would appear on the healthy phases, sometimes causing insulation breakdown elsewhere in the network. There might be no metallic connection to earth but there was still plenty of capacitance between the conductors and the "earth" providing an earth fault current path.

The obvious thing to do to solve the transient overvoltage problem was to tie down the voltages by connecting a wye connected source or load to earth and if you ran an additional fourth conductor you could connect your single phase loads phase to neutral at a lower (safer?) voltage. The Americans extended the four wire topology to their high voltage systems (which avoids nasty things

like ferroresonance in transformers but introduces other problems, e.g. the danger of broken neutrals and stray voltages due to unbalanced neutral currents) while the Europeans restricted it to LV systems. Earthing the neutral solved the transient overvoltage problem and made it much easier to locate and isolate earth faults (just look for the flash and cloud of smoke). However it meant that you now had very high prospective fault currents to earth with resulting high earth potential rise (EPR) and step and touch potentials at the fault location with consequential risk to life and limb from shock and fire. So as a compromise, neutral earthing resistors (NER) were used to reduce the earth fault current somewhat but still retain control over transient over-voltages.

For urban underground networks with solidly bonded high voltage cable sheaths/screens and/or larger interconnected multiple earthed neutral (MEN) low voltage systems, NER's work very well. For overhead networks supplying single isolated customers from a distribution transformer however, it is frequently impractical either to get a low enough MEN resistance or be able to use a high enough NER resistance to reduce the EPR to acceptable levels.

In all earthing methods discussed above, unearthed, solidly earthed and resistance earthed, you still need to disconnect the power supply to interrupt an earth fault, which although it may frequently be caused by a transient contact, usually still results in an arc which will not self extinguish. Auto-reclosing is thus employed to try to restore the supply to customers as quickly as possible. Customers used to put up with the blinking lights caused by an auto-reclose sequence but they are getting much more dissatisfied about their modern electronic equipment (clocks, washers, stereos, PC's etc.) being subjected to such treatment.

### Resonant Earthing

In 1916, Professor W. Petersen was granted German patent 304823 for a novel method of earthing a three phase power system. If you place a tuneable reactor between the supply transformer neutral and earth (you can also do the same with an earthing transformer) and adjust its inductance until the inductive current in the reactor during an earth fault is equal in magnitude to the capacitive current flowing into the two unfaulted phases, no current will flow into the earth fault and hence any arc will self extinguish.

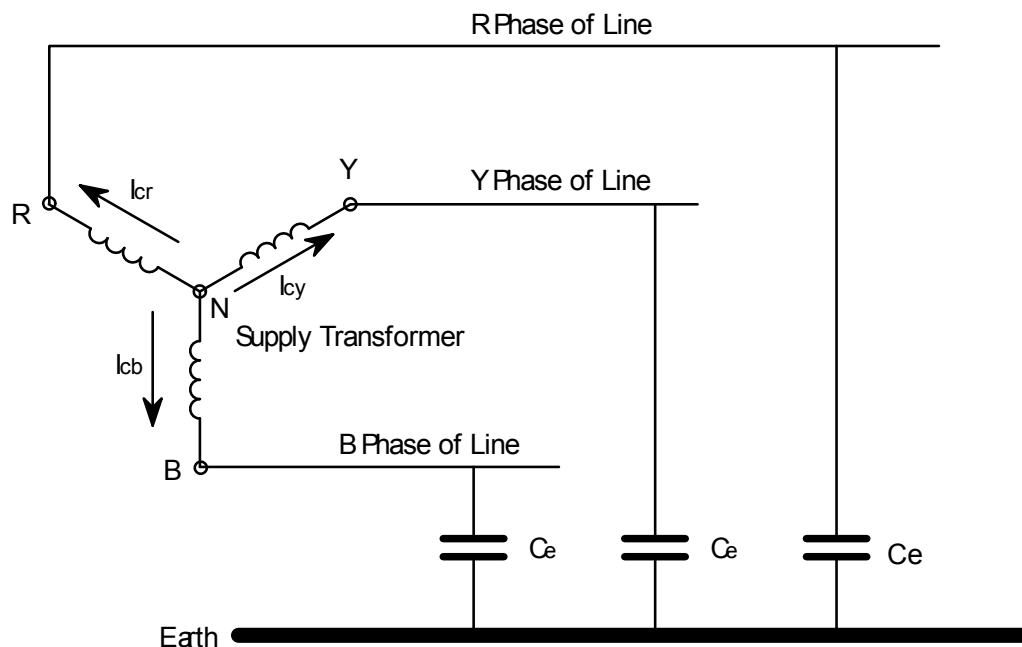
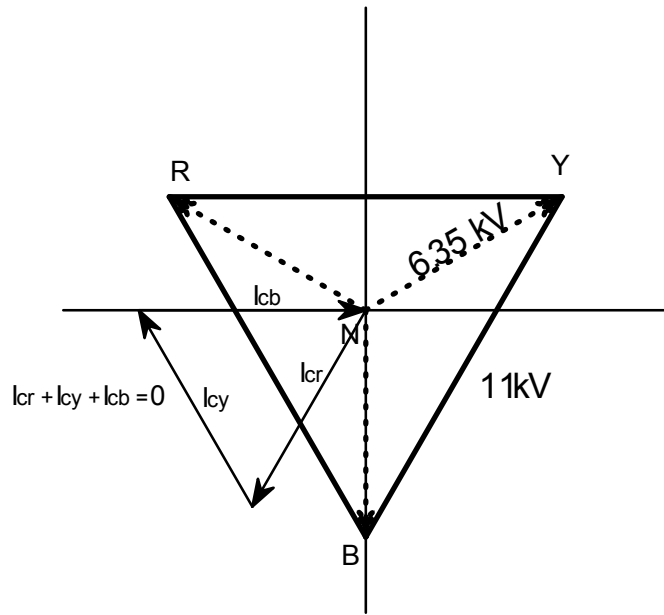
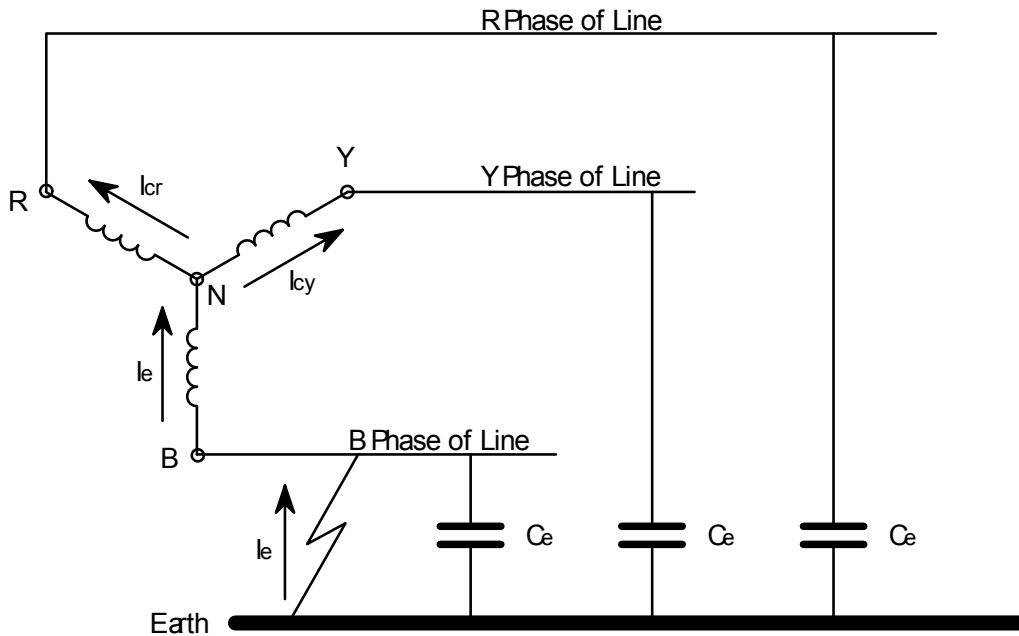

Figure 1 Unearthed system – normal operation

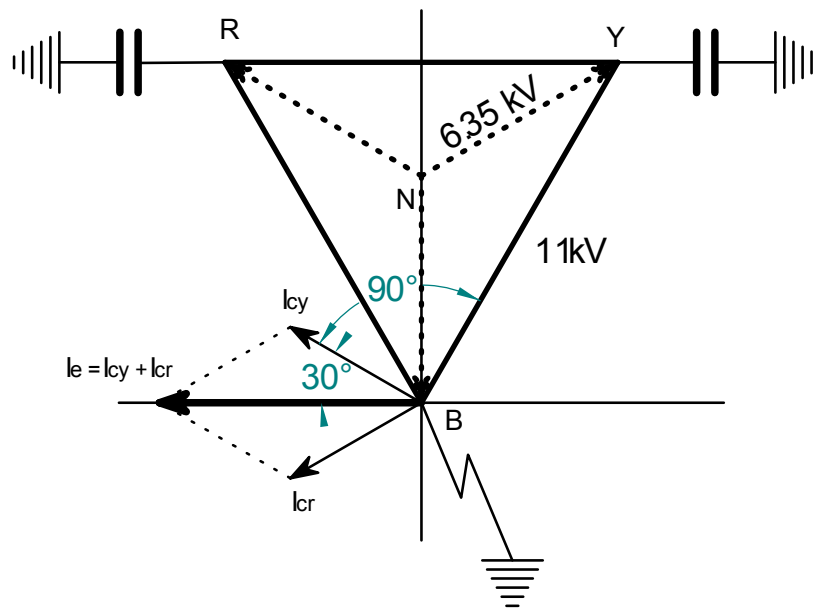

**Figure 2 Unearthed system – normal operation - vector diagram**

Figure 1 and 2 above show an ideal unearthed, balanced, unfaulted 11 kV system with voltage and current vector diagram; the neutral of the supply transformer is at earth potential and the individual phase capacitive charging currents are equal in each phase, displaced by 120 degrees and thus add to zero at the transformer neutral.



**Figure 3 Unearthed system with earth fault on Blue phase**



**Figure 4 Unearthed system with earth fault on Blue phase – vector diagram**

We now apply an earth fault to one of the phase conductors so that the potential on the faulted phase is zero or at earth potential. The voltage on the supply transformer neutral will float up to the phase to neutral voltage, the voltage on the faulted phase will drop to zero and the sum of the capacitive line currents in the unfaulted phases will flow in the earth fault.

In a typical New Zealand rural, mainly overhead distribution system supplying about 200 km of overhead line, the capacitive residual current could be 20 Amps or more. Include some underground cable with its much higher capacitance and the residual current may be over 30 Amps. A 30 Amp arc will not normally self extinguish and thus even if the fault that caused the arc to form in the first place is transient, the power supply must be disconnected to extinguish the arc.

Another problem with unearthed systems is caused by the fact that the circuit breaker used to disconnect the fault will typically interrupt the arc near current zero when the voltage is near its maximum value (the capacitive current leads the voltage by 90 degrees). This voltage remains on the line as the source voltage goes to its maximum negative value resulting in 2.0 pu. voltage across the breaker contacts. A voltage of this value may cause the arc to re-strike across the breaker contacts sending the line voltage from +1 to -1 pu. This results in a high frequency transient voltage whose first peak overshoots the -1.0 value by -2.0 (the difference between -1 and +1), giving a peak value of -3.0. If the arc is again extinguished, the trapped charge results in a voltage of -3.0 pu. If a second re-strike occurs at the next source positive voltage maximum the process repeats with the voltage increasing each time until insulation breakdown occurs.

In reality, circuit resistance will introduce damping and the re-strikes may occur before the voltage reaches its crest value but nevertheless the over-voltages can be very high and represent the major disadvantage of unearthed systems.

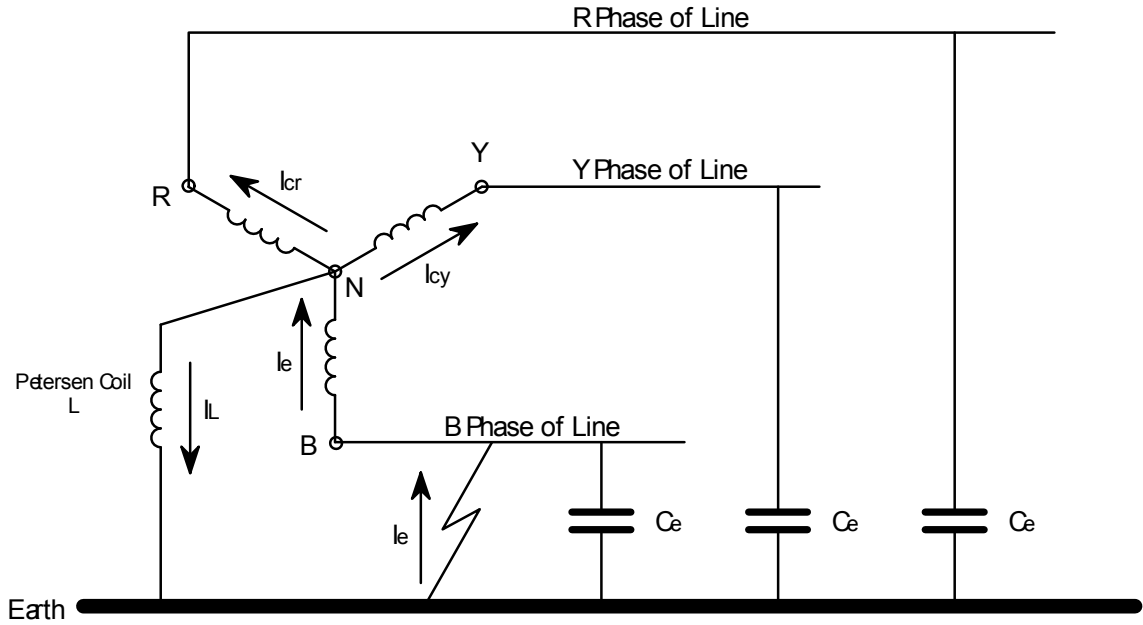

**Figure 5 Resonant Earthing with earth fault on Blue Phase**

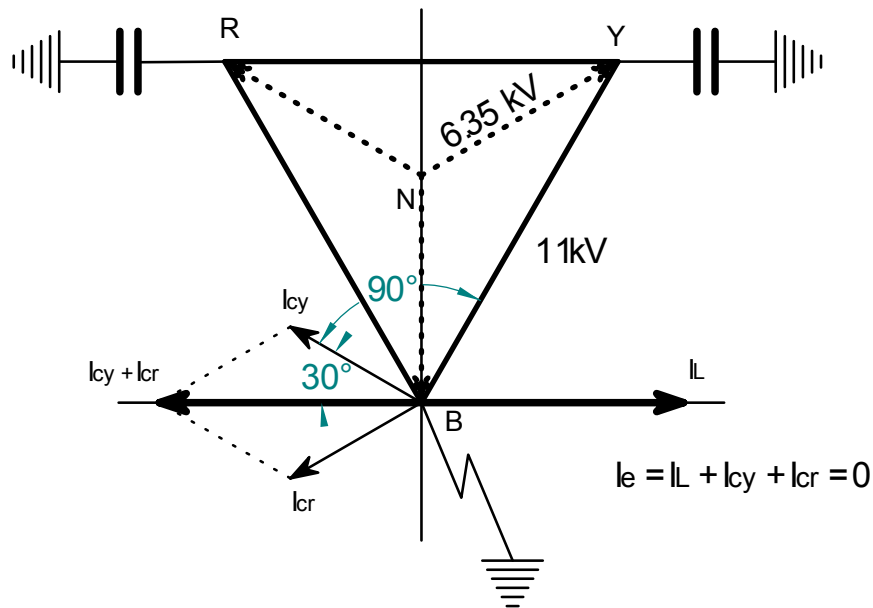

**Figure 6 Resonant Earthing with earth fault on Blue phase – vector diagram**

We now take the unearthed network described above and place a reactor from the supply transformer neutral to earth and adjust or tune its inductance so that the current in the reactor with line to earth voltage across it, is equal in magnitude to the magnitude of the sum of the capacitive currents flowing in the two unfaulted phases. Because the current in the reactor and the capacitors is 180 degrees out of phase, the sum of the currents in the transformer neutral will be zero and hence no current will flow in the faulted phase.

Intuitively this is hard to understand, but it really does work.

A further advantage with resonant earthed systems is that the voltage across the fault will recover very slowly after the arc is extinguished. In an ideal perfectly symmetrical network with no losses, after the earth fault is removed, there will be nothing to restore the transformer neutral voltage to zero or earth potential and the voltages will remain as shown in Figure 3.

In the real world however resistance/losses in the lines, transformer and Petersen coil will gradually restore the system voltage to a (more or less) symmetrical state. Depending on network losses the voltage recovery can take up to 10 or more cycles. This gradual voltage recovery assists with extinguishing arcs.

### **Why Not Use Resonant Earthing – The Advantages**

#### **1. Reduction of EPR.**

Rural electricity customers in New Zealand have been traditionally supplied by means of three wire, 11 kV (or 6.6 or 22 kV) overhead line networks, solidly earthed at a single point, at the zone substation. The LV supply to the customer is derived from a dedicated pole mounted distribution transformer with combined HV and LV earthing.

In areas of high soil resistivity, these customers can have their local MEN installation subjected to relatively high levels of EPR, (5000 volts or more for an 11 kV system, even higher for 22 kV), when faults which involve contact between the HV and LV systems, for example transformer HV to LV winding breakdown, HV conductors falling into LV conductors etc., occur at or near the distribution transformer pole. These are admittedly infrequent events, possibly 1 to 5 per year in New Zealand, but for the reasons explained below the consequences can be drastic in some cases.

Twenty years ago the only remote earth in a customer's premises other than the power supply MEN was the telecom pair and these were insulated and connected to a line powered plastic telephone which conveniently provided reasonable isolation for the user.

Nowadays however we have seen a proliferation of mains powered telecommunication equipment, FAX's, PC modems etc. many of which intentionally connect the telecom pair to the MEN via surge protection devices. Place 5 kV across these devices and they conduct 100's of Amps into the telecom pair and explode, possibly setting fire to the device to say nothing of the damage done to the telecom pair or anyone working on the telecom network at the time.

International appliance standards including Telecom New Zealand's Telepermit system are woefully inadequate in this area and blissfully assume that EPR voltage will be limited to the much lower voltages typically seen in large urban areas.

Compounding the problems above, in the past few years we also have seen a huge increase in the number of lifestyle properties in the rural areas surrounding our cities, each of which is typically supplied by its own distribution transformer. Thus the exposure to high EPR levels has increased dramatically in the past 20 years.

The concern is that there is an increasing likelihood that someone is going to suffer severe injury or death due to an EPR event, either by fire or electrocution.

The Energy Safety Service of the Ministry of Economic Development have been watching international developments, specifically IEC shock safety standards such as IEC60479 and are getting understandably nervous about the very high EPR levels that many New Zealand customers are potentially exposed to. There are proposals to change the 10 ohm MEN requirement specified in the Electricity Regulations (which certainly does not confer safety in any conceivable way) to a performance based requirement most likely based on the IEC shock standard. Probably the only feasible way of meeting the requirements of the IEC shock standard in isolated rural supplies is with the use of resonant earthing.

#### **2. Reduction in auto-reclose operations**

In Orion's network, it appears that approximately 50% of faults are earth faults (some networks report an even higher percentage of earth faults, up to 75%) and a high proportion of these are transient. Resonant earthing will eliminate auto-reclose operations due to transient earth faults.



Currently distribution networks do not have to report on momentary interruptions less than 1 minute, however with the proliferation of electronic equipment in homes, customers are becoming less and less tolerant of such interruptions which are increasingly seen as a major irritant and indicator of poor power quality in rural areas.

### 3. Fault finding with the distribution network alive

In some countries it is permissible when using resonant earthing under defined conditions, to leave the distribution network alive with an earth fault on it while fault finding.

This introduces the possibility of dramatically reducing network outages and customer minutes lost due to earth faults.

## The Disadvantages of Resonant Earthing and Possible Solutions

### 1. Difficult fault location

One of the perceived major disadvantages of resonant earthing is the difficulty of detecting and locating faults. Traditional sensitive earth leakage protection will generally not work since the fault currents are too low.

If you do need to trip feeders or re-closers for permanent earth faults in a resonant earthed system you either need to install very sensitive directional earth fault protection relays or provide a switchable NER to bypass the arc suppression coil thus causing the earth fault to draw enough current to get traditional protection equipment to operate. Of course the use of an NER reduces the advantage of the greatly reduced EPR obtained by the use of resonant earthing.

**Solution:** If fault finding with the network alive is allowed, it is thus not necessary to trip breakers for earth faults. Resonant earthing control equipment itself can indicate the faulty feeder at the substation and pole-mounted fault locators are available which are capable of detecting earth faults up to about 1000 ohms in a resonant earthed network. This is equivalent to around 5 Amps earth fault current in a traditional solidly earthed 11 kV network.

To be able to fault find with the network alive would require an exemption from Electricity Regulation 62 which currently requires that earth faults be cleared in no more than 5 seconds.

### 2. Cross country earth faults

On a resonant earthed system, during an earth fault on one phase, the healthy phases are exposed to normal line to line voltage to earth rather than the normal phase to neutral voltage. This may stress the insulation on the healthy phases and cause a second earth fault on one of the healthy phases, usually at a different location to the initial fault. This is known as a cross country earth fault. Note that NER's also displace the power system neutral and hence also increase the voltage on the healthy phases.

**Solution:** Basic insulation level (BIL) at distribution voltages is usually very high relative to maximum operating voltage. For instance at 11 kV it is typically either 75 or 95 kV which should give a very healthy operating margin. Experience with NER's indicates that cross country faults should not be a significant problem. Orion has used NER's for many years and has only documented one incidence of a cross country earth fault which was caused by a faulty CT primary. Cross country faults if they do occur can be cleared using standard earth fault protection.

### 3. Restriking cable faults

In the real world, networks are not completely symmetrical. We do not transpose phases (yellow phase is usually in the middle in a flat construction), we have sections of two phase line and real lines have resistance and unbalanced loads. These factors mean that the capacitive residual currents do not completely balance out in the supply transformer neutral and thus there will still be some residual earth fault current. These residual earth fault currents may be in the range of 3 to 5 amps in a typical, reasonably balanced rural New Zealand distribution network.

Although arcs caused by transient faults on overhead systems are reliably extinguished in resonant earthed systems even with some residual earth fault current, cable faults are more

problematic. Most overhead faults are caused by transient or permanent contact with earthed objects, both situations handled satisfactorily by tradition resonant earthing.

Cable faults are usually caused by insulation breakdown which leaves a partially defective insulation path between the phase conductor and earth.

Faults such as this tend to break down and arc due to the residual current, the arc extinguishes and then as the phase voltage recovers they break down and arc again and again. This repeatedly stresses the insulation on the healthy phases making cross country faults more likely and also slowly destroys the cable insulation at the fault location.

**Solution:** Electronic residual earth fault current compensation equipment is now available which is capable reducing the residual current to zero which not only solves the problem of restriking cable faults but also makes the network much safer in general during earth faults by forcing the faulted phase voltage to zero thus making fault finding alive acceptable.

### **Conclusions**

New Zealand (and Australian) distribution network design has evolved from traditional UK practice which emphasised the importance of solidly earthing the supply transformer neutral to avoid transient over-voltages and to ensure that there would be adequate earth fault current to operate traditional over-current protection – the standard (and only acceptable) setting used to be 10% of CT rating. These practices have become enshrined in the Electricity Regulations – only recently were we even allowed to use NER's.

Perversely, in the UK where these practices arose, the regulations allow the use of resonant earthing including fault finding with the network alive and there are many older resonant earthed systems in service with increasing numbers of new systems being installed.

Traditional resonant earthing has significant advantages in terms of reduction in EPR and momentary power supply interruptions due to transient faults in overhead systems. The addition of residual earth fault current compensation reduces the residual earth fault current and the voltage on the faulted phase to zero, thus solving the problem of restriking cable faults and making it safe to fault find earth faults with the distribution network alive.

Why do we not use resonant earthing in New Zealand?