



SAVONIA

■ THESIS - BACHELOR'S DEGREE
TECHNOLOGY, COMMUNICATION AND TRANSPORT

SHORT-CIRCUIT WITHSTAND CURRENT RATING FOR LOW VOLTAGE SWITCHGEAR

Short-Circuit Current Rating (SCCR)

Author: Matthias Christian Schütt

Koulutusala Tekniikan ja liikenteen ala		
Koulutusohjelma Sähkötekniikan koulutusohjelma		
Työn tekijä(t) Matthias Christian Schütt		
Työn nimi Pienjännitteisen sähkökeskuksen oikosulkukestoisuus		
Päiväys 06.06.2016	Sivumäärä/Liitteet	68 / 7
Ohjaaja(t) lehtori Jari Ijäs		
Toimeksiantaja/Yhteistyökumppani(t) E Avenue Oy		
Tiivistelmä <p>Opinnäytetyön aiheena oli tarkastella sähköjakokeskusten oikosulkuvirtoja. Ajatuksena oli tutkia eri menetelmiä, miten sähköjakokeskuksia voidaan suojata oikosulkuvirran aiheuttamilta vahingoilta. Valmistajien täytyy ilmoittaa sähköjakokeskusten ehdollinen oikosulkukestoisuus. Tarkoitus oli löytää menetelmiä, joilla oikosulkukestoisuus voidaan määritellä oikein.</p> <p>Tämä opinnäytetyö esittelee teoreettista tietoa oikosulkuvirran syistä ja niiden vaikutuksista kojeistoihin. Laskentamenetelmien ja verkostolaskentaohjelmistojen avulla määritettiin, kuinka merkittävä oikosulkuvirran suuruus on. Opinnäytetyössä on käsitelty oikosulkuvirran suuruutta rajoittavia menetelmiä, kuten suojalaitteet, virtaa rajoittavat katkaisimet ja sulakkeet sekä suojamenetelmät, kuten selektiivisyys ja back-up-suojaus.</p> <p>Teoreettisen tuloksen avulla esitetään käytännön esimerkki, kuinka määritetään sähköjakokeskuksen oikosulkukestoisuus ja miten monimutkainen prosessi se on. Lisäksi yhtiö sai kattavaa tietoa nimellisestä oikosulkulujuusluokituksesta.</p>		
Avainsanat oikosulkuvirta, virran rajoittaminen, oikosulkukestävyys, suojalaitteet, selektiivisyys		
Luottamuksellisuus julkinen		

CONTENTS

1	INTRODUCTION	8
2	E AVENUE OY	9
2.1	History	9
2.2	Products	9
2.3	Quality, environment and corporate responsibility	10
2.3.1	ISO 14001	10
2.3.2	PYR-Label	10
2.3.3	Reliable partner	10
3	STANDARDS	11
3.1	Switchgear manufacturing demanded standards	11
3.2	Switchgear appearing current ratings	13
3.2.1	Rated current (I_n)	13
3.2.2	Rated current of the assembly (I_{nA})	13
3.2.3	Rated current of a circuit (I_{nc})	14
3.2.4	Rated peak withstand current (I_{pk})	14
3.2.5	Rated short-time withstand current (I_{cw}) (of a circuit of an assembly)	14
3.2.6	Rated conditional short-circuit current of an assembly (I_{cc})	14
3.2.7	Rated diversity factor (RDF)	14
3.2.8	Cut-off current I_D	15
3.2.9	Joule integral I^2t	15
4	SHORT-CIRCUIT - THEORETICAL BACKGROUND	16
4.1	Different types of short-circuit	16
4.2	Development of the short-circuit currents	17
4.3	Characteristics of short-circuit currents	18
4.3.1	Maximum short-circuit current	20
4.3.2	Minimum short-circuit current	21
4.3.3	Prospective short circuit current	21
4.3.4	Thermal equivalent short-circuit current (I_{th})	21
4.3.5	Peak short-circuit current (I_p)	23

5	CALCULATIONS.....	25
5.1	One-phase short-circuit current calculation	25
5.2	Standardised short-circuit current calculations	25
5.3	Calculation of short-circuit current by the impedance method	26
5.4	Calculating short-circuit current using the "composition method"	28
6	SHORT-CIRCUIT CURRENT LIMITING	30
6.1	Short-circuit current limiting circuit breaker	31
6.2	Short-circuit current limiting fuse	32
6.3	Current-Limiting Fuse Let-Through Charts	33
6.4	Current-limiting transformers.....	34
6.5	Short-circuit switching capacity	35
6.5.1	Rated short-circuit making capacity I_{cm}	36
6.5.2	Rated short-circuit breaking capacity I_{cu} and I_{cs}	36
7	PROTECTIVE DEVICE COORDINATION.....	37
7.1	Selectivity.....	37
7.1.1	Selectivity categories.....	38
7.1.2	Current selectivity	39
7.1.3	Time selectivity	40
7.1.4	Zone selectivity	41
7.1.5	Selectivity between fuses.....	41
7.1.6	Selectivity between fuses and circuit breakers.....	42
7.1.7	Selectivity table.....	43
7.2	Backup protection	43
8	SWITCHGEAR SHORT-CIRCUIT CURRENT WITHSTAND RATING	45
8.1	Short-circuit impact on switchgear	45
8.2	Short-circuit current rating (SCCR)	45
8.3	Determining the rated short-time withstand current (I_{cw}) of a circuit of an assembly.....	46
8.3.1	Relationship between peak current and short-time withstand current	51
8.3.2	Thermal effects of short-circuit on busbar.....	51
8.4	Short-circuit current rating with current-limiting circuit breaker.....	52
8.5	Short-circuit current rating with current-limiting fuse.....	54

9	SHORT-CIRCUIT CURRENT CALCULATION TOOLS.....	58
10	EXAMPLE PROJECT ANALYSIS	59
10.1	Calculations for the short-circuit currents.....	60
10.2	Determination of SCCR.....	62
11	CONCLUSION.....	65
12	REFERENCES	66
	APPENDIX 1: ANALYZED NETWORK.....	69
	APPENDIX 2: SWITCHGEAR RKA-L6.1 DESIGN.....	70
	APPENDIX 3: SWITCHGEAR RKA-L6.1 CUSTOMER WITHSTAND DEMANDS.....	71
	APPENDIX 4: BUSBAR DATASHEET	72
	APPENDIX 5: MCMKA 4X95/50 CABLE DATASHEET.....	73
	APPENDIX 6: EXAMPLE NETWORK WITH ABB EDESIGN DOC.....	75

LIST OF ABBREVIATIONS

U_n	rated voltage
I_n	rated current
I_{nA}	rated current of an assembly
I_{cc}	rated short-circuit current
I_{cp}	prospective short-circuit current
I_{cw}	rated acceptable short-circuit current
I_p	peak short-circuit current
I_{pk}	rated peak withstand current
$I_k = I_c$	steady-state short-circuit current; the r.m.s. value of the symmetrical a.c. component of a prospective short-circuit current persisting after all transient phenomena have died away
I_k''	initial symmetrical short-circuit current; the r.m.s. value of the symmetrical a.c. component of a prospective short-circuit current at the instant the short circuit occurs if the short-circuit impedance retains its value at time zero
I_k'	transient short-circuit current
S_k''	initial symmetrical (apparent) short-circuit power; a fictitious quantity calculated as the product of initial symmetrical short-circuit current I_k'' , nominal system voltage U_n and the factor $\sqrt{3}$
RDF	Rated diversity factor

1 INTRODUCTION

The aim of the thesis is to determine the effect of short-circuit currents at low voltage switchgears and how to determine the proper dimension of the installed devices, equipment and busbars. A proper protection against the consequences of a short-circuit is one of the most fundamental safety measures for electrical equipment. It is important to minimize the effects in order to protect persons and the material. For operational reasons it is often desirable that devices survive short-circuits largely unscathed so that they may become operational again as quickly as possible afterward. (Rockwell Automation, 2016, p. 37)

This thesis is done in cooperation with E Avenue Oy. The idea of this project came from the fact that several times there have appeared problems with short-circuit current sustainability regulations for low voltage switchgears. The company is missing clear guidelines for "short-circuit current rating" (SCCR) or also referred to as "short-circuit current withstand rating". Having such guidelines would enable E Avenue Oy to design their switchgear in a more cost efficient way within the standard limits and help their customers to rate the correct short-circuit current. The company's desire would be to have a tool where the needed short-circuit current rating could be calculated quickly and then compared with the values demanded by the potential customer.

The purpose of the work is to get familiar with the theory of short-circuit currents, the possible cause, magnitude, development and its effect on switchgears. An example of short-circuit current calculation is shown as well as methods of limiting short-circuit currents by protective devices and further how to ensure possible low impact on electrical networks by coordinating these protective devices by methods of selectivity and back-up protection

Network analysis software is introduced, which helps to quickly calculate the short-circuit current at different points of a network and it suggests suitable protective measures.

2 E AVENUE OY

E Avenue Oy is one of the largest manufacturers of power distribution boards under 1000V in Finland. The company employs around 150 people and has production facilities at four locations in Iisalmi, Ikaalinen, Kerava and Kuopio. The turnover is around EUR 15 million. The company is owned by five private individuals. (E Avenue Oy, 2015)

2.1 History

E Avenue Oy came into existence in 2004 as the result of a merger between two competing manufacturers of electricity distribution boards, Ikaalisten Keskussähkö Oy and Kuopion Kojeisto Oy. Both companies had a history of about 20 years. Ikaalisten Keskussähkö was founded towards the end of 1992 and Kuopion Kojeisto at the beginning of 1993. Each of E Avenue's production facilities specialises in its own manufacturing sector, working in collaboration with one another. (E Avenue Oy, 2015)

2.2 Products

The power distributions boards manufactured are among the very best in the industry. The safety and quality of the products are the cornerstones of the operations. All of the products are of FI-certified quality. Only the best components from renowned manufacturers that can also be found from the wholesalers' assortments are used. The customers will be able to get all the distribution boards they need from a single manufacturer, from standard apartment building boards to 8500A industrial switchgear assemblies. (E Avenue Oy, 2015)

The different branches have following specialisations:

- The Iisalmi branch specialises in the serial production of small control and power panels. It also provides software solutions to meet the needs of machinery and equipment manufacturers.
- The Ikaalinen and Kerava branches specialise in distribution boards for public buildings.
- The Kuopio branch specialises in heavy-duty industrial switchgears for customers in Finland and abroad. (E Avenue Oy, 2015)

E Avenue is and will be at the leading edge of its field that the competitors seek to emulate. Thanks to their high capacity and substantial expertise, they are able to provide customers with faster, better and more comprehensive service. (E Avenue Oy, 2015)

2.3 Quality, environment and corporate responsibility

E Avenue Oy is widely recognised as a manufacturer of high-quality power distribution boards. All operations are conducted in compliance with the ISO 9001:2008 quality management system. The Kuopio facility has been certified by SGS. (E Avenue Oy, 2015)

2.3.1 ISO 14001

Environmental values are also duly taken into account. E Avenue has an ISO 14001:2001-compliant environment system in place. The Kuopio facility has been certified by SGS. (E Avenue Oy, 2015)

2.3.2 PYR-Label

The recovery of packaging materials is taken care of through an agreement concluded with the Environmental Register of Packaging PYR Ltd. (E Avenue Oy, 2015)

2.3.3 Reliable partner

The fulfilment of all statutory social obligations is self-evident. E Avenue Oy participates in the Reliable Partner programme maintained by Suomen Tilajavastuu Oy. (E Avenue Oy, 2015)

3 STANDARDS

All switchgears build by E Avenue Oy comply with the Finnish standard organisation SFS (Suomen Standardisoimisliitto SFS ry. Figure 1 shows an example label of a switchgear with its standard certification.

SFS is a member of the International Organization for Standardization (ISO) and the European Committee for Standardization (CEN). The majority of SFS standards are based on international or European standards. (SFS, 2016)

In Finland standards are published often as a bilingual print in English and Finnish. For example, SFS-EN 61439. These standards comply with the International Electrotechnical Commission (IEC) therefore this paper refers to IEC standards as well as SFS-EN standards.

Määräykset, koestukset ja standardit

■ Jakokeskukset	SFS-EN 61439-1:2011 SFS-EN 61439-2:2011 SFS-EN61439-3:2012
■ Kotelointi	EN 62208
■ Pienjännitesähköasennukset	SFS 6000:2012
■ Valokaarioikosulkukestoisuus testattu	50 kA, 725 V, 0,3 s.
■ LVD	2006/95/EY
■ Muut	Vaihtosähköenergian mittaus SFS 2529:2012 Sähköenergiamittareiden tilat SFS 5601:2012



FIGURE 1. Switchgear certifications. (E Avenue Oy, 2015)

3.1 Switchgear manufacturing demanded standards

“Switchgear short-circuit current withstands are described in the IEC 61439-1 Low-voltage switchgear and controlgear assemblies - Part 1: General rules. This part of the IEC 61439 series lays down the definitions and states the service conditions, construction requirements, technical characteristics and verification requirements for low-voltage switchgear and controlgear assemblies. This standard cannot be used alone to specify an assembly or used for a purpose of determining conformity. ASSEMBLIES shall comply with the relevant part of the IEC 61439 series; Parts 2 onwards. This standard applies to low-voltage switchgear and controlgear assemblies only when required by the relevant assembly standard as follows:” (IEC61439-1, 2009, p. 12)

- “assemblies for which the rated voltage does not exceed 1 000 V in case of a.c. or 1500 V in case of d.c.;
- stationary or movable assemblies with or without enclosure;
- assemblies intended for use in connection with the generation, transmission, distribution and conversion of electric energy, and for the control of electric energy consuming equipment;
- assemblies designed for use under special service conditions, for example in ships and in rail vehicles provided that the other relevant specific requirements are complied with;
- NOTE: 2 Supplementary requirements for assemblies in ships are covered by IEC 60092-302.
- assemblies designed for electrical equipment of machines provided that the other relevant specific requirements are complied with.
- NOTE: 3 Supplementary requirements for assemblies forming part of a machine are covered by the IEC 60204 series.” (IEC61439-1, 2009, p. 12)

“This standard applies to all assemblies whether they are designed, manufactured and verified on a one-off basis or fully standardised and manufactured in quantity. The manufacture and/or assembly may be carried out by other than by the original manufacturer. This standard does not apply to individual devices and self-contained components, such as motor starters, fuse switches, electronic equipment, etc. which will comply with the relevant product standards.” (IEC61439-1, 2009, p. 12)

The IEC 61439 series, is structured into following parts:

- IEC 61439-1: General rules
- IEC 61439-2: Power switchgear and controlgear assemblies
- IEC 61439-3: Distribution boards
- IEC 61439-4: Assemblies for construction sites
- IEC 61439-5: Assemblies for power distribution
- IEC 61439-6: Busbar trunking systems

Short-circuit calculation for three phase electrical systems are defined in the standard series IEC-60909-0, 60909-1, 60909-2, 60909-3 and 60909-4. These different parts are listed below.

“IEC 60909-0, Short-circuit currents in three-phase a.c. systems – Part 0: Calculation of currents is applicable to the calculation of short-circuit currents in low-voltage three-phase a.c. systems and in high-voltage three-phase a.c. systems operating at a nominal frequency of 50 Hz or 60 Hz.” (IEC60909-0, 2001, p. 13)

“IEC TR 60909-1, Short-circuit currents in three-phase a.c. systems – Part 1: Factors for the calculation of short-circuit currents according to IEC 60909-0. This technical report aims at showing the origin and the application, as far as necessary, of the factors used to meet the demands of technical precision and simplicity when calculating short-circuit currents according to IEC 60909-0.” (IEC60909-1, 2002, p. 15)

"IEC TR 60909-2, Short-circuit currents in three-phase a.c. systems - Part 2: Data of electrical equipment for short-circuit current calculations. IEC 60909-2 comprises data of electrical equipment collected from different countries to be used when necessary for the calculation of short-circuit currents in accordance with IEC 60909-0." (IEC60909-2, 2008, p. 6)

"IEC 60909-3:2009/COR1:2013, Corrigendum 1 - Short-circuit currents in three-phase AC systems - Part 3: Currents during two separate simultaneous line-to-earth short circuits and partial short-circuit currents flowing through earth." (IEC60909-3, 2009)

"IEC/TR 60909-4:2000, Short-circuit currents in three-phase a.c. systems - Part 4: Examples for the calculation of short-circuit currents This part of IEC 60909 is a technical report intended to give help for the application of IEC 60909-0 for the calculation of short-circuit currents in 50 Hz or 60 Hz three-phase a.c. systems." (IEC60909-4, 2000, p. 11)

"IEC 60865-1, Short-circuit currents – Calculation of effects – Part 1: Definitions and calculation methods. This International Standard is applicable to the mechanical and thermal effects of short-circuit currents. It contains standardized procedures for the calculation of the effects of the short-circuit currents in two sections as follows: – Section 2 - The electromagnetic effect on rigid conductors and flexible conductors. - Section 3 - The thermal effect on bare conductors and electrical equipment." (IEC60865-1, 1993, p. 9)

3.2 Switchgear appearing current ratings

3.2.1 Rated current (I_n)

The rated current is "the current value declared by the assembly manufacturer taking into consideration the ratings of the components, their disposition and application, which can be carried without the temperature-rise of various parts of the assembly exceeding specified limits under specified conditions." (IEC61439-1, 2009, s. 26)

3.2.2 Rated current of the assembly (I_{nA})

The rated current of the assembly is "the smaller of the sum of the rated currents of the incoming circuits within the assembly operated in parallel and the total current which the main busbar is capable of distributing in the particular assembly arrangement." (IEC61439-1, 2009, p. 29)

3.2.3 Rated current of a circuit (I_{nc})

The rated current of a circuit is "stated by the assembly manufacturer, taking into consideration the ratings of the devices within the circuit, their disposition and application. This current shall be carried without the temperature rise of the various parts of the assembly exceeding the limits specified in IEC 61439-1 § 9.2. when the circuit is loaded alone." (IEC61439-1, 2009, p. 30)

3.2.4 Rated peak withstand current (I_{pk})

The rated peak withstand current is the "peak value of the short-circuit current, declared by the assembly manufacturer, that can be withstood under specified conditions. The rated peak withstand current shall be equal to or higher than the values stated for the peak value of the prospective short-circuit current of the supply system(s) to which the circuit(s) is (are) designed to be connected." (IEC61439-1, 2009, p. 30)

3.2.5 Rated short-time withstand current (I_{cw}) (of a circuit of an assembly)

The rated short-time withstand current is "the r.m.s value of short-time current, declared by the assembly manufacturer that can be carried without damage under specified conditions, defined in terms of a current and time. The rated short-time withstand current shall be equal to or higher than the prospective r.m.s. value of the short-circuit current at each point of connection to the supply. Different values of I_{cw} for different durations (e.g. 0,2 s; 1 s; 3 s) may be assigned to an assembly. For a.c., the value of the current is the r.m.s. value of the a.c. component." (IEC61439-1, 2009, p. 30)

3.2.6 Rated conditional short-circuit current of an assembly (I_{cc})

The rated conditional short-circuit current of an assembly is "the value of the prospective short-circuit current, declared by the assembly manufacturer, that can be withstood for the total operating time (clearing time) of the short-circuit protective device (SCPD) under specified conditions. The rated conditional short-circuit current shall be equal to or higher than the prospective r.m.s. value of short-circuit current (I_{cp}) for a duration limited by the operation of the short-circuit protective device that protects the assembly." (IEC61439-1, 2009, p. 30)

3.2.7 Rated diversity factor (RDF)

The rated diversity factor is the "per unit value of the rated current, assigned by the assembly manufacturer, to which outgoing circuits of an assembly can be continuously and simultaneously loaded taking into account the mutual thermal influences." (IEC61439-1, 2009, p. 30)

3.2.8 Cut-off current I_D

“The cut-off current is the largest instantaneous value of the current that a current limiting short-circuit protective device allows through. As the action of the force of the electrical current is proportional to the square of the current, the cut-off current is critical in ensuring the required mechanical strength of connected electrical equipment. This is particularly relevant for the design of bus systems (number and strength of the supports). IEC 60439 takes this circumstance into account by dispensing from the requirement of verification of the short-circuit withstand capacity for cut-off currents ≤ 17 kA.” (Rockwell Automation, 2016)

3.2.9 Joule integral I^2t

“The I^2t -value is a measure of the thermal loading of the electrical equipment in the shorted circuit. Fuses and current limiting circuit breakers limit the short-circuit current to values significantly below those of the uninfluenced current and thus reduce the thermal loading of the devices in the shorted circuit, for example of the contact system of a contactor connected downstream. The rule of thumb is that the joule integral of the short-circuit protective device must be smaller than the permissible I^2t -value of the conductor and of the electrical equipment to be protected.” (Rockwell Automation, 2016)

4 SHORT-CIRCUIT - THEORETICAL BACKGROUND

According to IEC 60909 'Short-circuit currents in three-phase a.c. systems' the definition of short circuit is an "accidental or intentional conductive path between two or more conductive parts forcing the electric potential differences between these conductive parts to be equal or close to zero." (IEC60909-0, 2001, p. 17)

Like the calculation for the load power of a circuit, the calculation of the short-circuit current is very important when planning electrical distribution networks. Short-circuits can occur because of isolation faults like an insulation breakdown, aging of the insulation material or continual stress on the insulating materials. The currents occurring during short circuits are usually repeatedly higher than the rated currents for which a particular network was designed. These short-circuit currents evoke the strongest strains in resources. Therefore, all components in a network must be able to withstand these kind of faults so that they are not damaged by the short-circuit currents. Hereby it is important to take into account the amounts of short-circuit currents and also the heat generated in the ohmic resistances. The requirement for a safe and economical design is the most accurate knowledge of the temporal current curves in the event of an error, because only then the proper security measures can be taken, namely the right choice of overcurrent protection devices which are used in case of failure of the automatic shutoff of the power supply.

4.1 Different types of short-circuit

Various types of short-circuits can occur in an electrical installation. These types of different short-circuits can be divided into four categories. These different short-circuit currents are presented in Figure 2.

- Phase-to-earth short-circuit, which occurs in 80% of faults
- Phase-to-phase short-circuit, which occurs in 15% of faults. This type of fault often degenerates into a three phase short-circuit fault
- Three-phase short-circuit, which made up 5% of initial faults (Schneider Electric, 2009, p. 6)

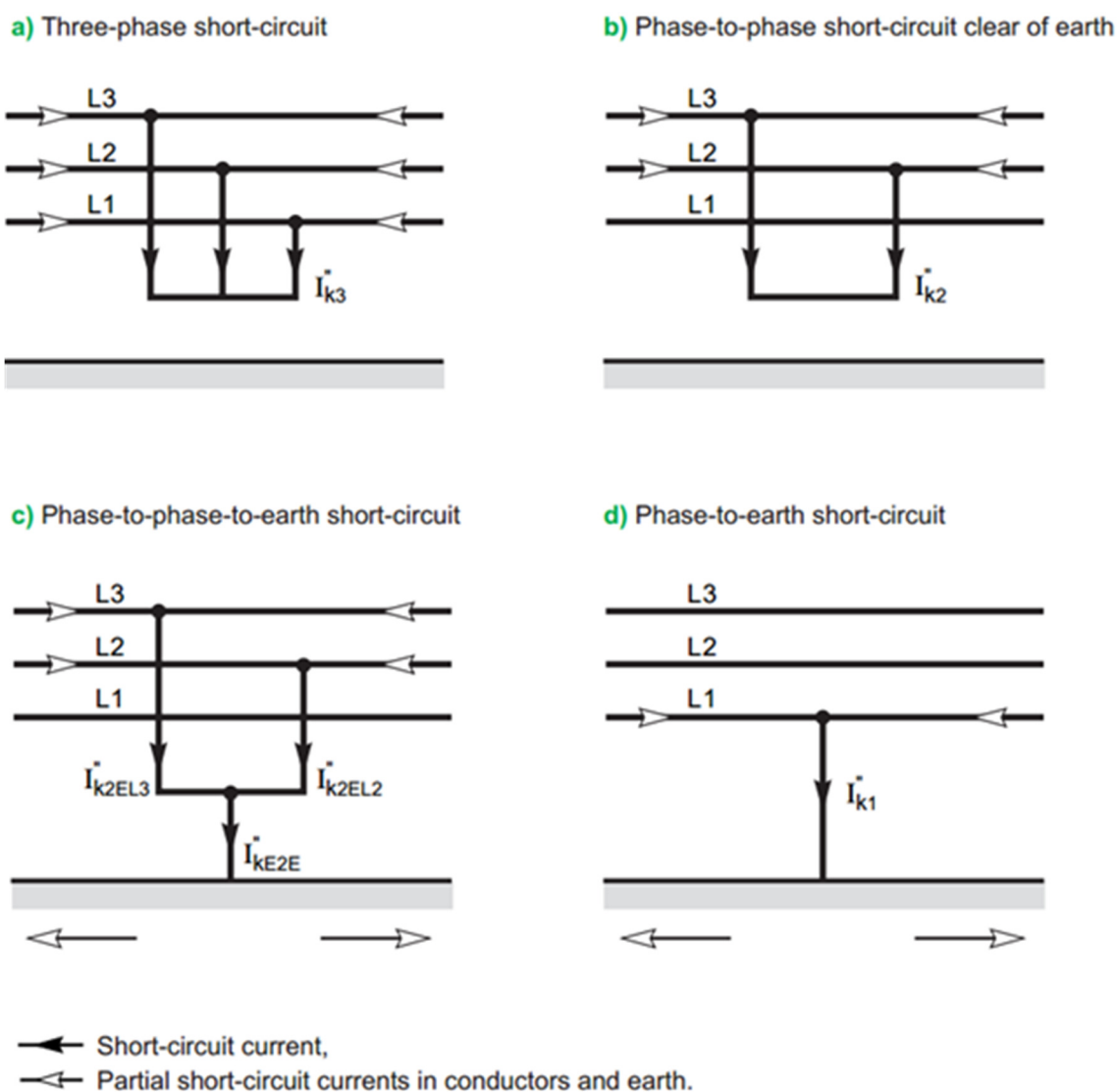

FIGURE 2. Different types of short circuit and their currents. (Schneider Electric, 2009, p. 6)

4.2 Development of the short-circuit currents

A simplified network comprises a source of constant AC power, a switch, an impedance Z_k that represents all the impedances upstream of the switch, and a load impedance (see Figure 3).

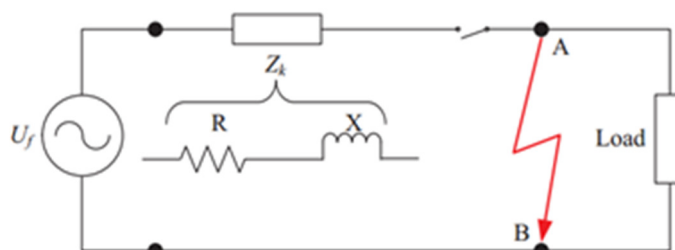

FIGURE 3. Simplified network diagram. (Alam & Saif, 2014, p. 9)

When a fault occurs between A and B, the impedance between these points results in a very high short-circuit current I_k that is limited only by impedance Z_k . The current I_k develops under transient conditions depending on the reactances X and the resistances R that make up impedance Z_k .

$$Z_k = \sqrt{R^2 + X^2} \quad (1)$$

In power distribution networks, reactance X is normally much greater than resistance R and the R/X ratio is between 0.1 and 0.3 (see Figure 9). The ratio is virtually equal to $\cos \varphi$ for low values:

$$\cos \varphi = \frac{R}{\sqrt{R^2 + X^2}} \quad (2)$$

However, the transient conditions prevailing while the short-circuit current develops differ depending on the distance between the fault location and the generator. This distance is not necessarily physical, but means that the generator impedances are less than the impedance of the elements between the generator and the fault location. (Schneider Electric, 2009)

4.3 Characteristics of short-circuit currents

A complete calculation of short-circuit currents should give the currents as a function of time at the short-circuit location from the initiation of the short circuit up to its end, corresponding to the instantaneous value of the voltage at the beginning of the short circuit (Figure 4 and Figure 5). (IEC60909-0, 2001, p. 31)

As mentioned above, while observing the characteristic of the short-circuit currents a distinction has to be made between the fault far from the generator and the fault near the generator. Figure 4 shows the schematic diagram of a short-circuit current far from the generator, which is the most frequent situation. Throughout the course of a short circuit the voltage is constant and a nearly constant alternating current portion appears.

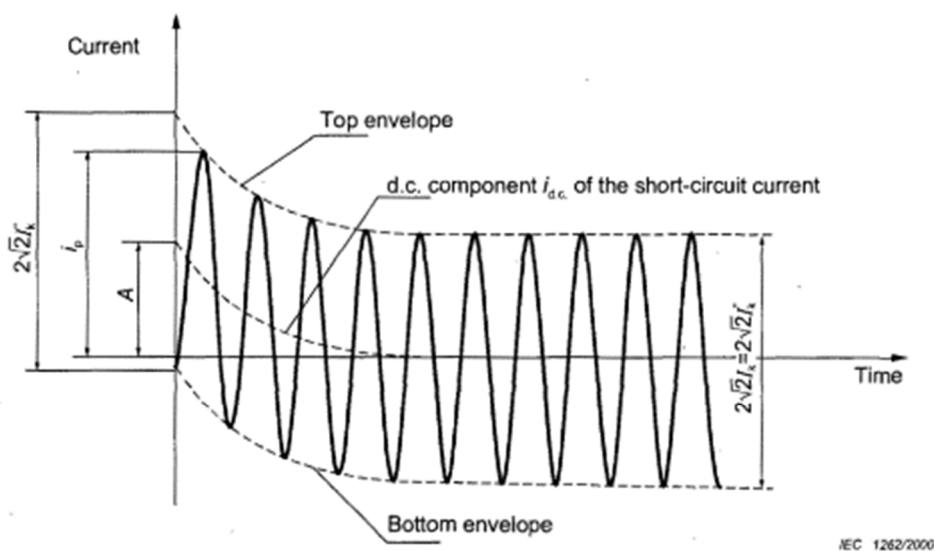

- I_k^* = initial symmetrical short-circuit current
- i_p = peak short-circuit current
- I_k = steady-state short-circuit current
- $i_{d.c.}$ = d.c. component of short-circuit current
- A = initial value of the d.c. component $i_{d.c.}$

FIGURE 4. Short-circuit current of a far-from-generator short circuit with constant a.c. component. (IEC60909-0, 2001, p. 31)

If the fault is near the generator the voltage and / or the alternating current are decaying during the short-circuit course (Figure 5).

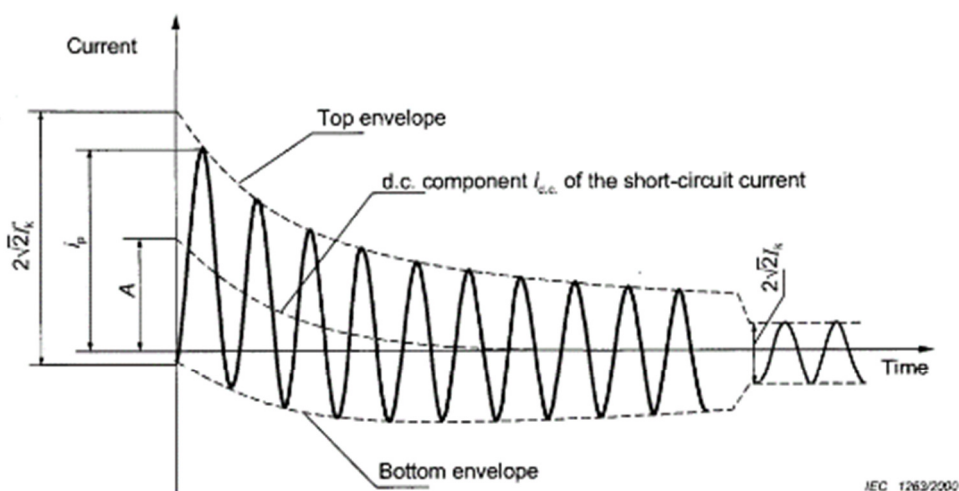

- I_k^* = initial symmetrical short-circuit current
- i_p = peak short-circuit current
- I_k = steady-state short-circuit current
- $i_{d.c.}$ = d.c. component of short-circuit current
- A = initial value of the d.c. component $i_{d.c.}$

FIGURE 5. Short-circuit current of a near-to-generator short circuit with constant a.c. component. (IEC60909-0, 2001, p. 33)

Since short-circuit is a dynamic process, the short circuit can be divided into multiple periods of time. The Subtransient short-circuit current I_k'' (initial symmetrical short-circuit current), subsides within 3 to 6 seconds and goes into transient short-circuit current I_k' . A few seconds later short-circuit current reaches its steady state. Therefore, it is called steady-state short circuit current I_k (see Figure 6).

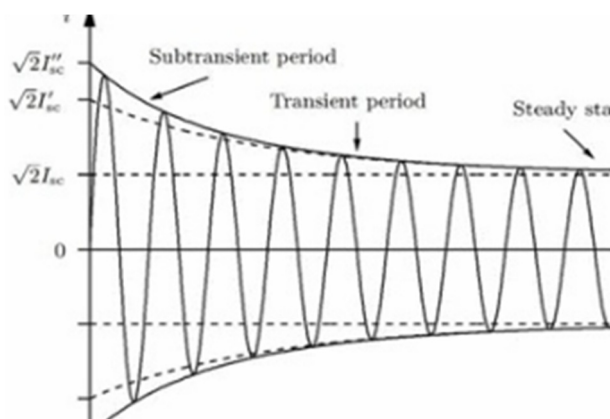

FIGURE 6. Stages of short-circuit current as function of time. (Else Engineering, 2016)

4.3.1 Maximum short-circuit current

When creating the design for the rating of equipment and what it can withstand, the main criterion is the maximum short-circuit current. It will limit the equipment as to how much thermal and electromagnetic (mechanical) effects it can resist without breaking. (Nilsson, 2010, p. 3)

Additionally, it is needed to determine the breaking and making capacity of the circuit breakers. "The maximum short-circuit current corresponds to the short-circuit in the immediate vicinity of the downstream terminals of the protection device. It must be calculated accurately and used with a safety margin." (Schneider Electric, 2009, p. 4)

"When calculating maximum short-circuit currents with IEC 60909-0 a few different conditions have to be introduced:

- A voltage factor C_{max} will be applied for the maximum calculation.
- The configuration that gives the maximum contributions from power plants and network feeders, which leads to the highest short-circuit current at the short circuit location, should be used.
- When external networks are to be represented by the equivalent impedance, the minimum equivalent impedance shall be used which corresponds to the maximum short-circuit current contribution from the feeders.
- In the most cases, motors are included in the calculations. The resistances of all the lines in the system are introduced at a temperature of 20°C." (IEC60909-0, 2001, p. 46)

4.3.2 Minimum short-circuit current

“The minimum short-circuit current is essential when selecting the time-current curve for circuit breakers and fuses, and in particular, when cables are long and/or the source impedance is relatively high (generators, UPSs). The protection of life depends on the circuit breaker or fuse operation.” (Schneider Electric, 2009, p. 4)

“When calculating minimum short-circuit currents with IEC 60909-0 a few different conditions have to be met:

- A voltage factor C_{min} is applied for the minimum calculation.
- The system configuration that leads to the minimum short-circuit current at the location of the fault has to be chosen.
- All motors can be neglected.
- Lines are introduced at a higher temperature” (IEC60909-0, 2001, p. 47)

4.3.3 Prospective short circuit current

The prospective short circuit current (PSCC) or available fault current or short circuit making current is the highest electric current which can exist in a particular electrical system under short-circuit conditions. It is determined by the voltage and impedance of the supply system.

4.3.4 Thermal equivalent short-circuit current (I_{th})

For a proper rating of power conductors and equipment the thermal effects of short-circuit currents have to be considered. In the majority of cases in practice the three phase short-circuit currents have the highest magnitudes and produce the most pronounced thermal stresses. Therefore, the impacts of such faults are usually considered as relevant for thermal sizing. (Stojanovic, 2012, p. 1)

The short-circuit currents root-mean-square value (r.m.s), or effective value, is not a constant value. Its value is changing during the short-circuit time. Therefore, a so called average effective value for the thermal short-circuit current I_{th} is set. This means that the thermal energy generated during 1 s of the effective constant short-circuit current is equal to that of the real short-circuit during the same time. In other words, the time of the short-circuit current is so short that for calculation purposes the constant effective value of the short-circuit current can be applied. The thermal equivalent short-time current is calculated from the initial short-circuit current I_k by using:

$$I_{th} = I_k \cdot \sqrt{m + n \cdot t} \quad (3)$$

The factors m and n represent the heat dissipation of the d.c. component and the a.c. component of the short-circuit current (Schlabach, 2005). Suitable ranges of values for m and n are outlined in Figure 7 and Figure 8 where T_k indicates the short-circuit duration.

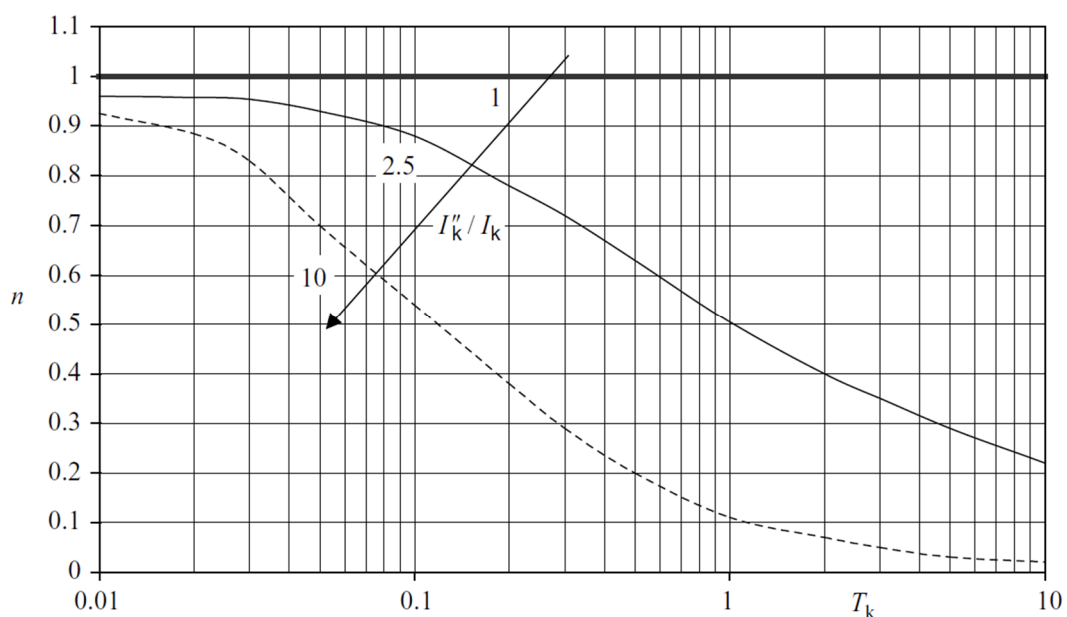

FIGURE 7. Factor n for the calculation of thermal short-time current (heat dissipation of a.c. component). (Schlabach, 2005, p. 197)

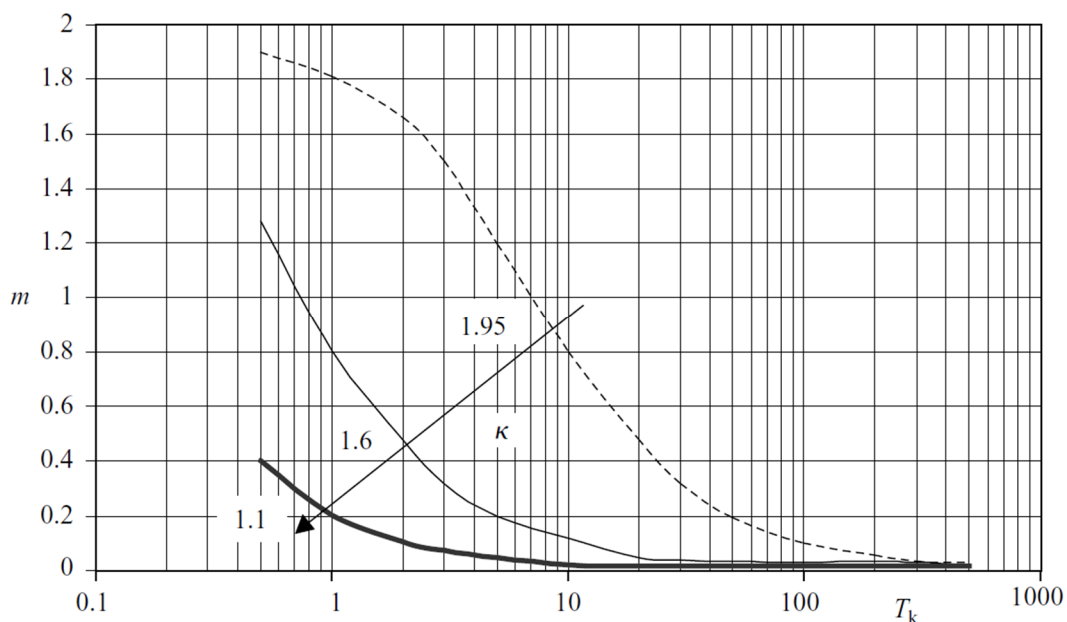

FIGURE 8. Factor m for the calculation of thermal short-time current (heat dissipation of d.c. component). (Schlabach, 2005, p. 198)

In distribution networks under 110 kV following factors for the heat dissipation apply: $m \approx 0$ and $n \approx 1$. This simplifies Equation 3 to:

$$I_{1s} = I_k'' \sqrt{t} \quad (4)$$

Where I_{1s} is the average effective short-circuit current and I_k'' is the short-circuit currents initial value, t is the short-circuit duration in seconds.

As mentioned the switchgear assembly thermal withstand, which is in principle the rated withstand current I_{cw} , is usually stated for 1 s. The short circuit-current can be also calculated for longer time intervals if it is measured for a short time and the joule integral I^2t is constant. This based on the fact that for a longer time the heat has time to move in the conductor away from the critical point. Therefore, to make calculations more practical the following Equation can be used:

$$I_{1s}^2 \cdot 1 \text{ s} = I_k''^2 \cdot t \quad (5)$$

If a switchboard has a rated short-time withstand current (I_{cw}) for a time different than 1 s it has to be indicated on the nameplate. Optionally rated short-time withstand current can be calculated for a value of 1 s.

Example:

The withstand short-circuit current of a mainboard is rated at $I_{cw} = 21 \text{ kA}$ for the time of 0,02 s. For the nameplate the value for 1 s is needed.

$$\begin{aligned} I_{1s}^2 \cdot 1 \text{ s} &= I_{cw}^2 \cdot 0,02 \text{ s} \\ I_{1s} &= I_{cw} \cdot \sqrt{0,02} = 21 \text{ kA} \cdot \sqrt{0,02} = 3 \text{ kA} \end{aligned} \quad (6)$$

"For times up to a maximum of 3 s, the relationship between the rated short-time current and the associated duration is given by the formula $I^2t = \text{constant}$, provided that the peak value does not exceed the rated peak withstand current. (IEC61439-1, 2009, s. 52)

4.3.5 Peak short-circuit current (I_p)

The largest temporary value of the short-circuit current is the peak short-circuit current. I_p has to be calculated to determine the making capacity of the required circuit breakers and to define the electrodynamic forces that the installation as a whole must be capable of withstanding. For three-phase short circuits fed from non-meshed networks the contribution to the peak short-circuit current from each branch can be expressed by Equation 7.

$$I_p = K \cdot \sqrt{2} \cdot I_k'' \quad (7)$$

where the coefficient K is indicated by the curve in Figure 9, as a function of the ratio R / X , corresponding to the expression:

$$\kappa = 1,02 + 0,98 \cdot e^{\frac{-3 \cdot R}{X}} \quad (8)$$

where

R = short-circuit resistance

X = short-circuit reactance

For low voltage networks it can be assumed that $\kappa = 1,44$ which leads to Equation 9

$$I_p \approx 2 \cdot I_k'' \quad (9)$$

This maximum instantaneous value must be used when calculating the mechanic forces of the short-circuit current.

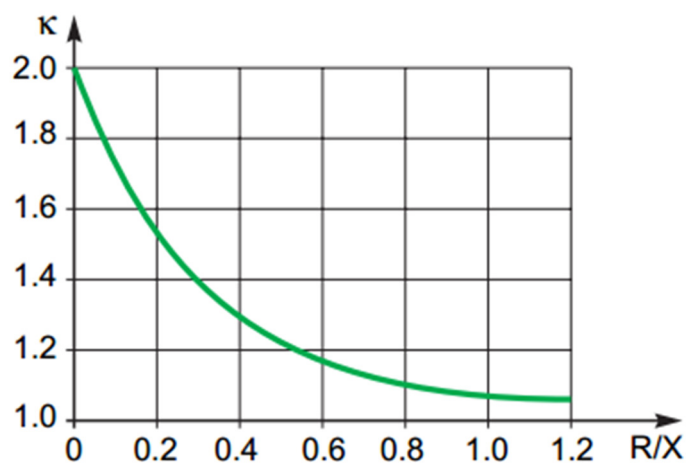

FIGURE 9. Variation of coefficient κ depending on R / X . (Schneider Electric, 2009, p. 8)

5 CALCULATIONS

5.1 One-phase short-circuit current calculation

The short-circuit current can be determined by the one-phase short-circuit current calculation method. This value is important when determining the circuit breaker and for designing selectivity. Hereby it must be distinguished between the minimum short-circuit current and the maximum short-circuit current depending on the voltage factor c . In low voltage systems, where the voltage is between 100 V and 1000 V AC, the voltage factor c for the minimum short-circuit is 0,95 and for the maximum short-circuit the voltage factor c is 1,05 (see Table 1).

In Finland, providing the network is a grounded low-voltage network, the one-phase short-circuit current is calculated for the minimum short-circuit current. Since the fuse or circuit breaker have to interrupt the circuit at the minimal possible short-circuit current in order to protect the following components properly. For the calculation the following formula is used:

$$I_{k1} = \frac{0,95 \cdot 3 \cdot U_v}{\sqrt{(2R_m + R_{m0} + 3l(r_j + r_0))^2 + (2X_m + X_{m0} + l(2x_j + x_{j0} + 3x_0))^2}} \quad (10)$$

where

U_v = phase voltage

R_m = transformer short-circuit resistance

R_{m0} = transformer neutral resistance

r_j = phase conductor resistance

r_0 = neutral conductor resistance

X_m = transformer short-circuit reactance

X_{m0} = transformer neutral reactance

x_j = phase conductor reactance

x_{j0} = phase conductor neutral reactance

x_0 = neutral conductor reactance

l = conductor length

0,95 = voltage factor c (minimum short-circuit)

5.2 Standardised short-circuit current calculations

"The calculation of the short-circuit current involves the representation of the entire power system impedances from the point of the short-circuit back to and including the source(s) of the short-circuit current. The value of the impedance depends on the short-circuit ratings for the devices or equipment under consideration." (Alam & Saif, 2014, p. 10)

“After all the components in the fault loop are represented with their corresponding impedance, the actual short-circuit computation is very simple. The standards propose a number of methods. The application guide C 15-105, which supplements NF C 15-100 (Normes Françaises) (low-voltage AC installations), details three methods.” (Alam & Saif, 2014, p. 10)

- 1) The Impedance Method
- 2) The Composition Method
- 3) The Conventional Method

For the purpose of this study only the first two Methods are considered.

“To simplify the short-circuit calculations, a number of assumptions are required. These impose limits for which the calculations are valid but usually provide good approximations the facilitating comprehension of the physical phenomena and consequently the short-circuit current calculations. They nevertheless maintain a fully acceptable level of accuracy, “erring” systematically on the conservative side. The assumptions used in this document are as follows:” (Schneider Electric, 2009, p. 11)

- “The given network is radial with nominal voltages ranging from LV to HV, but not exceeding 550 kV, the limit set by standard IEC 60909
- The short-circuit current, during a three-phase short-circuit, is assumed to occur simultaneously on all three phases
- During the short-circuit, the number of phases involved does not change, i.e. a three-phase fault remains three-phase and a phase-to-earth fault remains phase-to-earth
- For the entire duration of the short-circuit, the voltages responsible for the flow of the current and the short-circuit impedance do not change significantly
- Transformer regulators or tap-changers are assumed to be set to a main position (if the short-circuit occurs away far from the generator, the actual position of the transformer regulator or tap-changers does not need to be taken into account
- Arc resistances are not taken into account
- All line capacitances are neglected
- Load currents are neglected
- All zero-sequence impedances are taken into account” (Schneider Electric, 2009, p. 11)

5.3 Calculation of short-circuit current by the impedance method

The impedance method, reserved primarily for LV networks, was selected for its high degree of accuracy and its instructive value, given that virtually all characteristics of the circuit are taken into account.” (Schneider Electric, 2009, p. 11)

The calculation of the three- phase short-circuit current requires only the calculation of Z_k , the impedance equal to all the impedances through which I_k flows from the generator to the location of the fault, i.e. the impedances of the power sources and the lines. (Schneider Electric, 2009, p. 12)

The initial symmetrical three-phase short-circuit current I_k'' can be calculated using Equation 11 with the equivalent voltage source $cU_n/\sqrt{3}$ at the short-circuit location and the short-circuit impedance $\underline{Z}_k=R_k+jX_k$

$$I_k'' = \frac{cU_n}{\sqrt{3}Z_k} = \frac{cU_n}{\sqrt{3} \cdot \sqrt{R_k^2 + X_k^2}} \quad (11)$$

where

c = voltage factor according to IEC 60909-0 (Table 1)

U_n = supplying network voltage (equivalent voltage source)

Z_k = short-circuit impedance at short-circuit location

The short-circuit impedance (Z_k) at fault location is stated at Equation 12

$$Z_k = \sqrt{(R_k + R_{ki})^2 + (X_k + X_{ki})^2} \quad (12)$$

where

R_k = supplying network and transformer short-circuit resistance

X_k = supplying network and transformer short-circuit reactance

R_{ki} = conductor resistance from supply point to fault point

X_{ki} = conductor reactance from supply point to fault point

Table 1. Voltage factor c according to IEC 60909-0. (Schlabach 2005, 71)

Nominal system voltage U_n	Voltage factor c for calculation of	
	Maximal s.-c. current c_{\max}	Minimal s.-c. current c_{\min}
LV: 100 V up to 1000 V (inclusive) (IEC 60038, Table I)		
Voltage tolerance +6%	1.05	0.95
Voltage tolerance +10%	1.10	0.95
MV: >1 kV up to 35 kV (inclusive) (IEC 60038, Table III)	1.10	1.00
HV: >35 kV (IEC 60038, Table IV)	1.10	1.00

Remark: $c_{\max}U_n$ shall not exceed the highest voltage of equipment U_m as per IEC 60071.

5.4 Calculating short-circuit current using the "composition method"

"The "composition method" is used when the characteristics of the power supply are not known. The upstream impedance of the given circuit is calculated on the basis of an estimate of the short-circuit current at its origin. Power factor $\cos \varphi = R/X$ is assumed to be identical at the origin of the circuit and the fault location. In other words, it is assumed that the elementary impedances of two successive sections in the installation are sufficiently similar in their characteristics to justify the replacement of vector addition of the impedances by algebraic addition. This approximation may be used to calculate the value of the short-circuit current modulus with sufficient accuracy for the addition of a circuit." (Alam & Saif, 2014, p. 13)

The short-circuit power is the maximum power that the network can provide to an installation during a fault. It depends directly on the network configuration and the impedance of its components through which the short-circuit current passes. The short-circuit power S_k , in a fault point (or an assumed fault point) can be calculated by: (Alam & Saif, 2014, p. 13)

$$S_k = \sqrt{3} \cdot U \cdot I_k \quad (13)$$

where U = normal line voltage before the short-circuit occurs and I_k = the short-circuit current when the fault has occurred. This means that the short-circuit power implies that S_k is invariable at a given point in the system regardless of the voltage. The advantage with this concept is that it is a mathematical quantity that makes the calculation of short-circuit currents easier. (Alam & Saif, 2014, p. 14)

The short-circuit power of a specific network part is defined as the short-circuit power that is developed in a device according to Equation 13 if the device is fed by an infinite powerful net (that is a generator with internal impedance = 0) with line voltage U , and the short-circuit occurs at the terminals of the device. Since the impedance of a given device, such as a transmission line or transformer is usually known, the following Equation applies:

$$S_k = \frac{U^2}{Z_k} \quad (14)$$

Equation 14 can calculate the part short-circuit power for a device if the impedance Z_k is known or its impedance can be calculated if the part short-circuit power is known. The process of using the "composition method" method is very similar to the "impedance method", here the vector quantity of the short-circuit power for each component in the system are calculated separately and added together to calculate the total short-circuit power S_k .

Like impedance the short-circuit power is calculated depending on their arrangement in the network. Consider the following example network as shown in Figure 10:

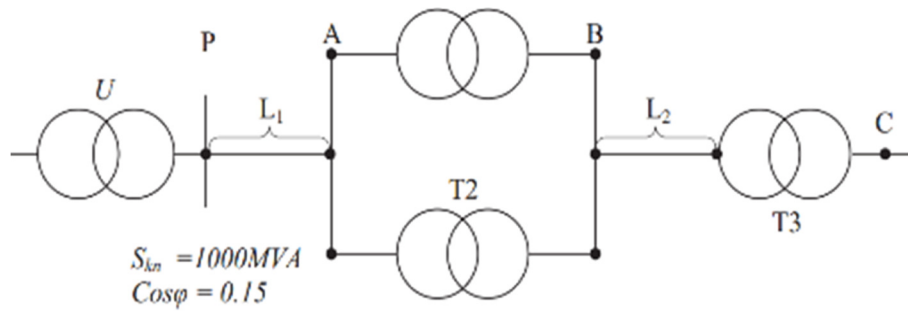

FIGURE 10. Schematic diagram of a simple transmission system. (Alam & Saif, 2014, p. 14)

The vector representation of the total short-circuit power at point P is:

$$\underline{S}_{kn} = P + jQ \quad (15)$$

where $P = S_{kn} \cdot \cos \varphi$ and $Q = S_{kn} \cdot \sin \varphi$

The different parts S_{kn} and S_{kL1} are now in series so the total short-circuit power at point A is:

$$\frac{1}{\underline{S}_{kA}} = \frac{1}{\underline{S}_{kn}} + \frac{1}{\underline{S}_{kL1}} \quad (16)$$

The total short-circuit power of the two parallel transformers T1 (S_{kT1}) and T2 (S_{kT2}) is:

$$\underline{S}_{kB} = \underline{S}_{kT1} + \underline{S}_{kT2} \quad (17)$$

The total short-circuit power at point B is:

$$\frac{1}{\underline{S}_{kB}} = \frac{1}{\underline{S}_{kA}} + \frac{1}{\underline{S}_{kT}} \quad (18)$$

again S_{kA} and S_{kT} are in series

When the short-circuit power is determined, the corresponding short-circuit current can be calculated by the following Equation:

$$I_k^n = \frac{1,1 \cdot S_k}{\sqrt{3} \cdot U_{2N}} \quad (19)$$

where 1,1 is the voltage factor c according to Table 1 for the maximum short-circuit current.

6 SHORT-CIRCUIT CURRENT LIMITING

Many large commercial and industrial electrical systems have enormous amounts of available fault current. Overcurrent devices with high enough interrupting ratings to deal with huge levels of available fault current are very expensive. It is much more practical to reduce the level of available fault current at a device, rather than buy overcurrent devices with high interrupting ratings that can handle the fault currents. (JADE Learning, 2016)

Depending on the power factor and when the fault occurs, the maximum possible instantaneous peak current without current limitation can be 2.3 times the available r.m.s. fault current when the fault occurs. As shown in Figure 11, "if a current limiting fuse is used, the maximum instantaneous peak current is limited to a small fraction of the peak current that could possibly flow if the fuse were not used. The current-limiting fuse link melts and clears the circuit in less than 0.0083 seconds. The area under the curve is known as the I^2t let-through energy of the fuse. The lower the I^2t is, the lower the destructive energy is that passes through the circuit before it is interrupted." (Littelfuse, 2009, p. 4)

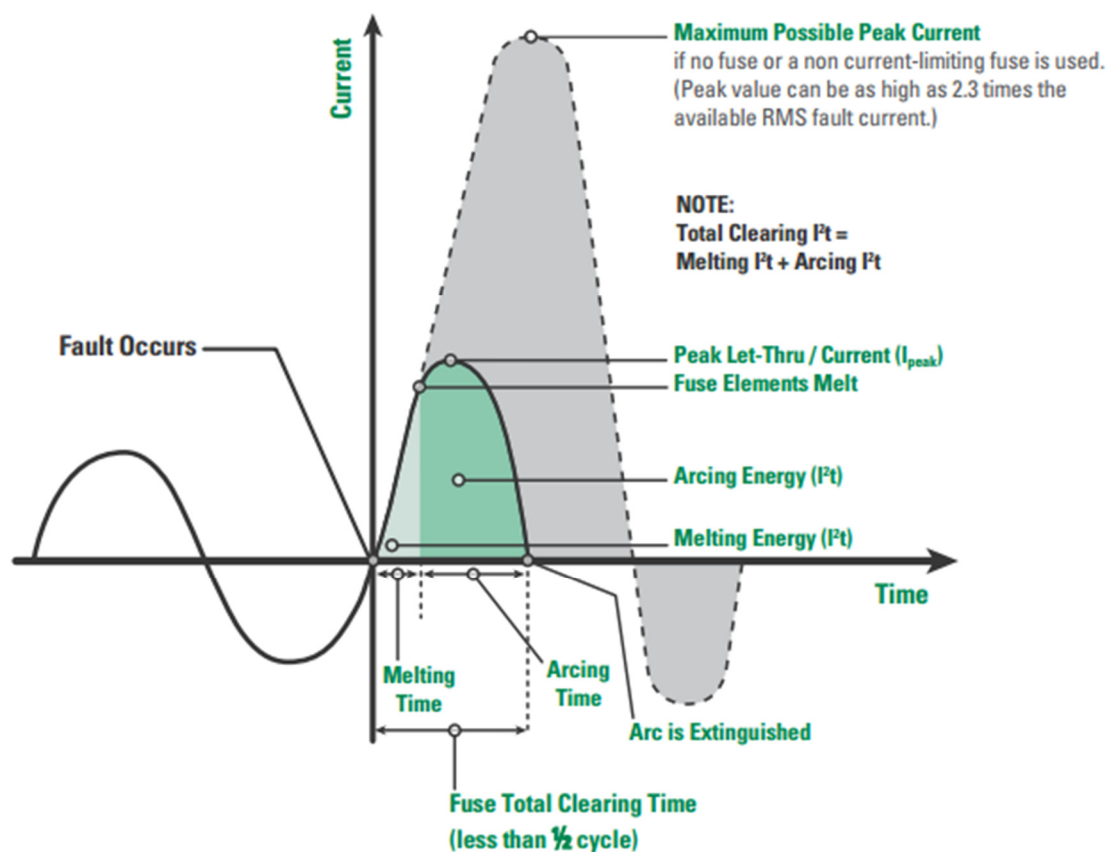

FIGURE 11. Current Limitation and Peak Let-through. (Littelfuse, 2009, p. 4)

Current limitation reduces both thermal and electrodynamic stresses on all circuit elements through which the current passes, thereby prolonging the useful life of these elements. Furthermore, the limitation feature allows "cascading" techniques to be used (Coordination between circuit-breakers) thereby significantly reducing design and installation costs. (Electrical Installation Wiki Schneider Electric, 2015)

6.1 Short-circuit current limiting circuit breaker

The current limiting circuit breaker has the ability, in case of a fault, to prevent the passage of the maximum prospective fault-current, permitting only a limited amount of current to flow, as shown in Figure 12. Loading in the event of a short-circuit is defined by the joule integral (I^2t value), the cut-off current (I_D) and the short-time current (I_{cw}).

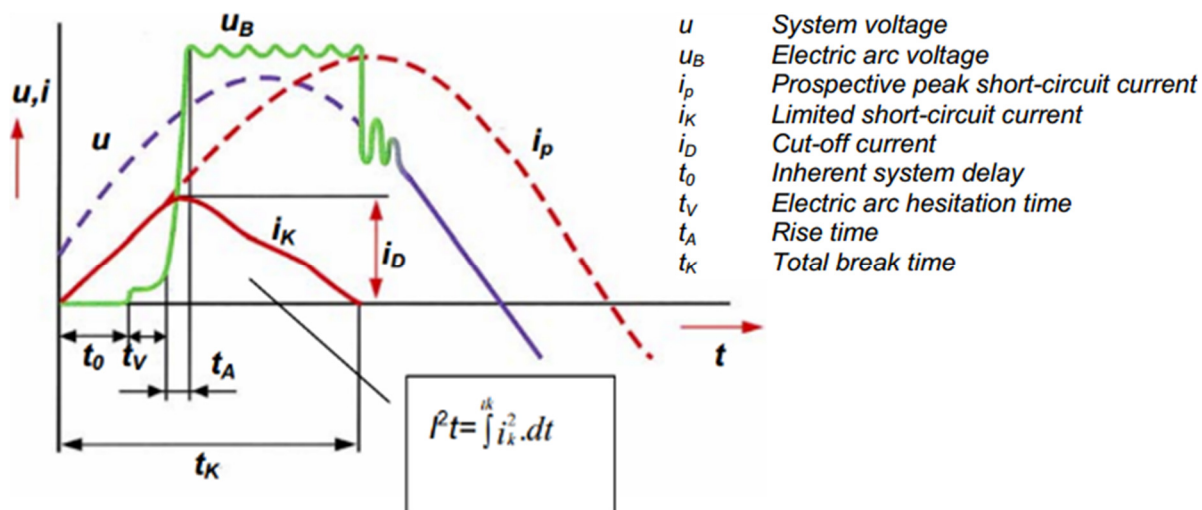

FIGURE 12. Basic characteristic of current and voltage when clearing a short-circuit with a current limiting circuit breaker. (Rockwell Automation, 2016, p. 38)

The use of current-limiting circuit breakers offers numerous advantages:

- Better conservation of installation networks: current-limiting CBs strongly attenuate all harmful effects associated with short-circuit currents
- Reduction of thermal effects: Conductors (and therefore insulation) heating is significantly reduced, so that the life of cables is correspondingly increased
- Reduction of mechanical effects: forces due to electromagnetic repulsion are lower, with less risk of deformation and possible rupture, excessive burning of contacts, etc.
- Reduction of electromagnetic-interference effects and therefore less influence on measuring instruments and associated circuits, telecommunication systems, etc. (Electrical Installation Wiki Schneider Electric, 2015)

Figure 13 shows the current limiting capability of a ABB Tmax Moulded Case Circuit Breakers.

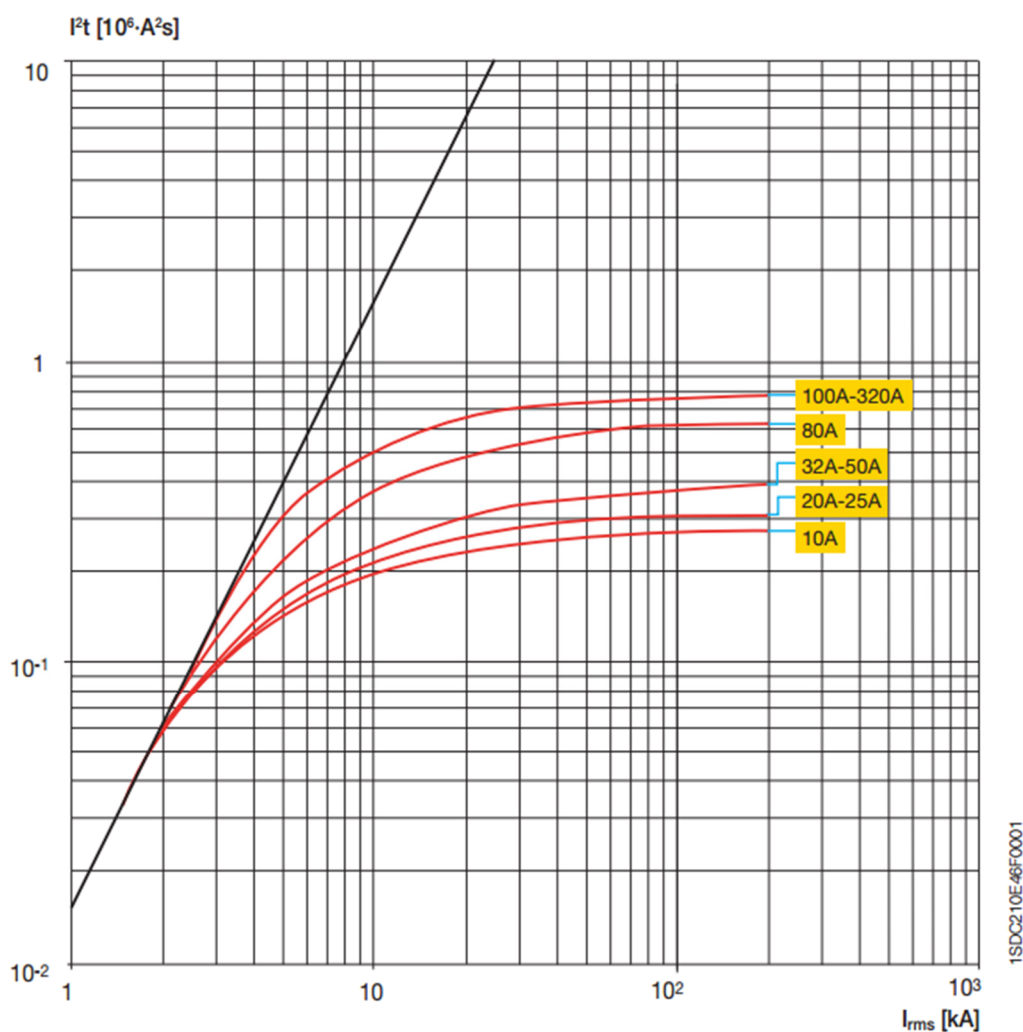

FIGURE 13. ABB T4 250/320 Let-through energy curve. (ABB, 2015, p. 153)

6.2 Short-circuit current limiting fuse

In practice, current-limiting fuses are used to protect circuits feeding transformers, motors and other equipment where overloads and inrush currents are common. The most common type of fuse in low voltage networks are the NH fuses, due to their affordability, safety, selectivity and good current limiting capability. NH stands for the German words *Niederspannung, Hochleistung* (low voltage, heavy duty). NH fuses are typically used for power distribution applications and to protect large electrical devices such as motors and drives.

NH fuses have knife blades at both ends which mount into one or three pole fuse basis/holder. The main parts of the NH fuse are the ceramic case, silica sand and the fuse element (See Figure 14). The fuses excellent current-limiting capability is based on the rapid growing arc resistance where the silica sand is limiting the arc energy arising.

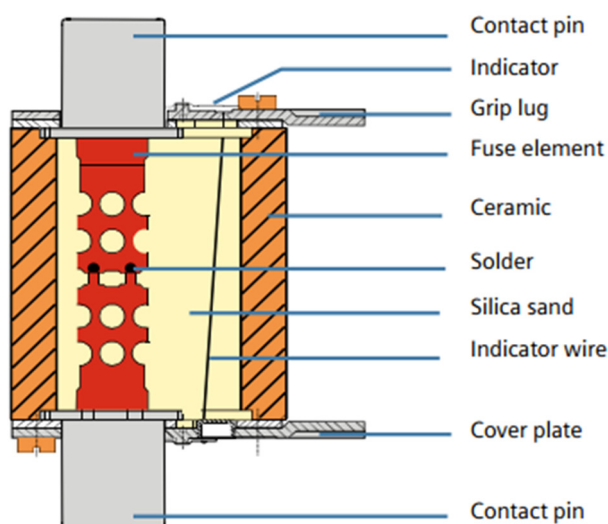

FIGURE 14. NH fuse. (Siemens, 2014, p. 19)

6.3 Current-Limiting Fuse Let-Through Charts

“The degree of current-limitation of a given size and type of fuse depends, in general, upon the available short-circuit current that can be delivered by the electrical system. The current-limitation of fuses is best described in the form of a let-through chart that, when applied from a practical point of view, is useful to determine the let-through currents when a fuse opens.” (Bussmann, 2013)

“The let-through data has been generated by actual short-circuit tests of current-limiting fuses. It is important to understand how the curves are generated, and what circuit parameters affect the let-through curve data. Typically, there are three circuit parameters that can affect fuse let-through performance for a given available short-circuit current. These are: 1. Short-circuit power factor, 2. Short-circuit closing angle and 3. Applied voltage.” (Bussmann, 2013)

“Current-limiting fuse let-through curves are generated under worst case conditions, based on these three variable parameters. The benefit to the user is a conservative resultant let-through current. Under actual field conditions, changing any one or a combination of these will result in lower let-through currents. This provides for an additional degree of reliability when applying fuses for equipment protection. Prior to using the fuse let-through charts, it must be determined what let-through data is pertinent to equipment withstand ratings. Equipment withstand ratings can be described as: How much fault current can the equipment handle, and for how long? Based on standards presently available, the most important data that can be obtained from the Fuse Let Through Charts and their physical effects are the following:” (Bussmann, 2013)

- A. Peak let-through current: mechanical forces (49 kA in Figure 15)
- B. Apparent prospective r.m.s. symmetrical let-through current: heating effect (21 kA in Figure 15)
- C. Clearing time: less than 1/2 cycle when fuse is in it's current-limiting range (beyond where fuse curve intersects A-B line in Figure 15)

“If the RMS Symmetrical available is greater than the point where the fuse characteristic curve intersects with the diagonal A-B line, then the fuse clearing time is 1 /2 cycle or less. In the example of Figure 15, the intersection is approximately 9500A; so for short-circuit currents above approximately 9500A, this KRP-C-800SP fuse is current-limiting.” (Bussmann, 2013)

Figure 15 shows the current-limitation curves of an 800 A Cooper Bussmann Low-Peak Time-Delay Fuse KRP-C-800SP.

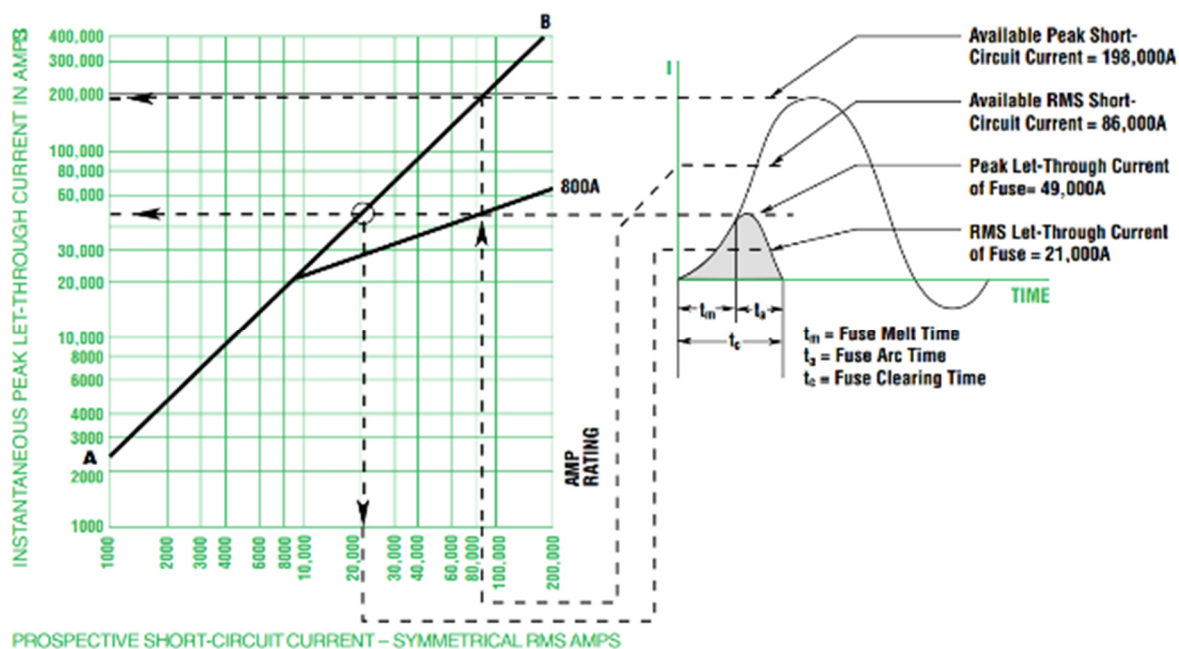

FIGURE 15. Current-limiting let-through chart for a KRP-C-800SP fuse. (Bussmann, 2013, p. 2)

6.4 Current-limiting transformers

Transformers set not only the rated current on the secondary side they can also reduce the short-circuit current based on their rated power S_N and their impedance z_k (%) and the secondary voltage. The short-circuit current (Equation 21) can be calculated from the transformer impedance and secondary voltage (Equation 20).

$$Z_k = \frac{z_k}{100} \cdot \frac{U_{2N}}{S_N} \quad (20)$$

$$I_k = \frac{U_{2N}}{\sqrt{3} \cdot Z_k} \quad (21)$$

Alternatively, calculation can be done through rated current.

$$I_N = \frac{S_N}{\sqrt{3} \cdot U_{2N}} \quad (22)$$

Hence, the short-circuit current.

$$I_k = \frac{I_N}{z_k} \quad (23)$$

Manufactures state the rated power of a transformer. Tables with default ratings for transformers are available such as the Table 2 below.

TABLE 2. Determination of the rated values of an assembly. (SFS Käsikirja 154, 2005, p. 333)

S _n / kVA	I _n / A			Z _k / %	I _{cw} / kA		
	400 V	500 V	690 V		400 V	500 V	690 V
100	140	110	80	3,8	4	3	2
200	280	220	160	4	7	6	4
315	440	350	260	4,5	10	8	6
500	700	550	410	5	14	11	8
800	1130	880	650	5,5	21	16	12
1000	1410	1100	810	5,5	26	20	15
1250	1760	1380	1020	5,5	32	25	19
1600	2250	1760	1300	5,5	41	32	24
2000	2820	2200	1630	6	47	37	27
2500	3520	2750	2030	6	59	46	34
3150	4440	3460	2560	7	63	50	37
4000			3250	7			47

6.5 Short-circuit switching capacity

The switching capacity is the r.m.s value of a current at a given power factor $\cos \varphi$ as well as a given rated voltage at which a switchgear or a fuse can still shut-off under specified conditions in an operationally safe way. Both the short-circuit making capacity as well as the short-circuit breaking capacity of circuit breakers must be larger than or equal to the prospective short-circuit current at the place of installation. If this is not the case, then a suitable backup protection (for example a fuse) should be provided to ensure the required switching capacity of the device combination. (Rockwell Automation, 2016, p. 42)

6.5.1 Rated short-circuit making capacity I_{cm}

The rated short-circuit making capacity I_{cm} is a quantity that according to regulations must be in a certain ratio to the rated ultimate short-circuit breaking capacity I_{cu} and that has to be guaranteed by the device manufacturer. This is not a variable that must be considered by the user, however, it ensures that a circuit breaker is in the position to connect onto a short-circuit – and to disconnect it subsequently. (Rockwell Automation, 2016, p. 42)

6.5.2 Rated short-circuit breaking capacity I_{cu} and I_{cs}

IEC 60947-2 makes the distinction between the rated ultimate short-circuit breaking capacity I_{cu} and the rated service short-circuit breaking capacity I_{cs} :

Rated ultimate short-circuit breaking capacity I_{cu} :

I_{cu} is the maximum breaking capacity of a circuit breaker at an associated rated operational voltage and under specified conditions. I_{cu} is expressed in kA and must be at least as large as the prospective short-circuit current at the site of installation. Circuit breakers that have switched-off at the level of the ultimate short-circuit breaking capacity, are reduced serviceable afterwards and should at least be checked regarding functionality. There may be changes in the overload trip characteristic and increased temperature rise due to the erosion of contact material. (Rockwell Automation, 2016, p. 42)

Rated service short-circuit interrupting capacity I_{cs} :

I_{cs} values are usually lower than the values for I_{cu} . Circuit breakers that have been switching-off at the level of the service short-circuit breaking capacity continue to be serviceable afterward. In plants in which interruptions to operations must be kept as short as possible, product selection should be carried-out based on I_{cs} . (Rockwell Automation, 2016, p. 43)

The same applies to fuses as to circuit breakers with respect to the I_{cu} : at the given rated operational voltage, the rated breaking capacity must be at least as large as the prospective short-circuit current at the site of installation. (Rockwell Automation, 2016, p. 43)

7 PROTECTIVE DEVICE COORDINATION

“The coordination of protective devices within the assembly with those to be used external to the assembly shall be the subject of an agreement between the assembly manufacturer and the user. Information given in the assembly manufacturer's catalogue may take the place of such an agreement.” (IEC61439-1, 2009, p. 52)

“If the operating conditions require maximum continuity of supply, the settings or selection of the short-circuit protective devices within the assembly should, where possible, be so coordinated that a short circuit occurring in any outgoing circuit is cleared by the switching device installed in the circuit without affecting the other outgoing circuits, thus ensuring selectivity of the protective system.” (IEC61439-1, 2009, p. 52)

“Where short-circuit protective devices are connected in series and are intended to operate simultaneously to reach the required short-circuit switching capability (i.e. back-up protection), the assembly Manufacturer shall inform the User (e.g. by a warning label in the assembly or in the operating instructions) that none of the protective devices are allowed to be replaced by another device which is not of identical type and rating, since the switching capability of the whole combination may otherwise be compromised.” (IEC61439-1, 2009, p. 53)

“The switching devices and components having a short-circuit withstand strength and/or a breaking capacity which is insufficient to withstand the stresses likely to occur at the place of installation, shall be protected by means of current-limiting protective devices, for example fuses or circuit-breakers. When selecting current-limiting protective devices for built-in switching devices, account shall be taken of the maximum permissible values specified by the device manufacturer, having due regard to coordination.” (IEC61439-1, 2009, p. 53)

7.1 Selectivity

Selectivity, according to IEC 60947-2, means that in the case of a fault only the overcurrent protection device closest to the fault location interrupts the current, and upstream protection devices do not trip. In this respect, there is a requirement that the time/current curves of two selectively functioning switching devices do not touch or intersect. Distinctions are made in practice between current, time and zone selectivity (signal controlled selectivity). (ABB, 2008, p. 26)

Figure 16 shows the basic schematic of selectivity.

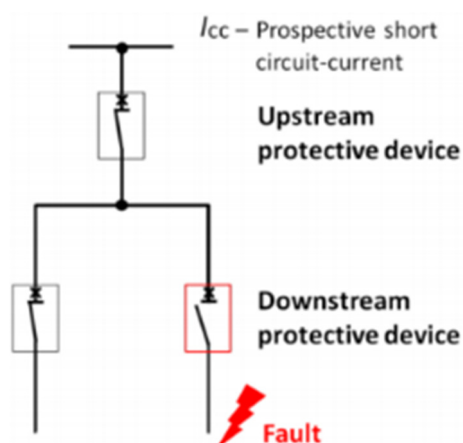

FIGURE 16. Schematic of selectivity. (Eaton, 2015, p. 12)

7.1.1 Selectivity categories

Standard IEC 60947-2 describes two categories of breakers with selectivity category A and B (see Figure 17).

- Selectivity category A** is used for breakers installed on the load side, which typically do not have any intentional short-time delay. The short-time withstand current is not taken into account.
- Selectivity category B** is specifically intended for incoming breakers (on the supply side) under short-circuit conditions. Such breakers must have the possibility of a short-time delay and also specify a minimum value short-time withstand current rating according to standard.

Selectivity is not necessarily ensured up to the ultimate short-circuit breaking capacity I_{cu} of the circuit breakers but at least up to the specified values of I_{cw} . (Eaton, 2015, p. 23)

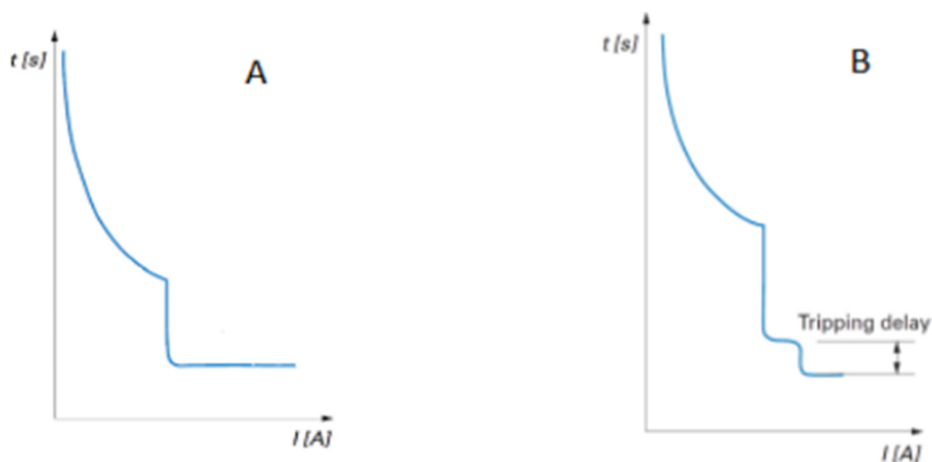

FIGURE 17. Selectivity category A and B circuit-breakers. (Eaton, 2015, p. 23)

7.1.2 Current selectivity

This type of selectivity is based on the observation that the closer the fault point is to the power supply of the installation, the higher the short-circuit current is. It is therefore possible to discriminate the zone the fault occurred in by setting the instantaneous protections to different current values. (ABB, 2015, p. 8)

An overcurrent selectivity can be divided into total or partial selectivity:

- a) **Total selectivity** (full, natural) is the optimal solution, but with respect to conditions of real installation, it can only be achieved in specific situations. Firstly, it is necessary to use protective devices with different frame sizes, tripping characteristics and also to take into account the value of the fault current at the end of installation, which should not be so high. In typical applications, it is necessary to evaluate several parameters together, which often oppose each other. Total selectivity is ensured up to the value of the short-circuit current of the installation. (Eaton, 2015, p. 12)

Figure 18 shows an example with two different frame sizes circuit breakers. Such combination ensures total selectivity up to the value of the breaking capacity I_{cu} of the downstream breaker number 2. (Eaton, 2015, p. 12)

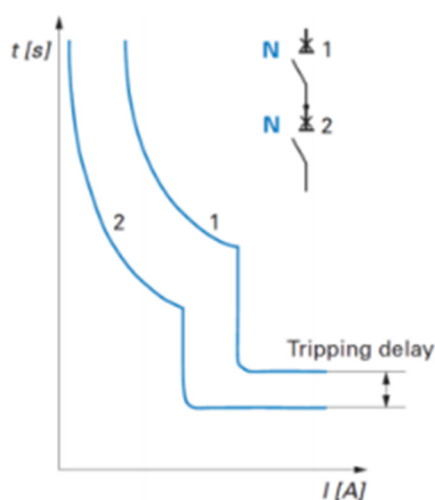

FIGURE 18. Total selectivity between two circuit breakers. (Eaton, 2015, p. 12)

- b) **Partial selectivity** between several protection devices in series is often more than enough to obtain. In all cases it is necessary to know the value of the prospective short circuit current in the respective node of the installation and to compare it with the value of the selectivity limit current I_s of the two protective devices in series. If this is fulfilled, partial selectivity is good enough to reduce unwanted trips. (Eaton, 2015, p. 12)

Figure 19 shows an example with two circuit breakers with the same frame sizes and similar tripping time.

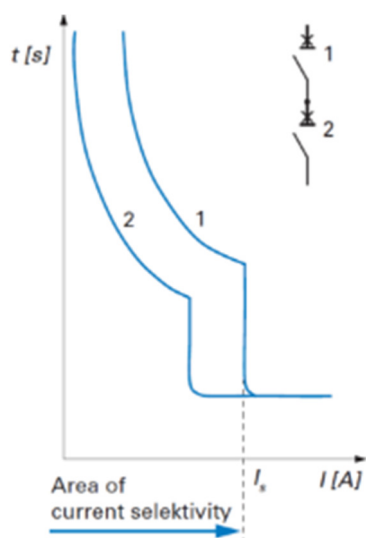

FIGURE 19. Partial selectivity up to selectivity limit current (I_s). (Eaton, 2015, p. 13)

7.1.3 Time selectivity

The protective device on the power supply side (upstream) uses a time delay t_{sd} to prevent tripping of the breaker for that specified time for currents up to the short-time delay current I_{sd} . This gives the downstream breaker the chance to clear the fault and ensure selectivity of the installation. If the fault is between the upstream and downstream breakers, respectively, the upstream breaker trips after that time delay has passed. Time selectivity can be easily applied with use of selective breakers with electronic trip units (selectivity category B) where a time delay is adjustable in exactly specified steps. (Eaton, 2015, p. 24)

Figure 20 shows an example of time selectivity. Here are two circuit breakers with the same frame size, and the upstream breaker with short time delay (selectivity category B). Such combination ensures partial selectivity.

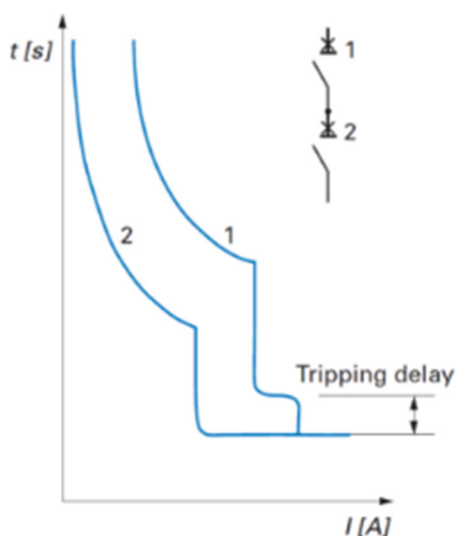

FIGURE 20. Time selectivity. (Eaton, 2015, p. 24)

7.1.4 Zone selectivity

Circuit breakers with zone sequence interlocking (ZSI) significantly reduce incident energy levels by communication between the trip units of upstream and downstream breakers. When a short-circuit current is detected, a ZSI-equipped breaker sends a signal to the upstream breaker which blocks tripping for a specified time. If the breaker itself does not receive a blocking signal it will trip according to its settings without additional delay. This ensures that always the breaker closest upstream to the fault trips and interrupts in the shortest possible time reducing let-through energy of the short-circuit current as much as possible. Wiring for ZSI is easy and straight forward using the clearly marked terminals of the trip units.

The advantage of the zone selectivity feature compared to ordinary time selectivity is significantly reduced time until switch-off and reduced amount of let-through energy released in the event of a short-circuit. (Eaton, 2015, p. 25)

Figure 21 shows a diagram of Zone Sequence Interlocking (ZSI) between circuit breakers.

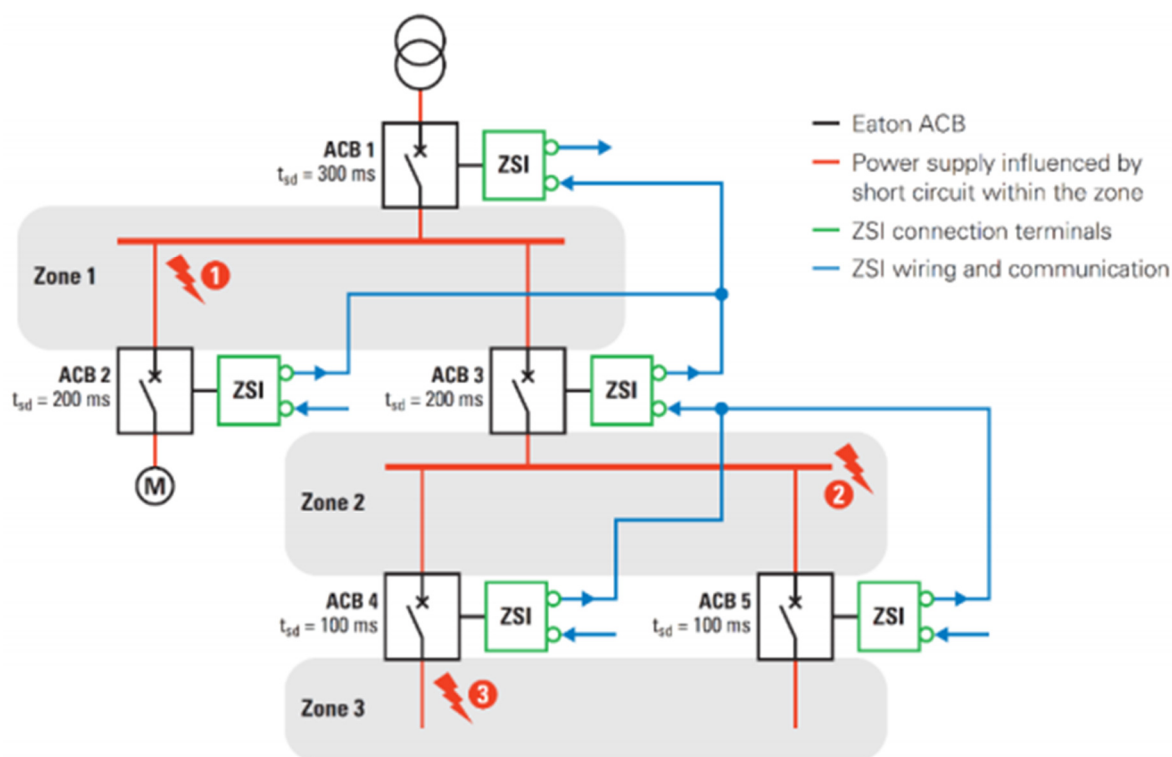

FIGURE 21. Diagram of Zone Sequence Interlocking (ZSI) between ACBs. (Eaton, 2015, p. 25)

7.1.5 Selectivity between fuses

Selectivity between fuses connected in series is achieved when the melting time of the upstream fuse is greater than the OFF time of the fuse at the fault location. Selective protection is easy to achieve with fuses because their melting time / current characteristic curves run practically parallel to each other across the entire current range and do not overlap (Figure 22). (Siemens, 2014, p. 57)

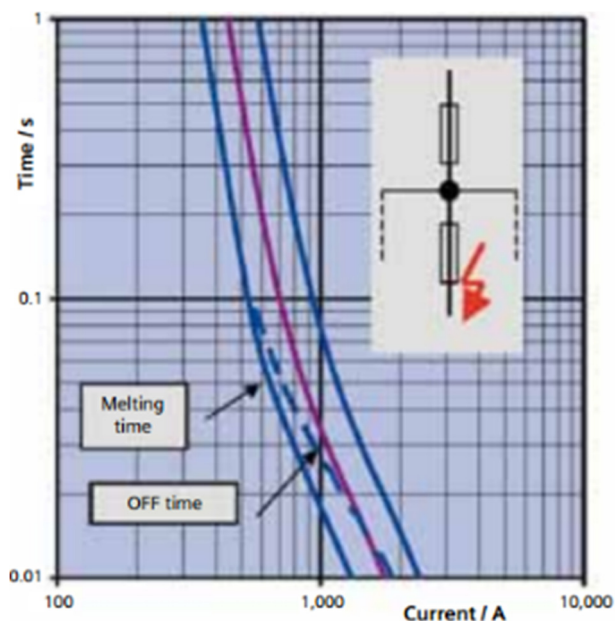

FIGURE 22. Selective protection in a radial network. (Siemens, 2014, p. 57)

7.1.6 Selectivity between fuses and circuit breakers

Like fuses, circuit breakers trip after a particular length of time depending on the current. This correlation is represented in time/current characteristic curves and enables selectivity analyses with fuses. In simple terms, the tripping curve of a circuit breaker comprises a vertical branch for the tripping current and a horizontal branch that corresponds to a constant tripping time. The fuse characteristic curve runs almost diagonally because it falls continuously in line with a constant melting integral even at very high currents. Depending on the relative position of the characteristic curves, interfaces that mark the selectivity limits can occur. (Siemens, 2014, p. 58)

Figure 23 shows two types of fuse circuit breaker combinations.

- a) An upstream fuse with downstream MCB is a typical combination used in residential installations and provides partial selectivity up to selectivity-limit current I_s (Figure 23, the right side).
- b) An upstream MCB with downstream fuse usually ensures total selectivity but this combination is not used so often (Figure 23, left side).

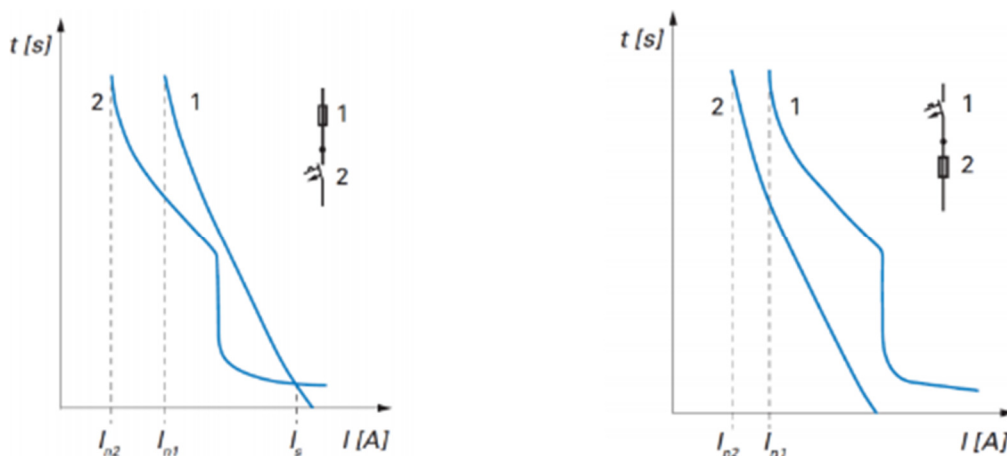

FIGURE 23. Selectivity between fuse and circuit breaker. (Eaton, 2015, p. 18)

7.1.7 Selectivity table

The selectivity behaviour of breaker combinations is given by selectivity tables and published by the manufacturer. Figure 24 gives an example how to read a selectivity table.

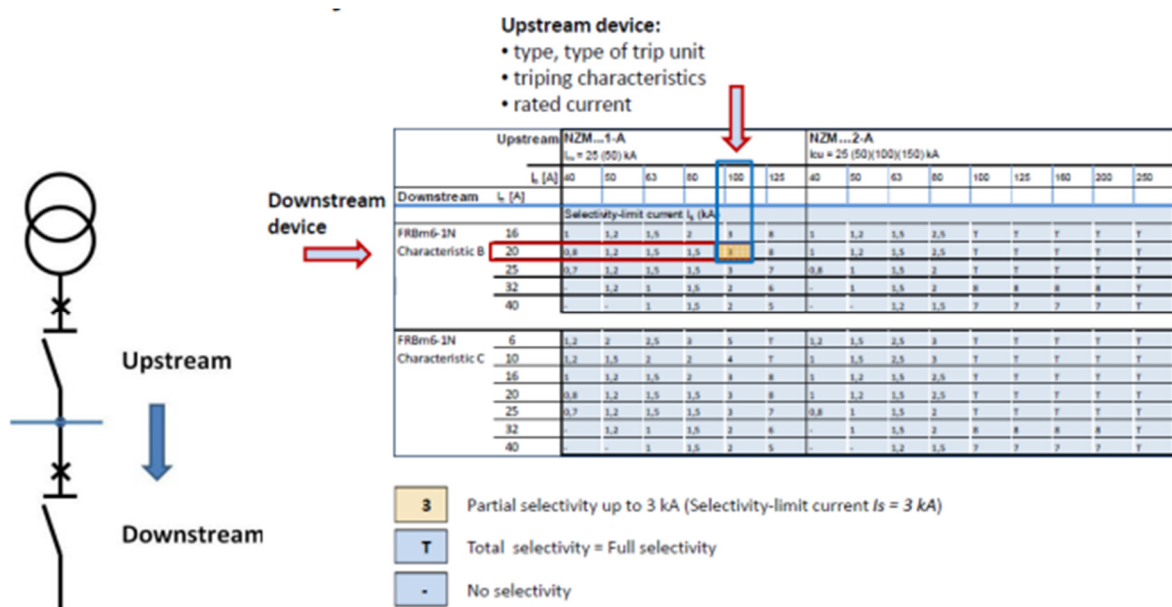

FIGURE 24. How to use selectivity tables. (Eaton, 2015, p. 26)

7.2 Backup protection

In cases where the available short-circuit current level exceeds the short-circuit rating I_{cu} of the downstream breaker a current-limiting upstream breaker can be used to ensure proper protection of the installation. The take-over current I_B of the upstream breaker, i.e. the current at which the upstream breaker starts to trip must not be larger than I_{cu} of the downstream breaker in order for that back-up protection providing breaker to ensure protection for all possible short-circuit currents.

While back-up protection enhances the protection level of the downstream breakers it can also compromise selectivity since the upstream breaker is permitted to open and disconnect its complete downstream installation. (Eaton, 2015, p. 28)

Figure 25 illustrates two examples of how to accomplish back-up protection

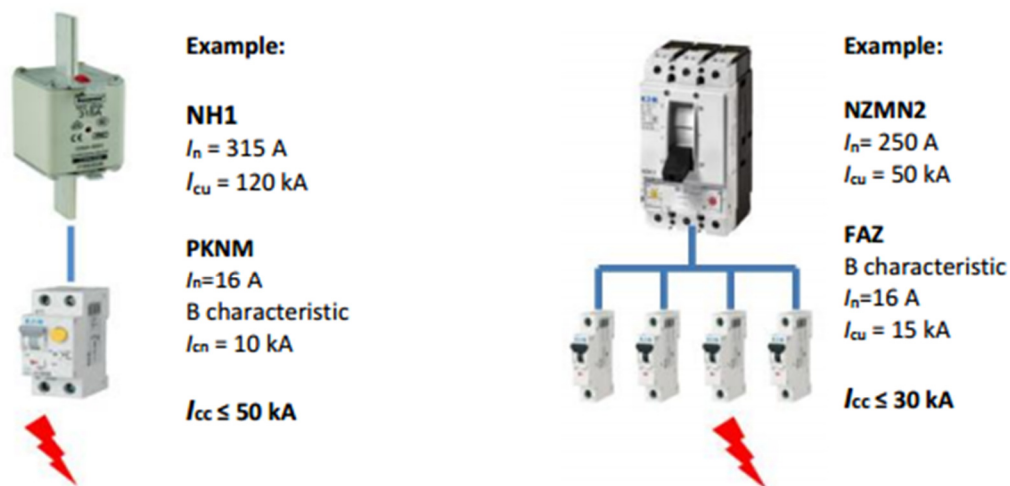

a) back-up protection of RCBOs by fuses

b) back-up protection of MCBs by MCCBs

FIGURE 25. Back-up protection with fuses and circuit breakers. (Eaton, 2015, p. 28)

A typical combination of downstream MCBs together with upstream current limiting types of MCCBs provides a very good and cost-effective solution. (Eaton, 2015, p. 28)

8 SWITCHGEAR SHORT-CIRCUIT CURRENT WITHSTAND RATING

The short-circuit withstand capacity of electrical equipment is usually defined by stating the largest permitted short-circuit protective device (for example permissible fuse or permissible circuit breaker). Current limiting fuses and modern current limiting circuit breakers make a major contribution to the economical rating of devices, as they strongly reduce the thermal and dynamic loading of devices and equipment connected downstream. (Rockwell Automation, 2016, p. 37)

8.1 Short-circuit impact on switchgear

Short-circuits stresses the switchgear mechanical through the dynamical forces of the short-circuit current at the beginning of the current fault and thermal since the high energy produced by the short-circuit power is dissipated into heat. Normally the thermal short-circuit current is not a problem. The cables and busbars are dimensioned based on the load current so that they can withstand for a short period of time the short-circuit current without a rise in temperature which would lead to destruction.

Therefore, the electrodynamic stress on the switchgear is the important factor when determining the short-circuit current withstand. The dynamic short-circuit current forces can stress the busbars and their fixations significant. They have to withstand the highest possible short-circuit current without lasting stain or break of the fixations. Especially the oscillation of the busbars can cause to break the flanges and fixations. The short-circuit current withstand of the busbars can be obtained by calculation. In addition, manufactures provide data tables for their different kind of busbars. Whereas the short-circuit current withstand of the fixations can be only stated by tests.

8.2 Short-circuit current rating (SCCR)

"Short-circuit current rating (SCCR) is the maximum short-circuit current a component or assembly can safely withstand when protected by a specific overcurrent protective device(s) or for a specified time." (Bussmann, 2013)

"Short-circuit current ratings provide the level of fault current that a component or a piece of equipment can safely withstand (based on a fire and shock hazard external to the enclosure). Without knowing the available fault current and short-circuit current rating, it is impossible to determine if components or equipment can be safely installed." (Bussmann, 2013)

Individual panel components have an SCCR or interrupting rating. The component with the lowest SCCR in the panel limits the overall panel assembly rating. This SCCR rating has to be displayed on the nameplate and is usually calculated by the manufacturer or assembler of the control panel.

The short-circuit current magnitude is determined either by computation or by measurement. For new applications, the measurement cannot be done before preparation of the switchgear, nor is it always possible to rely on measurement of older installations. The manufacturer often does not know the switchgear's future operating conditions (feeding transformer, type and length of cable network, change of conductor resistance caused by the temperature change, additional power to the grid, caused by motors, etc.)

"It is the responsibility of the consulting or electrical design engineer to verify that all industrial control panels are applied in a manner such that the panel's SCCR is greater than the system's available fault current. It is the responsibility of the industrial control panel manufacturer to provide accurate SCCR information to the consulting engineer and authority having jurisdiction through required labels and published technical information." (Littelfuse, 2009, p. 2)

8.3 Determining the rated short-time withstand current (I_{cw}) of a circuit of an assembly

The original manufacturer of the switchgear system, is responsible for the verification of the short circuit withstand capacity of the system components, e.g. the I_{cw} value of the busbars.

Rated short-circuit withstand current is determined by the values I_k'' , I_{cw} , I_{cp} , I_{cu} . (Hensel, 2015)

"A verification of the short-circuit withstand strength is not required for the following:

- 1) assemblies having a rated short-time withstand current or rated conditional short-circuit current not exceeding 10 kA r.m.s.
- 2) assemblies protected by current-limiting devices having a cut-off current not exceeding 17 kA at the maximum allowable prospective short-circuit current at the terminals of the incoming circuit of the assemblies.
- 3) Auxiliary circuits of assemblies intended to be connected to transformers whose rated power does not exceed 10 kVA for a rated secondary voltage of not less than 110 V, or 1,6 kVA for a rated secondary voltage less than 110 V, and whose short-circuit impedance is not less than 4 %.

All other circuits shall be verified." (IEC61439-1, 2009, p. 73)

The following example based on the network in Figure 26 shows how to determine the short-time withstand current I_{cw} .

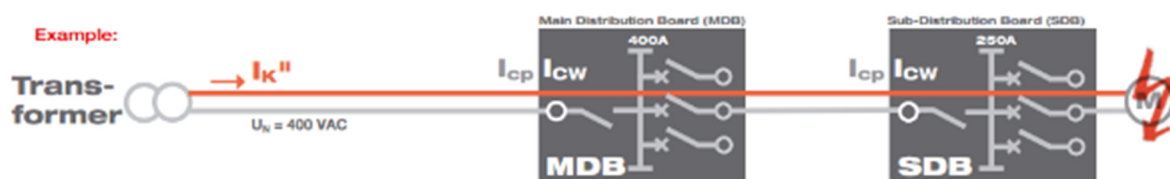

FIGURE 26. Path of the short-circuit current from the transformer to the short-circuit. (Hensel, 2015)

Step 1: Determining the transformer power and determining the value I_k''

The I_k'' can be determined by reading TABLE 3 or by using Equation 24. Hence the initial short-circuit current of the transformer is 9,025 kA.

TABLE 3. Transformer values. (Hensel, 2015)

Rated power of the transformer S_r in kVA	Rated current at rated voltage $U_n=400$ V a.c. I_N in A	Initial short-circuit current at $u_k = 4\%$ I_k'' in kA	Initial short-circuit current at $u_k = 6\%$ I_k'' in kA
100	144	3.610	2.406
160	230	5.776	3.850
250	360	9.025	6.015
315	455	11.375	7.583
400	578	14.450	9.630

$$I_k'' = \frac{S_N \cdot 100}{\sqrt{3} \cdot U_N \cdot u_k} \quad (24)$$

Step 2: Determining the rated short-time withstand current I_{cw} of the main distribution board (MDB)

The device with the lowest rated short-time withstand current I_{cw} installed in the main distribution board is the 400 A busbar with 15 kA (Table 4).

TABLE 4. MDB installed devices. (Hensel, 2015)

MDB installed devices	I_{cw} or I_{cu}
Circuit breaker 400A	$I_{cu} = 50\text{kA}^*$
Busbars 400A	$I_{cw} = 15\text{kA} / 1\text{s}^*$
MCCB 250A	$I_{cs} = I_{cu} = 8 \text{ kA} / 690 \text{ V a.c.}$ $I_{cs} = I_{cu} = 36 \text{ kA} / 415 \text{ V a.c.}^*$

The rated short-time withstand current I_{cw} of the MDB must be equal to or greater than the initial short-circuit current I_k'' of the transformer:

In this case the $I_{cw}(\text{MDB}) = 15 \text{ kA} \geq I_k''(\text{transformer}) = 9,025 \text{ kA}$.

In this analysis, the cable attenuation between the transformer and MDB is not considered. The cable attenuation can mean a reduction of the initial short-circuit current I_k'' . The prospective short-circuit current I_{cp} at the installation site of the MDB is smaller because of the cable attenuation than I_k'' of the transformer. (Hensel, 2015)

Step 3: Determining the rated short-time withstand current I_{cw} of the sub-distribution board (SDB)

The device with the lowest rated short-time withstand current I_{cw} installed in the main distribution board is the 250 A busbar with 15 kA (Table 5).

TABLE 5. SDB installed devices. (Hensel, 2015)

SDB installed devices	I_{cw}
Circuit breaker 250A	$I_{cu} = 50\text{kA} *$
Busbar 250A	$I_{cw} = 15\text{kA} / 1\text{s} *$
MCCB 160A	$I_{cs} = I_{cu} = 8\text{ kA} / 690\text{ V a.c.}$ $I_{cs} = I_{cu} = 36\text{ kA} / 415\text{ V a.c.} *$

I_{cp} is the prospective short-circuit current at the installation site of the assembly at the incoming terminals. It (I_{cp}) is calculated from transformer and cable data (length, cross section). Here, the cable attenuation due to distance and associated cable length between the transformer and sub-distribution board (SDB) is considered. The cable attenuation reduces the I_k'' of the transformer.

$$I_{cw}(\text{UV}) \geq I_{cw}(\text{HV}) > I_{cp} \geq I_k''(\text{transformer})$$

If a calculation is not possible, $I_{cp} = I_k''$ can be assumed.

The rated short-time withstand current (I_{cw}) must satisfy the following requirements:

$$I_{cw}(\text{UV}) \geq I_{cp}(\text{UV})$$

The rated short-time withstand current (I_{cw}) of the sub-distribution board is determined the same way as for the main distribution board. The respectively lowest value of the devices also determines the maximum rated short-circuit withstand current I_{cw} of the sub-distribution board. The panel builder must specify this value in the documentation of the assembly! (Hensel, 2015)

Assuming the bus bar short-circuit withstand current I_{cw} in the SDB installation is less than 9,025 kA the SDB installation would not stand a fault current and therefore not qualify for SCCR of 9,025 kA.

Comparing these example with the simulation done by ABB eDesign DOC (Figure 28) reveals that the example stands, except that the short-circuit current rating of the busbar in SDB is calculated with 9,87 kA. Still it is higher than the short-circuit current rating of the transformer. Figure 27 shows the short-circuit current of the busbar in SDB.

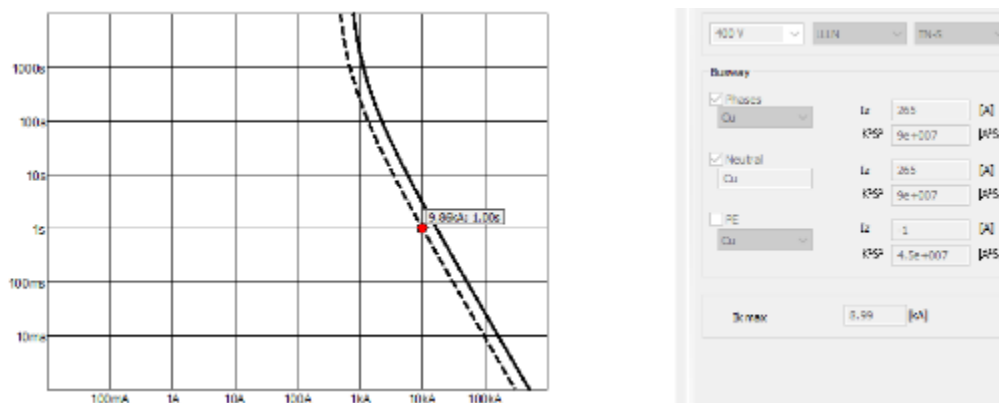

FIGURE 27. Short-circuit current of busbar.

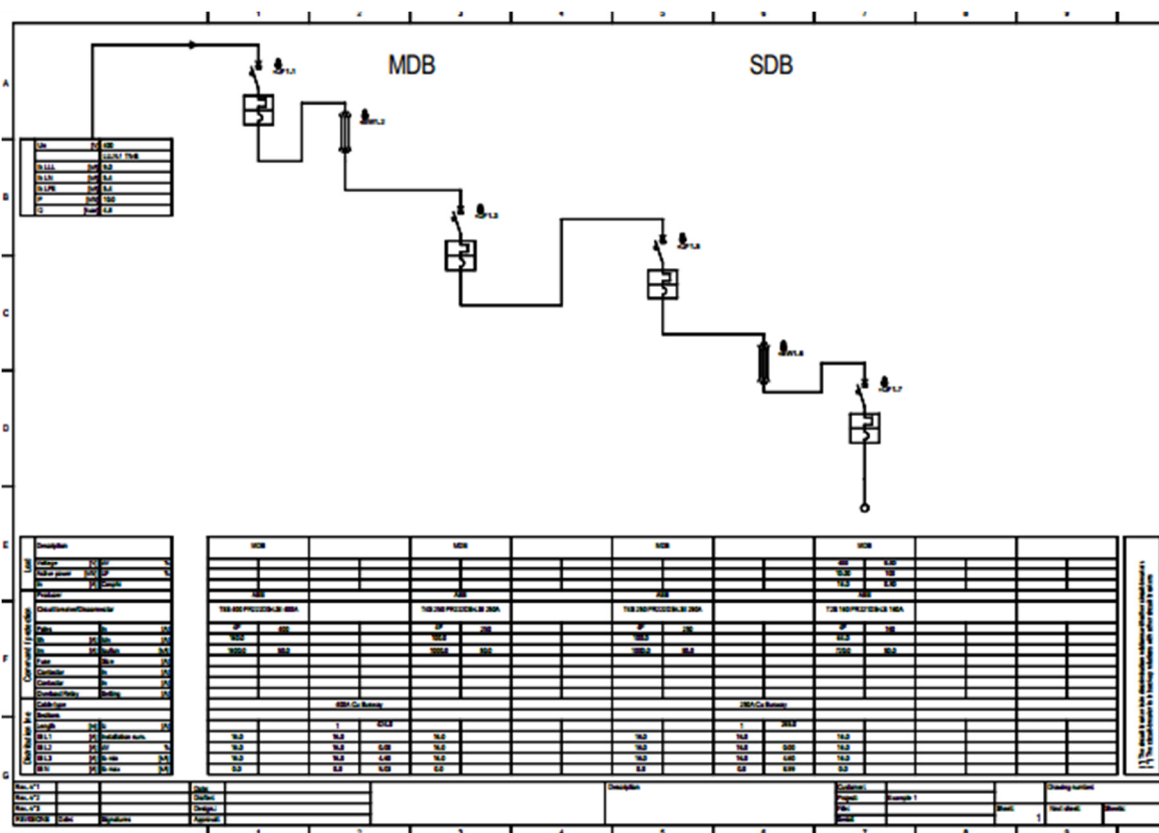

FIGURE 28. Example simulation by ABB eDesign DOC.

In other terms, the SCCR on the line side of feeder circuit breaker or fuse shall be the interrupting rating of the breaker if the following two conditions are fulfilled:

1. The components on the load side of the circuit breaker or fuse have a SCCR equal to or higher than the peak let-through current of the feeder circuit breaker or fuse
2. The branch protection devices have an interrupting rating equal or higher than the interrupting rating of the circuit breaker or fuse in the feeder circuit.

If condition 1. is not fulfilled, the lowest SCCR any component on the load side of the circuit breaker shall be the SCCR for the entire circuit on the line side of the feeder circuit breaker (see Figure 29).

If condition 2. is not fulfilled, the interrupting rating of the branch circuit protective device shall be the SCCR of the entire circuit on the line side of the feeder circuit breaker (see Figure 30).

The peak let-through values of the Circuit Breaker need to be provided by the Circuit Breaker manufacturer. (Siemens, 2014, p. 8)

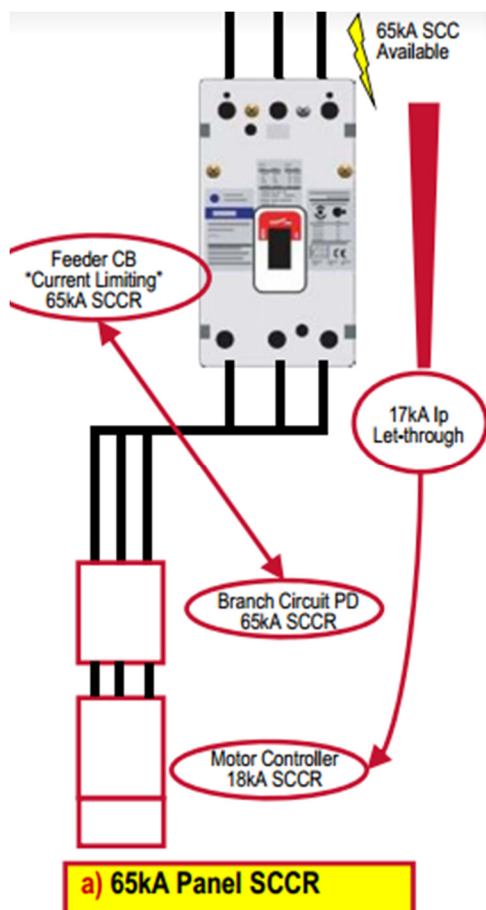

FIGURE 29. SCCR set by Main switch.
(Rockwell Automation, 2012, p. 16)

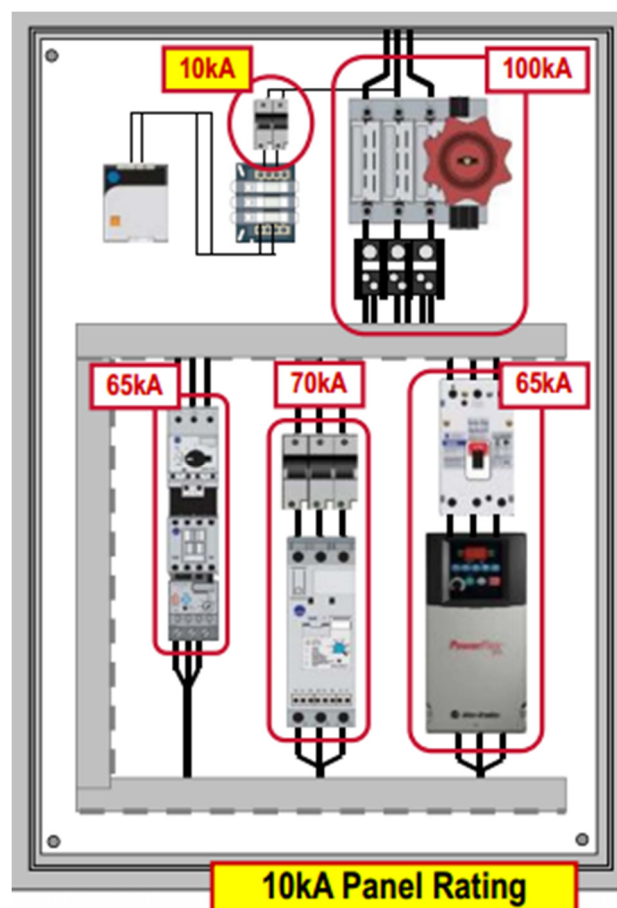

FIGURE 30. SCCR set by circuit breaker.
(Rockwell Automation, 2012, p. 17)

If the assembly user or subscriber does not provide the prospective short-circuit currents at the place of installation the manufacturer uses its design principle for the assembly and provides technical documentation which announces the short-circuit endurance. However, the assembly should at least withstand short-circuit currents at input terminals according to Table 6.

TABLE 6. Short-circuit withstand recommended minimum values for voltage of 400V. (SFS Käsikirja 154, 2005, p. 57)

assembly rated current I_n A	rated short-time withstand current (prospective r.m.s. value of the short-circuit current) I_{cw} kA	rated peak withstand current (peak value of the prospective short-circuit current) I_{pk} kA
≤ 125	< 5	< 7,5
$> 125 \leq$	5	7,5
$> 250 \leq$	6,3	10,7
$> 400 \leq$	12,5	25
$> 630 \leq$	16	32
$> 800 \leq$	20	40
$> 1000 \leq$	25	52,5
$> 1600 \leq$	31,5	66,2
$> 2000 \leq$	40	84
$> 2500 \leq$	50	105
$> 3150 \leq$	according to manufacturer and user or subscriber agreement	

8.3.1 Relationship between peak current and short-time withstand current

The short-circuit withstand current of a switchgear, stated as r.m.s. value I_{cw} indicates the thermal stress. The peak value I_{pk} indicates the dynamic stress on the switchgear.

“For determining the electrodynamic stresses, the value of peak current shall be obtained by multiplying the r.m.s. value of the short-circuit current by the factor n .” The values for the factor n and the corresponding power factor are given in Table 7 below. (IEC61439-1, 2009, p. 52)

TABLE 7. Values for the factor n . (IEC61439-1, 2009, p. 85)

r.m.s. value of short-circuit current kA	$\cos \varphi$	n
$I \leq 5$	0,7	1,5
$5 < I \leq 10$	0,5	1,7
$10 < I \leq 20$	0,3	2
$20 < I \leq 50$	0,25	2,1
$50 < I$	0,2	2,2

8.3.2 Thermal effects of short-circuit on busbar

Short-circuit currents cause the busbar temperature rise. The busbars final temperature must be lower than 160 °C so as not to damage the busbar support. The thermal constraints must be such that: (EEP, 2015, p. 122)

$$I_{sc}^2 \cdot t \leq K_E^2 \cdot S^2 \quad (25)$$

where

I_{sc} = r.m.s. short-circuit current in A

t = short circuit duration (generally equal to protection device operating time).

S = busbar section in mm²

K_E = coefficient given in Table 8 in relation to busbar temperature in normal operating conditions (before short circuit).

TABLE 8. Relation of busbar temperature in normal operating conditions. (EEP, 2015, p. 122)

Tf	40	50	60	70	80	90	100	110	120	130
K_E	89.2	84.7	80.1	75.4	70	65.5	60.2	54.8	48.5	41.7

8.4 Short-circuit current rating with current-limiting circuit breaker

The potential short-circuit withstand current after the prospective short-circuit current passes through a current-limiting circuit breaker can be attained from current-limitation curves provided by the manufacturer.

Example:

The prospective short-circuit current r.m.s. value is set to $I_p = 35$ kA

The limitation curve in Figure 29 of a ABB Tmax T5 circuit breaker indicates a dynamic withstand current of $I_{pk} = 30$ kA. The same limitation curve shows that the thermal current or rated short-time withstand current $I_{cw} = 15$ kA.

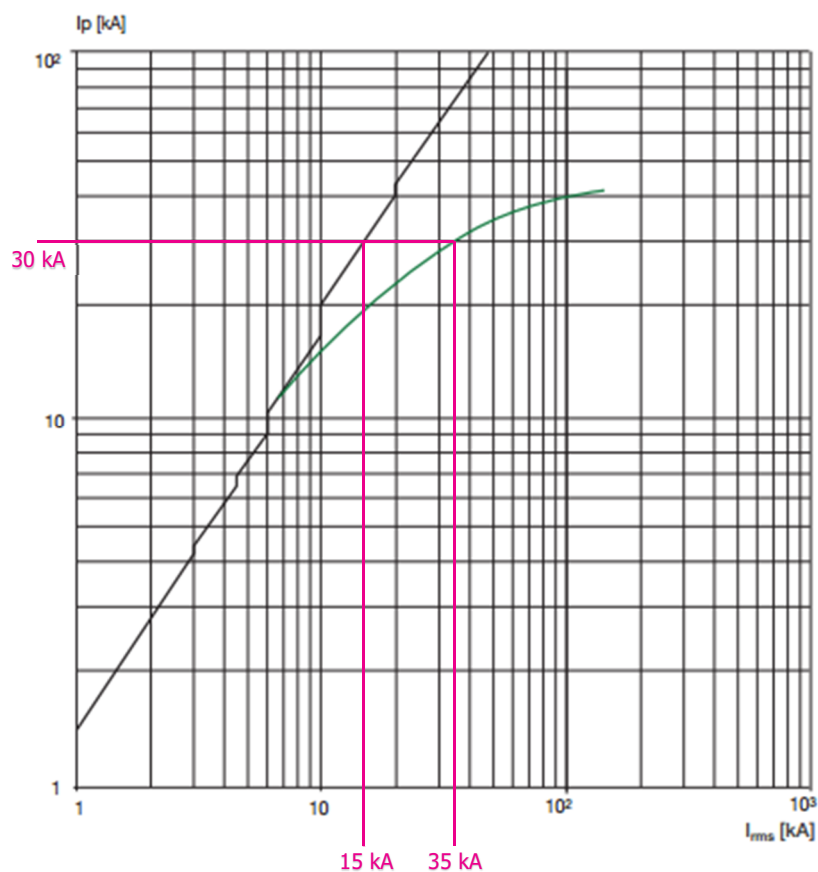

FIGURE 29. Limitation curve. (ABB, 2015, p. 164)

The rated short-circuit current is 15 kA but in practice the circuit breaker works much earlier and the switchgear does not actually undergo such large thermal stress. From the let-through energy curves in Figure 30 can be obtained that the energy passing through the circuit breaker during 1 second of fault current is $3 \cdot 10^6 \text{ A}^2\text{s}$. From this value can the actual passing short-circuit current be calculated. In Figure 12 is shown the relation of the let-through energy and the short-circuit current over time.

$$I_{1s}^2 \cdot t = \int_0^t I^2 dt$$

$$I_{1s}^2 \cdot 1 \text{ s} = 3 \cdot 10^6 \text{ A}^2\text{s} \rightarrow I_{1s}^2 = 3 \cdot 10^6 \text{ A}^2$$

$$I_{1s} = \sqrt{3 \cdot 10^6 \text{ A}^2} = 1,73 \text{ kA} \quad (26)$$

The circuit breaker limits the impact of the following installation to a short-circuit current during the time of 1 second to a value of 1,73 kA. As a result, at the switchgear nameplate can be following indicated $I_{cw} = 15 \text{ kA}$ and $I_{pk} = 30 \text{ kA}$.

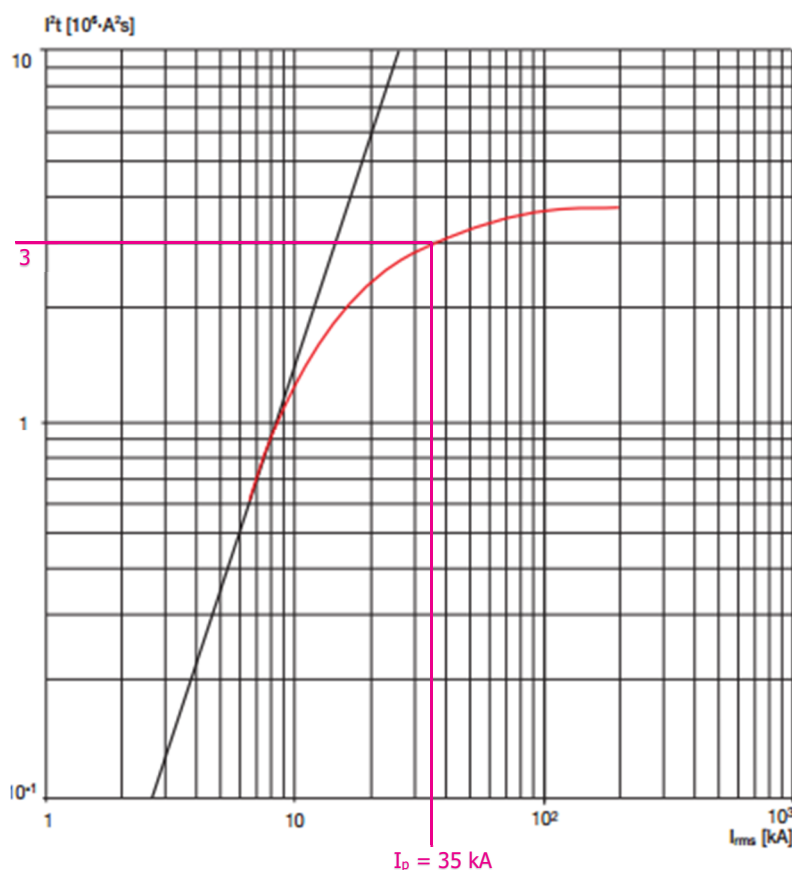

FIGURE 30. Let-through energy curve. (ABB, 2015, p. 154)

8.5 Short-circuit current rating with current-limiting fuse

The following example shows the decrease of short-circuit current achieved by current-limiting fuse. For current limitation a ABB OFAA 400 A fuse is used, which is feeding a sub distribution board as presented in Figure 34.

Example:

The rated short-time withstand current of main distribution board is set to $I_{cw} = 35$ kA. The rated peak withstand current can be calculated by obtaining the value n from Table 7.

$$I_{pk} = n \cdot I_{cw} = 2,1 \cdot 35 \text{ kA} = 73,5 \text{ kA} \quad (27)$$

If a sub distribution board is protected by the ABB OFAA 400 A fuse resided in the main distribution board than it can be obtained from Figure 31 that the fuse limits the instantaneous peak current to a value of about 32 kA, which is the rated peak withstand current (I_{pk}) of the sub distribution board. The peak current without current limiting fuse can be calculated according to Equation 7 as well can the approximate attained from the graph in Figure 31.

$$I_s = 1,44 \cdot \sqrt{2} \cdot 35 \text{ kA} = 71,27 \text{ kA} \quad (28)$$

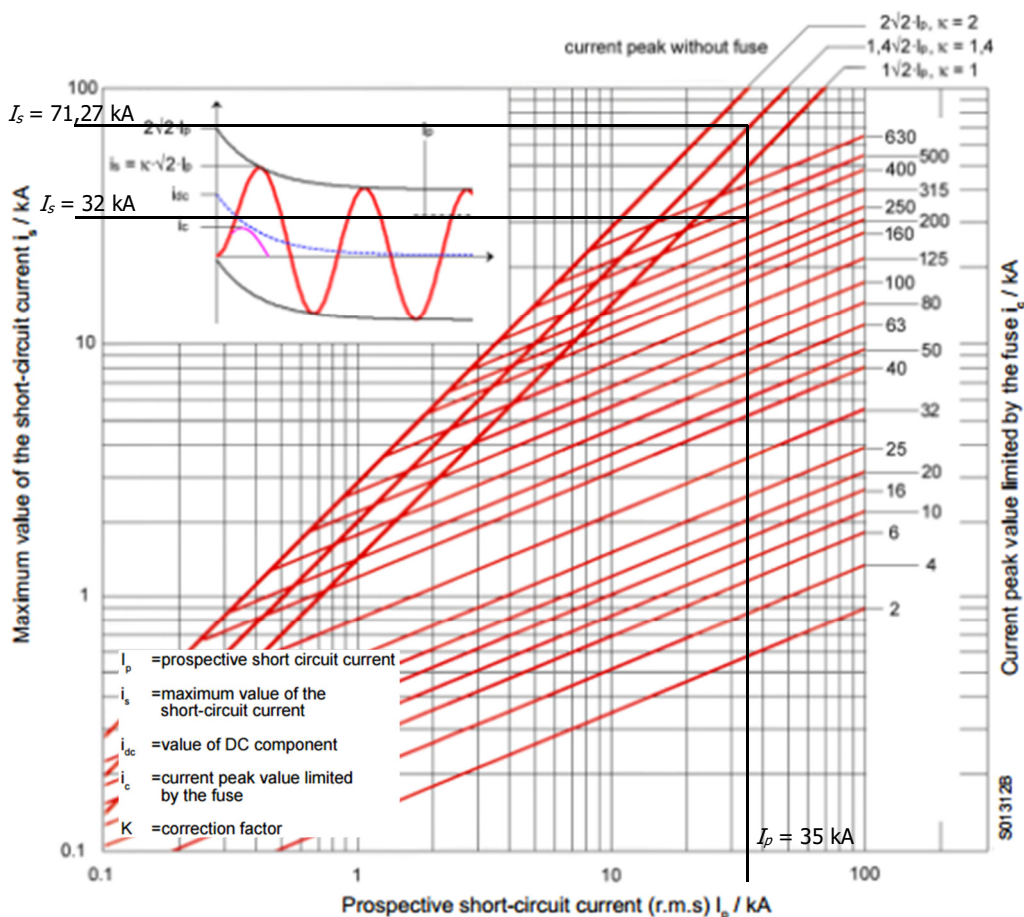

FIGURE 31. OFAA -fuses, current limitation. (ABB, 2010, p. 13)

For fuses working within the rated breaking capacity and a breaking time less than 0,01 s are joule integral graphs available, which indicates the passing energy through a fuse. Figure 35 shows that the joule integral I^2t of the 400 A OFAA is about $10^6 \text{ A}^2\text{s}$ for the time of 0,01 s. Equation 29 state the value for 1 s.

$$I_{1s}^2 \cdot t_{1s} = 10^6 \text{ A}^2\text{s} \rightarrow I_{1s}^2 = 10^6 \text{ A}^2 \rightarrow I_{1s} = \sqrt{10^6 \text{ A}^2} = 1 \text{ kA} \quad (29)$$

Figure 32 shows that the OFAA 400 A NH-fuse handles a 35 kA short-circuit current under 0,01 s time. Converting the obtained instantaneous peak short-circuit current of 35 kA into the value of 1 s according to Equation 5 leads to short-circuit current of 3,5 kA

$$I_{1s}^2 \cdot t_{1s} = I_s^2 \cdot t_{0,01s} \rightarrow I_{1s}^2 \cdot 1 \text{ s} = I_s^2 \cdot 0,01 \text{ s}$$

$$I_{1s} = I_s \cdot \sqrt{0,01} = 35 \text{ kA} \cdot \sqrt{0,01} = 3,5 \text{ kA} \quad (30)$$

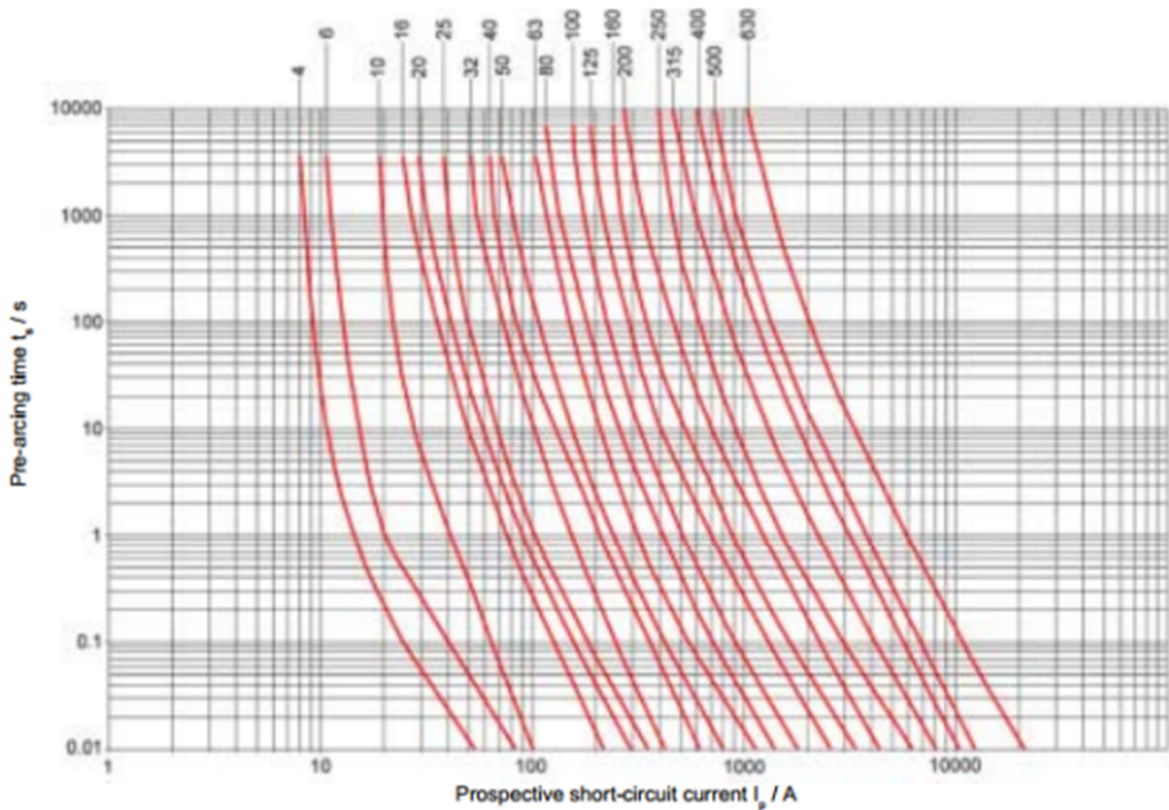

FIGURE 32. OFAA -fuses, time-current characteristics. (ABB, 2010, p. 12)

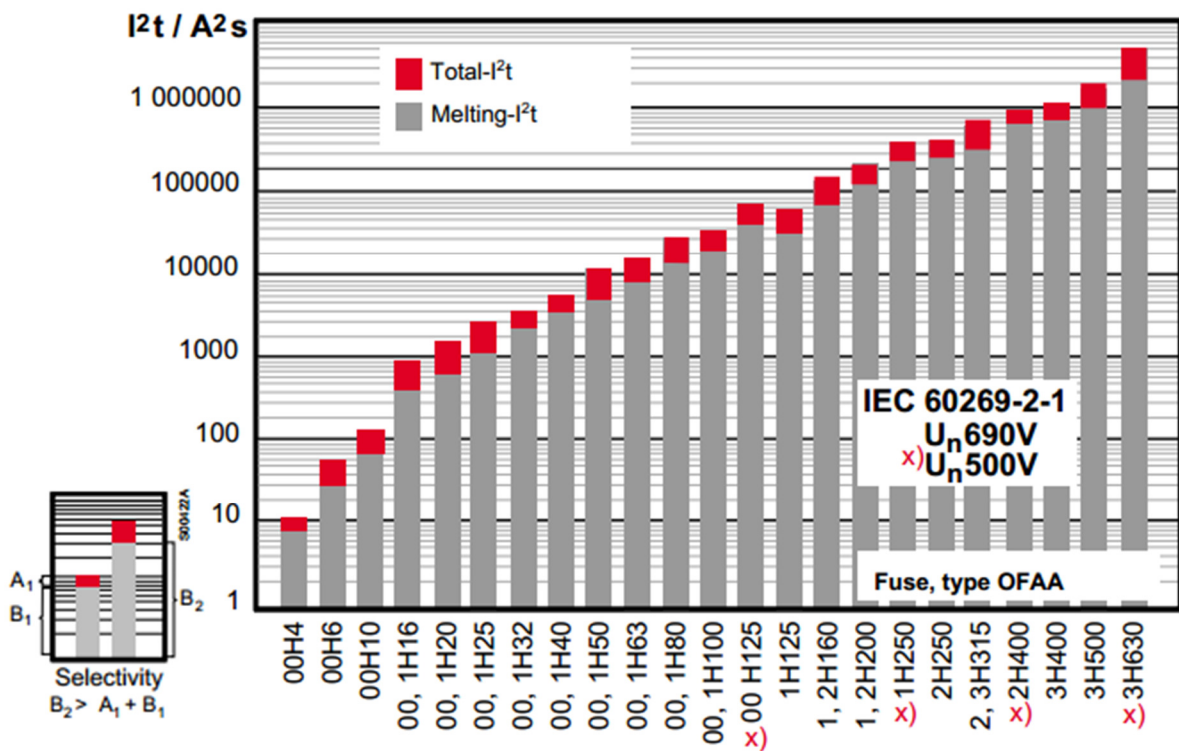

FIGURE 33. OFAA-fuses, I^2t -values. (ABB, 2010, p. 14)

Based on the thermal withstand of the fuse, the I^2t value for 1 s is 1 kA, which is considered to be the absolute the minimum value. From the fuse breaking time can be obtained a value of 3,5 kA, which is the maximum value.

The switchgear rated short-circuit current $I_{cf} = 35$ kA

On the nameplate need to be indicated: $I_{cf} = 35$ kA (fuse 400 A) and $I_{cw} \leq 10$ kA, $I_{pk} = 32$ kA.

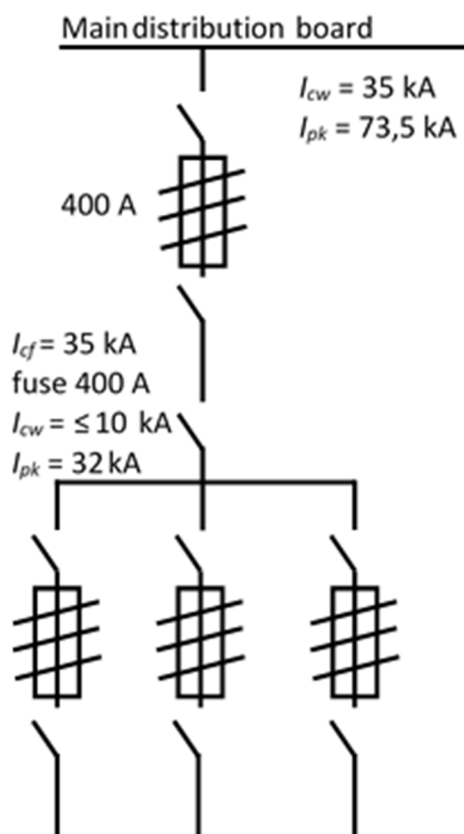

FIGURE 34. Example circuit with current-limiting fuse. (SFS Käsikirja 154, 2005, p. 108)

9 SHORT-CIRCUIT CURRENT CALCULATION TOOLS

Short-circuit calculation is a quite complex procedure, especially when the electrical network is divided by many substation or the network is structured as a mesh network, which is often the case. Electrical network design software is a helpful tool to determine the short-circuit current in a particular point in the network. Some common design software tools are ABB eDesign DOC, Schneider Electric Ecodial and DIgSILENT PowerFactory.

E Avenue Oy has been using mainly the ABB eDesign DOC program therefore this paper is concentrating on ABB eDesign DOC. ABB has a strong position in Finland and provides a good technical support. The use of ABB eDesign DOC is considerably easy and enables a fast definition of the network short-circuit values and suitable protective equipment. E Avenue Oy has a wide range of ABB components in its storage, thus the choice of ABB eDesign DOC is natural.

“ABB eDesign DOC is the ABB SACE program for drawing and calculating single-line diagrams of low and medium voltage electrical plants, for selecting the switching and protection devices and for verifying coordination of the protections.” (ABB, 2015, p. 6)

The main functionalities of the program are:

- Drawing single-line electric diagrams.
- Drawing the key diagram of the auxiliary circuits.
- Calculating line current and voltage drops.
- Calculating short-circuit currents.
- Dimensioning low and medium voltage cables.
- Dimensioning switching and protection devices.
- Calculating the temperature rise in ABB modular switchboards.
- Setting and coordinating protection devices.
- Verifying cable protection.
- Printing single-line diagrams and project documentation (ABB, 2015, p. 6)

The program can calculate electric networks with the following characteristics:

- Medium voltage: $V_n \leq 36\text{kV } 50/60\text{Hz}$
State of the neutral: Insulated / Compensated
- Low voltage: $V_n \leq 1\text{kV } 50/60\text{Hz}$
Three-phase power supplies with and without neutral, two-phase and single-phase Distribution system: TT – TN-S – TN-C – IT (ABB, 2015, p. 6)

10 EXAMPLE PROJECT ANALYSIS

The project, which is to be analysed, is of interest because there are actually different demands of the short-circuit withstand current capability by the customer as actually necessary. The network is only part of a larger project. The actual interest is concentrated to the one particular switchgear and the calculations are done until this point. Appendix 1 shows the partial network, framed in red, which is to be analysed. The same network is depicted in a simplified form in Figure 35. The switchgears of interest are named RKA-L6.1 and RKB-L6.1 (marked blue). The Figure 35 shows that the network is made up from two network parts. Since the two parts are the same, the calculations are done only for the left part until switchgear RKA-L6.1. The busbar between the two network parts is only used to feed the other network in case there is no possibility to feed the particular part by either the transformer or the generator. As seen from the main diagram in Appendix 3 the rated short-time withstand current $I_{cw} = 50 \text{ kA}$ and the rated peak withstand current $I_{pk} = 100 \text{ kA}$ set by the customer are exceptionally high for a switchgear with a rated current of 125 A. The actual values are seen in Appendix 2 with $I_{cw} = 1,7 \text{ kA}$ and $I_{pk} = 17 \text{ kA}$. It is to be noticed that additionally the rated conditional short-circuit current of the assembly (I_{cc}) is stated with 50 kA.

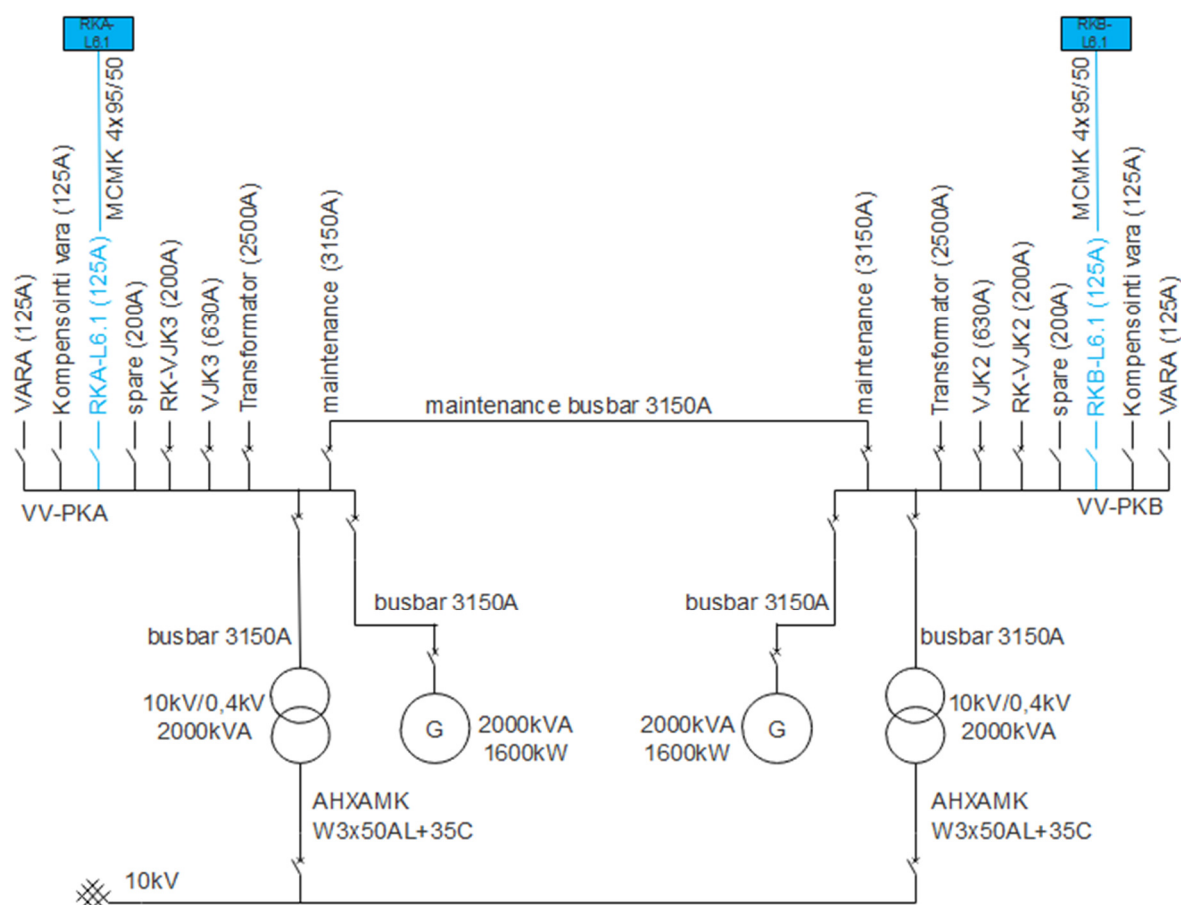

FIGURE 35. Analysed network.

10.1 Calculations for the short-circuit currents

Calculations for the short-circuit currents are done "by hand" using the *composition method* and then compared with the values calculated by ABB eDesign DOC.

To select the protecting circuit breaker for the main distribution board, the rated current at feeding point is needed. The transformers' rated current on the secondary side can be obtained from tables like the Table 2 as well can the short-circuit current. If such table is not available, the rated current can be calculated, with the given values for the 10 kV / 0,4 kV transformer are: $S_N = 2000$ kVA, $z_k = 6\%$, as follow:

$$I_N = \frac{S_N}{\sqrt{3} \cdot U_{2N}} = \frac{2000 \text{ kVA}}{\sqrt{3} \cdot 400 \text{ V}} = 2886,75 \text{ A} \quad (31)$$

Omitting the attenuation from the busbar trunking system, the value above is the rated current and as seen in Figure 35 the main circuit breaker is designed to handles a current of 3150 A.

The short-circuit current is calculated as follow:

$$I_k = \frac{I_N}{z_k} = \frac{2886,75 \text{ A}}{0,06} = 48,11 \text{ kA} \quad (32)$$

Alternatively, the short-circuit current can be calculated through the transformer short-circuit power.

$$S_{kT} = \frac{S_N}{z_k} = \frac{2000 \text{ kVA}}{0,06} = 33,33 \text{ MVA} \quad (33)$$

The short-circuit power is needed when combining different parts of the network like described in chapter 5.4. The short-circuit of the transformer than is slightly higher since the voltage factor according to Table 1 will be applied when using the composition method:

$$I_k'' = \frac{c \cdot S_k}{\sqrt{3} \cdot U_{2N}} = \frac{1,05 \cdot 33,33 \text{ MVA}}{\sqrt{3} \cdot 400 \text{ V}} = 50,51 \text{ kA} \quad (34)$$

The peak short-circuit is then calculated according to Equation 7

$$I_p = 1,44 \cdot \sqrt{2} \cdot 50,51 \text{ kA} = 102,87 \text{ kA} \quad (35)$$

Next step is to calculate the attenuation of short-circuit current caused by the busbar trunking system. The needed data for the busbar is given by the table shown in Appendix 4. Values obtained

from the table are 0,0000202 Ω /m for the resistance and 0,0000277 Ω /m for the reactance. Assuming that the busbar is 8 m long the impedance is then calculated as follow.

$$\begin{aligned} Z_{bus} &= l \cdot R_{bus} + l \cdot j \cdot X_{bus} \\ Z_{bus} &= 8 \text{ m} \cdot 0,0000202 \Omega / \text{m} + 8 \text{ m} \cdot j \cdot 0,0000277 \Omega / \text{m} \\ Z_{bus} &= 0,0002743 \angle 53,9^\circ \Omega \end{aligned} \quad (36)$$

The busbar short-circuit power is then

$$S_{kbus} = \frac{U_{2N}^2}{Z_{bus}} = \frac{(400 \text{ V})^2}{0,0002743 \Omega} = 583 \text{ MVA} \quad (37)$$

The sum of the two short-circuit power is according to Equation 16

$$\frac{1}{S_k} = \frac{1}{S_{kT}} + \frac{1}{S_{kbus}} = \frac{1}{33,33 \text{ MVA}} + \frac{1}{583 \text{ MVA}} = 31,53 \text{ MVA} \quad (38)$$

The following calculation leads to the available the r.m.s. value of the short-circuit current at feeding point of switchgear VV-PKA.

$$I_k'' = \frac{c \cdot S_k}{\sqrt{3} \cdot U_{2N}} = \frac{1,05 \cdot 31,53 \text{ MVA}}{\sqrt{3} \cdot 400 \text{ V}} = 47,79 \text{ kA} \quad (39)$$

The peak short-circuit is then

$$I_p = 1,44 \cdot \sqrt{2} \cdot 47,79 \text{ kA} = 97,31 \text{ kA} \quad (40)$$

The calculation can be continued for the switchgear RKA-L6.1. The feeding cable, MCMK 4X95/50, has a resistance of 0,193 Ω /km and inductance of 0,21 mH/km according to Appendix 5. The length is to be assumed 5 m. For the calculation of the impedance the values for resistance and reactance are needed. The reactance is calculated from the inductance in relation to the network frequency, which is 50 Hz.

$$X = 2\pi fL = 2 \cdot \pi \cdot 50 \text{ Hz} \cdot 0,00021 \text{ H/km} = 0,066 \Omega / \text{km} \quad (41)$$

Now the impedance of the cable can be calculated

$$\begin{aligned}
 Z_{cable} &= l \cdot R_{cable} + l \cdot j \cdot X_{cable} \\
 Z_{cable} &= 0,005 \text{ km} \cdot 0,193 \Omega / \text{km} + 0,005 \text{ km} \cdot j \cdot 0,066 \Omega / \text{km} \\
 Z_{cable} &= 0,00102 \angle 18,88^\circ \Omega
 \end{aligned} \tag{42}$$

The MCMK 4x95/50 cable short-circuit power is then

$$S_{kbus} = \frac{U_{2N}^2}{Z_{cable}} = \frac{(400 \text{ V})^2}{0,00102 \Omega} = 156,86 \text{ MVA} \tag{43}$$

The sum of the short-circuit power is

$$\frac{1}{S_k} = \frac{1}{S_{kT}} + \frac{1}{S_{kbus}} + \frac{1}{S_{kcable}} = \frac{1}{33,33 \text{ MVA}} + \frac{1}{583 \text{ MVA}} + \frac{1}{156,86 \text{ MVA}} = 26,25 \text{ MVA} \tag{44}$$

The available the r.m.s. value of the short-circuit current at the feeding point of switchgear RKA-L6.1 is then

$$I_k'' = \frac{c \cdot S_k}{\sqrt{3} U_n} = \frac{1,05 \cdot 26,25 \text{ MVA}}{\sqrt{3} \cdot 400 \text{ V}} = 39,78 \text{ kA} \tag{45}$$

The peak short-circuit is then calculated according to Equation 7

$$I_p = 1,44 \cdot \sqrt{2} \cdot 39,78 \text{ kA} = 81,02 \text{ kA} \tag{46}$$

Calculations done by ABB eDesign DOC shown in Appendix 6, with 26,68 kA, are considerable lower than the result above. The reason is that the short-circuit current of the transformer is stated lower and different values for the busbar trunking system and cable are applied.

10.2 Determination of SCCR

Regardless of whether the calculations are done conventionally or with ABB eDesign DOC the resulting short-circuit current at the feeding point of the sub distribution board is still much higher as the actually needed withstand current. Therefore, the approach to get the right withstand current rating or SCCR has to be another.

Since the rated current for the switchgear is known the protection device, whether it is a circuit breaker or a fuse can be selected accordingly. In this example the protection on the switchboard is achieved by a ABB OFAA 125 A fuse (see Appendix 2). As already explained in chapter 8.5, knowing the short-circuit current at feeding side of the fuse it is possible with the help fuse current-limitation chart to find the short-circuit current the fuse is actually letting through. Using the demanded short-circuit current value of 50 kA it can be obtained from Figure 36 that the 125 A OFAA fuse limits the maximum instantaneous peak current to value of 17 kA. It can be also seen that the available peak short-circuit current, meaning the peak current without the fuse is 100 kA.

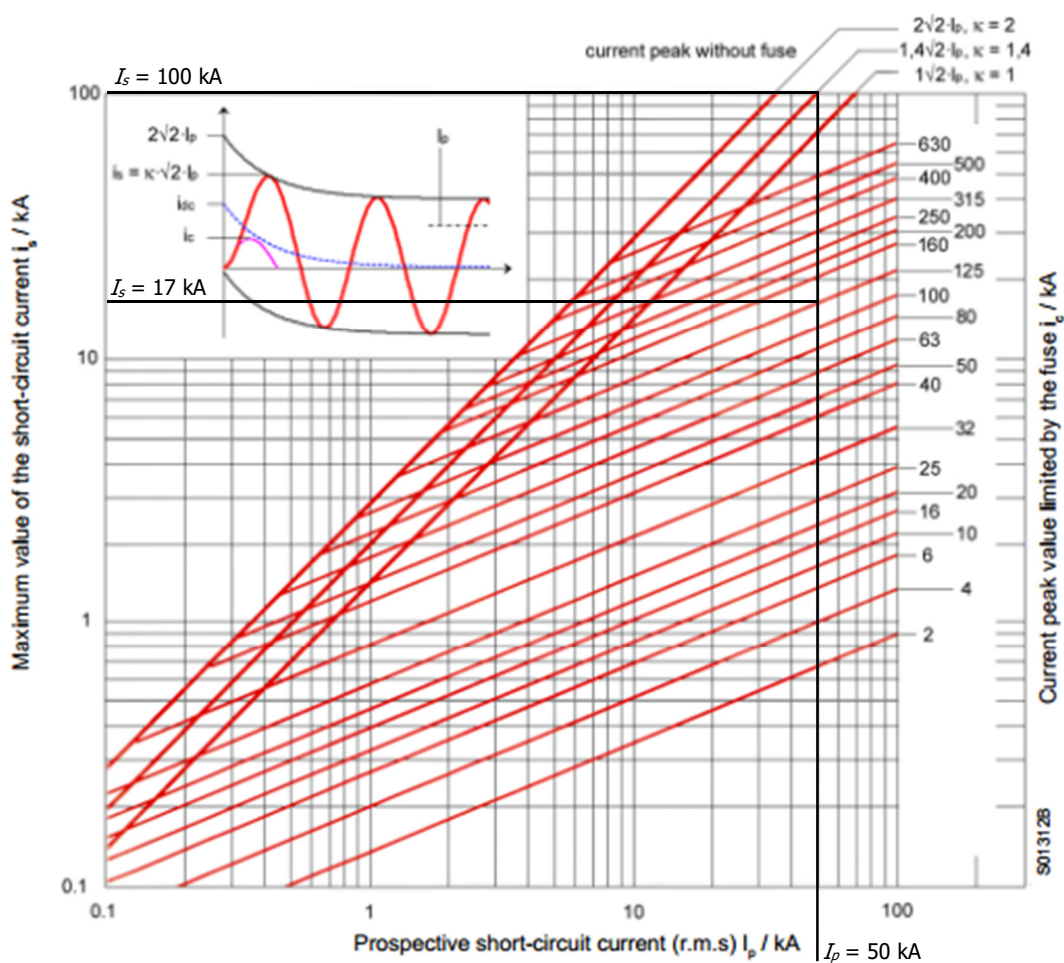

FIGURE 36. Fuse current limitation. (ABB, 2010, p. 13)

Figure 32 shows that the ABB OFAA 125 fuse handles a 50 kA short-circuit current under 0,01 s time. Converting the obtained instantaneous peak short-circuit current of 17 kA into the value of 1 s according to Equation 5 leads to short-circuit current of 1,7 kA

$$I_{1s} = I_p \cdot \sqrt{0,01} = 17 \text{ kA} \cdot \sqrt{0,01} = 1,7 \text{ kA} \quad (47)$$

Figure 35 shows that the joule integral I^2t of the 125 A fuse is about $7 \times 10^4 \text{ A}^2\text{s}$ for the time of 0,01 s. Equation 48 state the value for 1 s.

$$I_{1s}^2 \cdot t = \int_0^t I^2 dt \quad \rightarrow \quad I_{1s} = \sqrt{7 \cdot 10^4 \text{ A}^2} = 264,58 \text{ A} \quad (48)$$

As a result, the switchgear can be designed so that it has a rated short-time withstand current of $I_{cw} \leq 10 \text{ kA}$ and a rated peak withstand current of $I_{pk} = 17 \text{ kA}$.

Based on the thermal withstand of the fuse, the I^2t value for 1 s is 265 A, which is considered to be the absolute the minimum value because if the short-circuit current is lower, the fuse clearing time is longer than 1 /2 cycle of the prospective peak short-circuit current (see Figure 11) and the fuse would not limit the current. From the fuse breaking time can be obtained a value of 1,7 kA, which is the maximum value.

Since the protecting 125 A fuse resided in the main board limits the let-through current to a value of 1,7 kA for the duration of 1 s the sub board is well protected. On the nameplate (FIGURE 37) has to be indicated the rated conditional short-circuit current $I_{cc} = 50 \text{ kA}$, which is equal to the prospective r.m.s. value of short-circuit current $I_p = 50 \text{ kA}$. This complies with the standard IEC61439-1 as mentioned in chapter 3.2.6.

As a result the sub distribution board has a withstand current rating of $I_{cw} \leq 10 \text{ kA}$ since all the components inside can withstand a short-circuit current of 10 kA. On the nameplate need to be indicated: $I_{cf} = 50 \text{ kA}$ (fuse 125 A) and $I_{cw} \leq 10 \text{ kA}$, $I_{pk} = 17 \text{ kA}$.

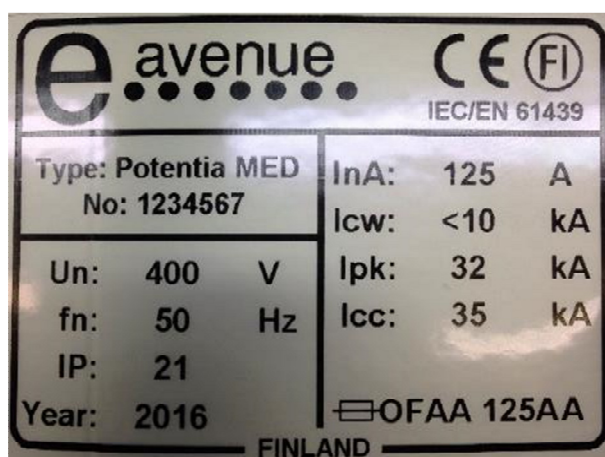

FIGURE 37. Nameplate. (E Avenue Oy, 2015)

11 CONCLUSION

The subject of this thesis was to investigate the short-circuit currents in an electrical network, its cause and emergence. The magnitude is determined by calculations and with the help of network calculations programs such as the introduced ABB eDesign DOC. The impact of short-circuit currents, which are often have a magnitude of several thousand amperes, on switchgears can cause hazard to humans and severe damages to the components inside the switchgear. The consequences can be of enormous economical distress because of expensive replacement for damaged parts and downtimes in production since industrial switchgears distribute electrical energy to the machineries. Therefore, it is important to know precisely the potential short-circuit current magnitude when designing switchgears in a safe and economical way. Different methods of current-limiting are described and the use of protective devices together with their coordinations through selectivity and back-up protection.

The thesis studied the short-circuit currents in theory with practical examples. As it turned out the determination of a short-circuit withstand current or SCCR is not that simple especially when the installation deals with high rated currents above 3000 A. Until that value tables such as TABLE 6 in chapter 8.3 are available to find the right short-circuit withstand current. Determine the right SCCR for sub distribution switchgears is often a problem, since the attenuating effect of the protecting devices in the main board is not taken into account by calculation software.

To find an optimised way to determine the SCCR of a switchgear, a combination of different methods is required. Network calculation software is a fast and simple way to find out the short-circuit current at the feeding point of a mainboard. Based on these figures the protective device is to be chosen. Then the actual potential short-circuit current, which passes through the protective device is taken into account for setting the short-circuit withstand current of the following sub distribution board. Manufactures provide detailed information about switching time and current-limiting, such as let-through curves introduced in chapter 8.4 and 8.5. Additional and more precise protection can be achieved by cascading protective devices or using the back-up protection.

The fact is that that simple software or spreadsheet tables are not available to determine the short-circuit withstand current of switchgears. Each switchgear has to be individually designed by taking the SCCR of selected components into account.

12 REFERENCES

- ABB. (2008, 6 23). *Low voltage switchgear*. Retrieved 3 3, 2016, from http://www.dii.unipd.it/~gobbo/didattica/corsi/Componenti_tecnologie_elettrici/ABB_swithgear_manual_E11/ABB_11_E_07_druck.pdf
- ABB. (2010, 4 10). *Low Voltage Products, FuseLine HRC Fuse Links, gG and aM -types*. Retrieved 3 3, 2016, from http://www.cablejoints.co.uk/upload/ABB_LV_Low_Voltage_Fuses_&_Fuse_Links.pdf
- ABB. (2015, 5 8). *Doc User Manual*. Retrieved 2 23, 2016, from https://library.e.abb.com/public/a7a540898e0685bdc1257e1a0048b3ef/DOC_UserManual_EN_SLD.pdf
- ABB. (2015, 10 10). *Low voltage selectivity with ABB circuit-breakers*. Retrieved 3 3, 2016, from <https://library.e.abb.com/public/65ddf36f7c3bd0fec1257ac500377a37/1SDC007100G0204.pdf>
- ABB. (2015, 5 11). *SACE Tmax Technical catalogue*. Retrieved 3 3, 2016, from <https://library.e.abb.com/public/66c18a8306bdf816c1257b50002f4f4c/1SDC210015D0207.pdf>
- Alam, & Saif, A. (2014). *Short circuit current calculation and prevention in High Voltage Power nets*. Karlskrona: School of Engineering Blekinge Institute of Technology. Retrieved from <http://www.diva-portal.org/smash/get/diva2:830521/FULLTEXT01.pdf>
- Bussmann. (2013, 10 19). *Introduction and Current-Limitation*. Retrieved 3 3, 2016, from Component Protection: http://www.cooperindustries.com/content/dam/public/bussmann/Electrical/Resources/solution-center/technical_library/BUS_Ele_Tech_Lib_Current_Limitation.pdf
- Bussmann. (2013, 10 19). *Short-Circuit Current Ratings*. Retrieved 3 3, 2016, from http://www.cooperindustries.com/content/dam/public/bussmann/Electrical/Resources/solution-center/short_circuit_current-ratings/BUS_Ele_2008_NEC_SCCR_Requirements.pdf
- E Avenue Oy. (2015). *High-quality manufacturer of power distribution centres*. (E Avenue Oy) Retrieved 11 12, 2015, from <http://www.eavenue.fi/eng/company.html>
- E Avenue Oy. (2015). Project documentation.
- Eaton. (2013, 10). *Power Xpert® Busbar Product guide*. Retrieved 4 15, 2016, from Power Xpert® Busbar: http://www.eaton.eu/ecm/idcplg?IdcService=GET_FILE&allowInterrupt=1&RevisionSelectionMethod=LatestReleased&noSaveAs=0&Rendition=Primary&dDocName=PCT_345920
- Eaton. (2015). *Selectivity, Back Up Protection and Coordination Guide*. Retrieved 3 4, 2016, from http://www.eaton.de/ecm/groups/public/@pub/@europe/@electrical/documents/content/pct_1198913_de.pdf
- EEP. (2015, 6 4). *Application-Guide-Industrial-Switching-and-Protection-Systems*. Retrieved 3 8, 2016, from <http://electrical-engineering-portal.com/res/Application-Guide-Industrial-Switching-and-Protection-Systems.pdf>

- Electrical Installation Wiki Schneider Electric. (2015, 7 17). *The advantages of current limitation*. (Schneider Electric) Retrieved 3 3, 2016, from Other characteristics of a circuit-breaker: http://www.electrical-installation.org/enwiki/Other_characteristics_of_a_circuit-breaker
- Else Engineering. (2016). *Short Circuit Faults*. (Else Engineering Company Pty Ltd) Retrieved 2 21, 2016, from <http://else-engineering.com.au/home/power/short-circuit-calculation/>
- Hensel. (2015, 6 10). *Design of an assembly and design verification*. Retrieved 3 5, 2016, from Determining the rated short-time withstand current (I_{cw}) of a circuit of an assembly: <http://www.hensel-electric.de/media-61439/docs/EN/leitfaden-schritt-2-kurzschlussfestigkeit-en.pdf>
- IEC60865-1. (1993). Short-circuit currents – Calculation of effects – Part 1: Definitions and calculation methods. (*Second edition*). International Electrotechnical Commission.
- IEC60909-0. (2001). Short-circuit currents in three-phase a.c. systems - Part 0: Calculation of currents. (*First edition*). International Electrotechnical Commission.
- IEC60909-1. (2002). Short-circuit currents in three-phase a.c. systems – Part 1: Factors for the calculation of short-circuit currents according to IEC 60909-0. (*Second edition*). International Electrotechnical Commission.
- IEC60909-2. (2008). Electrical Equipment – Data for Short Circuit Current Calculations in Accordance with IEC 909. International Electrotechnical Commission.
- IEC60909-3. (2009). Short-circuit currents in three-phase AC systems - Part 3: Currents during two separate simultaneous line-to-earth short circuits and partial short-circuit currents flowing through earth. International Electrotechnical Commission.
- IEC60909-4. (2000). Short-circuit currents in three-phase a.c. systems – Part 4: Examples for the calculation of short-circuit currents. (*First edition*). International Electrotechnical Commission.
- IEC61439-1. (2009). Low-voltage switchgear and controlgear assemblies – Part 1: General rules. (*Edition 1.0*). International Electrotechnical Commission.
- JADE Learning. (2016). *Definitions: Current-Limiting Overcurrent Protective Device*. Retrieved 3 3, 2016, from <http://www.jade1.com/jadecc/courses/UNIVERSAL/NEC05.php?imDif=2465.0>
- Littelfuse. (2009). *Using Current-limiting Fuses to Increase SCCR*. Retrieved 3 3, 2016, from http://www.ttiinc.com/object/wp_littelfuse_using_fuses_increase_sccr.html
- Nexans. (2016). *MCMK 95/50 Datasheet*. Retrieved 4 15, 2016, from http://www.nexans-fi.com/eservice/Finland-fi_FI/pdf-product_540150980/MCMK_1_kv_4X95_50.pdf
- Nilsson, M. (2010). *Short-circuit analysis of the onsite electric power*. Gothenburg: Chalmers University of Technology.

- Rockwell Automation. (2012, 11 27). *Global "Short-Circuit Current Ratings"*. Retrieved 4 20, 2016, from https://www.rockwellautomation.com/resources/downloads/rockwellautomation/pdf/events/automation-fair/2012/tech-sessions/t41_global-sccr-solutions.pdf
- Rockwell Automation. (2016, 4). *Low-Voltage Switchgear and Controlgear Technical Document*. Retrieved 1 21, 2016, from http://literature.rockwellautomation.com/idc/groups/literature/documents/rm/lvsam-rm001_en-p.pdf
- Schlabbach, J. (2005). *Short-circuit Currents*. London: The Institutio of Technology an Engineering. Retrieved from <http://www.shirazedc.co.ir/DorsaPax/userfiles/file/Ebook/Short%20Circuit%20Current%20-%20Schlabbach.pdf>
- Schneider Electric. (2009, 3 11). *Calculation of short-circuit*. Retrieved 2 17, 2016, from <http://www2.schneider-electric.com/documents/technical-publications/en/shared/electrical-engineering/electrical-know-how/low-voltage-minus-1kv/ect158.pdf>
- SFS. (2016). *SFS in brief*. (Finnish Standards Association) Retrieved 2 21, 2016, from http://www.sfs.fi/en/sfs_in_brief
- SFS Käsikirja 154. (2005). SFS Käsikirja 154 Jakokeskukset. Suomen Standardisoimisliitto.
- Siemens. (2014, 8 7). *Fuse Systems Technology Primer*. Retrieved 3 3, 2016, from https://www.lowvoltage.siemens.com/infocenter/doc/04_ds_FuseSystemsPrimer_EN_968.pdf
- Siemens. (2014, 10). *Guidelines on the Short Circuit Current Rating for Industrial Control Panels*. Retrieved 4 18, 2016, from http://www.automationworld.com/sites/default/files/custom/2015/sccr_wp.pdf
- Stojanovic, J. N. (2012, 6 1). *CALCULATION OF THERMAL EQUIVALENT SHORT TIME CURRENT*. Retrieved 2 23, 2016, from <http://facta.junis.ni.ac.rs/eae/facta9801/art7.pdf>

APPENDIX 1: ANALYZED NETWORK (E AVENUE OY, 2015)

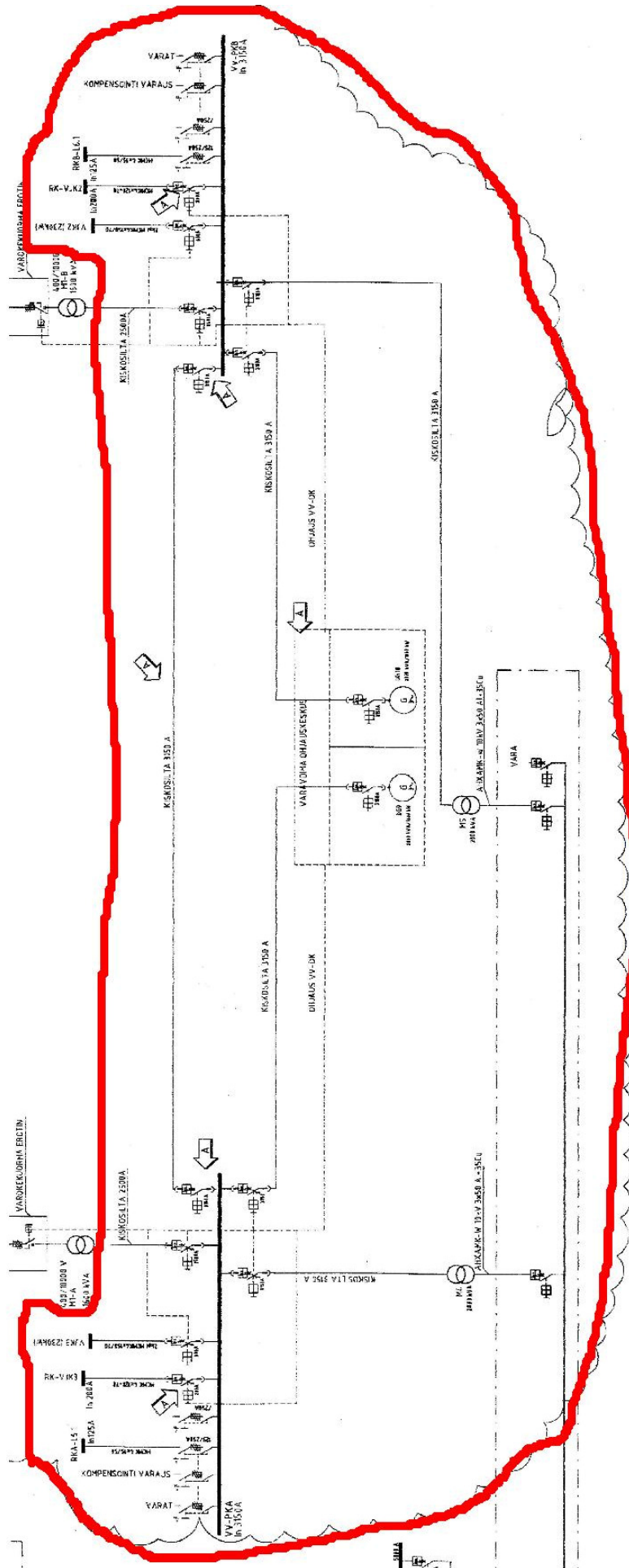

APPENDIX 2: SWITCHGEAR RKA-L6.1 DESIGN (E AVENUE OY, 2015)

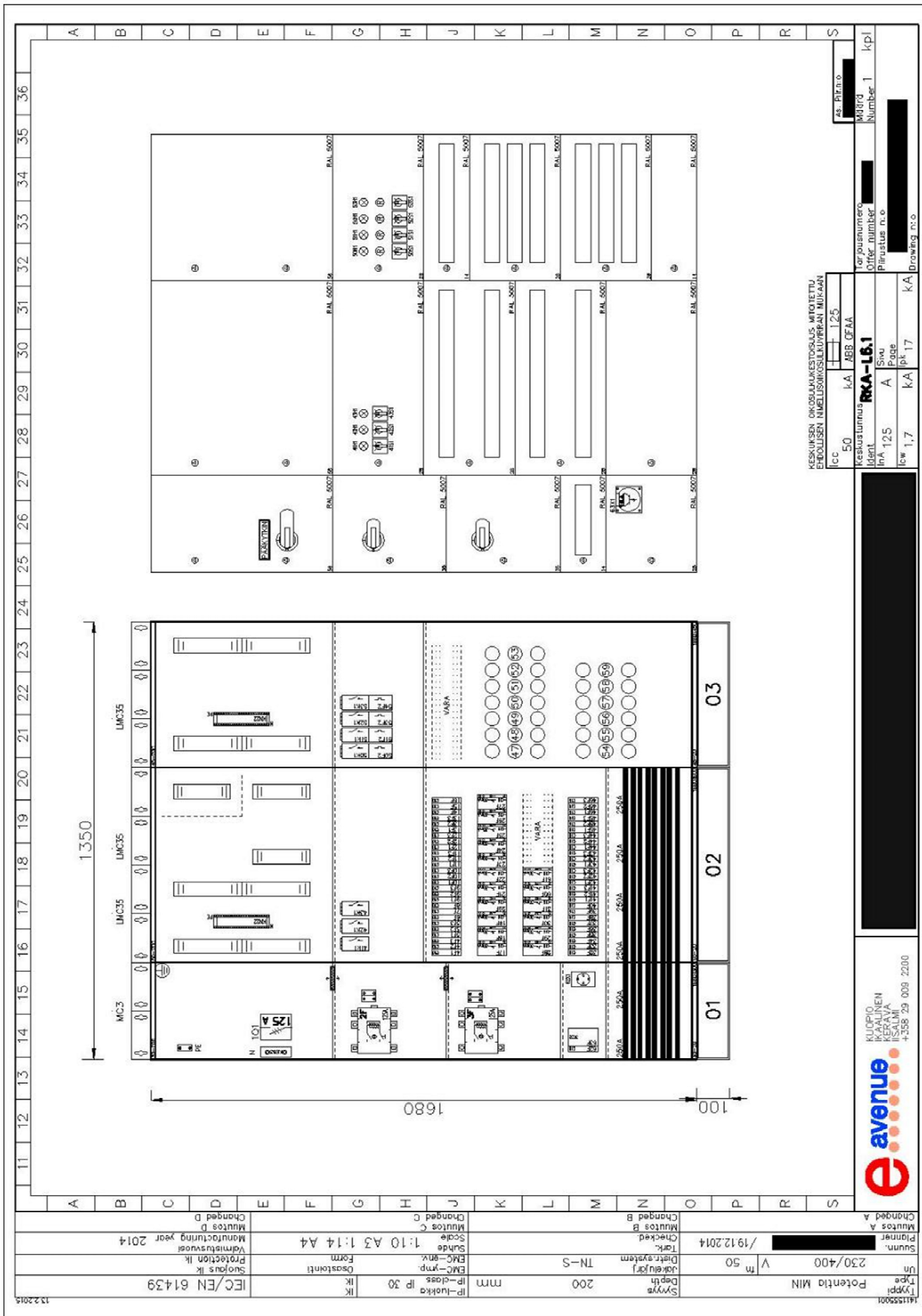

APPENDIX 3: SWITCHGEAR RKA-L6.1 CUSTOMER WITHSTAND DEMANDS (E AVENUE OY, 2015)

D	KTS. MS09	MPH	TEKSTI	LEHTI
C	KTS. MS05	AKS		1/5
B	KTS. MS02	AKS		MAITOS
A	KTS. MS01	AKS		
		MS01		

D	KALUSTUS- JA KAAPELOINTITIEDOT	LEHTI
1	Kalustustapa: - kaakelit - yksikkölohdot	1/5
2	Kalustuksen tyyppi: - kiinteä - ulosotettava - ulosvedettävä	
3	Merkitämpi: - merkkipöytä - hoitopöytä - led-lampot	
4	Laskutuslaitteiden toimittaja: - Hiaaja - keskusvalmistaja / urakoitsija	
5	Laskutuslaitteiden toimittaja: - Hiaaja	
6	Muiden laitteiden koko:	
7	Syöttö: - kaapeli - kiskosto	
8	Syöttö tulo: - aihaita - yhäältä - vasemmalta - oikealta	
9	Kaapeleiden lähtösuunta: - alas	
10	Pääpiirin kaapeleiden lähtösuunta: - ylös - kojeisiin - rivillä - rivillä, myös N ja PE - kojeisiin alkaen	
11	Ohjauksen lähtösuunta: - vasemmalta - oikealta	

C	HYVÄKSYTTÄMINEN JA MERKINNÄT	LEHTI
1	Kokoonpanopöytäruokaset hyväksyy: - suunnitelma - valvoja - sähkölaite	
2	Merkitämpi: - vain viranomaisvaatimukset - suunnitelman mukaan - erillisen ohjeen mukaan	
3	Keskukseen tunnuslausekset: - vain viranomaisvaatimukset - pääkaavion mukaan	
4	Käpien materiaali: - herrossuovi - farra	
5	Keskukseen kehitettävien tunnuslausekset: - valmistajan normaalit - vasaamalla oikealle - oikealla vasemmalle	
6	Kokoonpanopöytäruokaset mukaan - suunnitelman mukaan - erillisen ohjeen mukaan	
7	Säätöjen kojeisiin ja lähtösuunta: - vain viranomaisvaatimukset - erillisen ohjeen mukaan	
8	Vieras ohjauksen lähtösuunta: - ohjauksen lähtösuunta	
9	TN-C-S - järjestelmän varoituksilajit	
10	Kokoonpanopöytäruokaset mukaan	
11	Energianlähtösuunta: - lähtösuunta PE-laitteeseen - lähtösuunta PE-laitteeseen + varoituksilajit	

B	KOTELOINTI- JA ASENNUSTIEDOT	LEHTI
1	Kotelo ja koteloituus: - kotelon - kotelon - kotelon	
2	Asennustapa: - pinnalla - upotettu up. syv. max. - ulkokäyttö	
3	Käyttösuunta: - seinään - seinään ja tuenta laittaan - laittaan (vapaaehtoisesti)	
4	Asennus- ja tukirakenteet: - ei vaativat - sidekiskot n. 50mm alustasta	
5	Käyttösuuntaan yhteyttäminen ovi: - luoalla - kiskovalle - työkäyttöön - saranoitettuihin	
6	Ovien ja kansiin avautuminen ja leveys: - min. avautuminen 120° - max. oviavaruus - Pintakäyttö	
7	Asennustapa: - valmistajan normaalit - erillisen ohjeen mukaan	
8	Keskukseen maks. koko: - leveys 1200 mm - korkeus 2000 mm - syvyys 300 mm	
9	Ympäristön lämpötila: - normaalit - min. °C - max. °C	
10	Keskukseen kaapeliäntähti: - 1kpl / kojeentähti - 2kpl / kojeentähti	
11	Normaalit käyttöolosuhteet suorittajat: - sähköalan ammattihenkilöt - tehtävään opastettu henkilöt	

A	SÄHKÖTEKNILLISET TIEDOT	LEHTI
1	Nimellisjännite: U _e 400 V	
2	Nimellivirta: I _N 125 A	
3	Pakkaava tasotuskerroin: k ₁	
4	Jakelu- ja johtolinjat: - käyttömaadoitettu TN-S - nolla- ja suojajohdin yhdistetään TN-C-S - käyttömaadoitettu TN-C-S	
5	Teho: - lähtöteho S kVA - heipou (15 min mitti) P kW	
6	Dikotokäyttösuunta: - termian vastaus I _s 50 kA - dynaaminen vastaus I _{dyn} 100 kA	
7	Käyttösuunta ja johtolinjat: - LKPE - LU223/PE	
8	Käyttösuunta ja johtolinjat DC: - L+ - N - L- - PE	
9	Ohjauksen lähtösuunta (pääpiiri): - U _e V - I _N A - S kVA	
10	Apujännite 1: - U ₁ V - AC - DC	
11	Apujännite 2: - U ₂ V - AC - DC	

Lisätietoja	LEHTI
KS. KÄYTTÖOHJEKIRJASTEN VAATIMUKSET	

D	KALUSTUS- JA KAAPELOINTITIEDOT	LEHTI
1	Kalustustapa: - kaakelit - yksikkölohdot	1/5
2	Kalustuksen tyyppi: - kiinteä - ulosotettava - ulosvedettävä	
3	Merkitämpi: - merkkipöytä - hoitopöytä - led-lampot	
4	Laskutuslaitteiden toimittaja: - Hiaaja - keskusvalmistaja / urakoitsija	
5	Laskutuslaitteiden toimittaja: - Hiaaja	
6	Muiden laitteiden koko:	
7	Syöttö: - kaapeli - kiskosto	
8	Syöttö tulo: - aihaita - yhäältä - vasemmalta - oikealta	
9	Kaapeleiden lähtösuunta: - alas	
10	Pääpiirin kaapeleiden lähtösuunta: - ylös - kojeisiin - rivillä - rivillä, myös N ja PE - kojeisiin alkaen	
11	Ohjauksen lähtösuunta: - vasemmalta - oikealta	

C	HYVÄKSYTTÄMINEN JA MERKINNÄT	LEHTI
1	Kokoonpanopöytäruokaset hyväksyy: - suunnitelma - valvoja - sähkölaite	
2	Merkitämpi: - vain viranomaisvaatimukset - suunnitelman mukaan - erillisen ohjeen mukaan	
3	Keskukseen tunnuslausekset: - vain viranomaisvaatimukset - pääkaavion mukaan	
4	Käpien materiaali: - herrossuovi - farra	
5	Keskukseen kehitettävien tunnuslausekset: - valmistajan normaalit - vasaamalla oikealle - oikealla vasemmalle	
6	Kokoonpanopöytäruokaset mukaan - suunnitelman mukaan - erillisen ohjeen mukaan	
7	Säätöjen kojeisiin ja lähtösuunta: - vain viranomaisvaatimukset - erillisen ohjeen mukaan	
8	Vieras ohjauksen lähtösuunta: - ohjauksen lähtösuunta	
9	TN-C-S - järjestelmän varoituksilajit	
10	Kokoonpanopöytäruokaset mukaan	
11	Energianlähtösuunta: - lähtösuunta PE-laitteeseen - lähtösuunta PE-laitteeseen + varoituksilajit	

B	KOTELOINTI- JA ASENNUSTIEDOT	LEHTI
1	Kotelo ja koteloituus: - kotelon - kotelon - kotelon	
2	Asennustapa: - pinnalla - upotettu up. syv. max. - ulkokäyttö	
3	Käyttösuunta: - seinään - seinään ja tuenta laittaan - laittaan (vapaaehtoisesti)	
4	Asennus- ja tukirakenteet: - ei vaativat - sidekiskot n. 50mm alustasta	
5	Käyttösuuntaan yhteyttäminen ovi: - luoalla - kiskovalle - työkäyttöön - saranoitettuihin	
6	Ovien ja kansiin avautuminen ja leveys: - min. avautuminen 120° - max. oviavaruus - Pintakäyttö	
7	Asennustapa: - valmistajan normaalit - erillisen ohjeen mukaan	
8	Keskukseen maks. koko: - leveys 1200 mm - korkeus 2000 mm - syvyys 300 mm	
9	Ympäristön lämpötila: - normaalit - min. °C - max. °C	
10	Keskukseen kaapeliäntähti: - 1kpl / kojeentähti - 2kpl / kojeentähti	
11	Normaalit käyttöolosuhteet suorittajat: - sähköalan ammattihenkilöt - tehtävään opastettu henkilöt	

A	SÄHKÖTEKNILLISET TIEDOT	LEHTI
1	Nimellisjännite: U _e 400 V	
2	Nimellivirta: I _N 125 A	
3	Pakkaava tasotuskerroin: k ₁	
4	Jakelu- ja johtolinjat: - käyttömaadoitettu TN-S - nolla- ja suojajohdin yhdistetään TN-C-S - käyttömaadoitettu TN-C-S	
5	Teho: - lähtöteho S kVA - heipou (15 min mitti) P kW	
6	Dikotokäyttösuunta: - termian vastaus I _s 50 kA - dynaaminen vastaus I _{dyn} 100 kA	
7	Käyttösuunta ja johtolinjat: - LKPE - LU223/PE	
8	Käyttösuunta ja johtolinjat DC: - L+ - N - L- - PE	
9	Ohjauksen lähtösuunta (pääpiiri): - U _e V - I _N A - S kVA	
10	Apujännite 1: - U ₁ V - AC - DC	
11	Apujännite 2: - U ₂ V - AC - DC	

Lisätietoja	LEHTI
KS. KÄYTTÖOHJEKIRJASTEN VAATIMUKSET	

XP Aluminium busbar rated values 800 - 4000 A

Description	800 A	1000 A	1250 A	1600 A	2000 A	2500 A	3200 A	4000 A
Standards	BSEN 61439-6, EN 61439-6, IEC 61439-6							
Rated current	800 A	1000 A	1250 A	1600 A	2000 A	2500 A	3200 A	4000 A
This is the maximum current per pole. Single-phase tap-off units must be evenly distributed across the poles so as not to exceed the current rating in one pole or the neutral.								
Rated insulation voltage (Ui)	1000 Vac	1000 Vac	1000 Vac	1000 Vac	1000 Vac	1000 Vac	1000 Vac	1000 Vac
This is a.c. voltage that the trunking system is designed for and is the maximum 3-phase voltage that trunking system is designed to operate at in service.								
Rated frequency	50 Hz	50 Hz	50 Hz	50 Hz	50 Hz	50 Hz	50 Hz	50 Hz
Impulse withstand voltage	8 kV	8 kV	8 kV	8 kV	8 kV	8 kV	8 kV	8 kV
Phase resistance R20 [Ω /m]	0,0000857	0,000061	0,0000463	0,0000353	0,0000288	0,0000227	0,0000202	0,0000136
This is the resistance R20 (at 20°C) of the conductor of each phase pole and the neutral and is used in the calculation of fault current, earth-loop impedance and voltage drop.								
Phase resistance R [Ω /m]	0,000115	0,0000814	0,0000615	0,0000489	0,0000397	0,0000324	0,0000277	0,000019
This is the resistance R at full-load operating temperature (at an ambient air temperature of 35°C) of the conductor of each phase pole and the neutral and is used in the calculation of earth-loop impedance where required by wiring regulations.								
Phase reactance 50 Hz [Ω /m]	0,0000259	0,0000179	0,0000147	0,0000097	0,0000083	0,000005	0,0000041	0,0000034
This is the inductive reactance X of each phase pole and the neutral and is used in the calculation of fault current, volt-drop and circuit impedance.								
PE resistance (at 20°C) Internal Aluminium bar [Ω /m]	0,0000857	0,000061	0,0000463	0,0000353	0,0000288	0,0000227	0,0000202	0,0000136
PE resistance (at 20°C) Aluminium case [Ω /m]	0,0001458	0,0001452	0,0001447	0,0001442	0,0001437	0,0001430	0,0001424	0,0001418
The PE resistance and reactance are used in the calculation of the fault level to earth.								
Phase Conductor CSA (mm ²)	382	562	742	952	1192	1484	1904	2384
Neutral Conductor CSA (mm ²)	382	562	742	952	1192	1484	1904	2384
PE Conductor (internal bar) CSA (mm ²)	382	562	742	952	1192	1484	1904	2384
PE Conductor (case) CSA (mm ²)	3259	3482	3705	3962	4254	4729	5244	5843
Maximum short circuit current 3 phase R20 [Ω /m]	0,0000857	0,0000609	0,0000463	0,0000353	0,0000288	0,0000227	0,0000202	0,0000136
Short circuit reactance 3 phase X [Ω /m]	0,0000259	0,0000179	0,0000147	0,0000097	0,0000083	0,0000050	0,0000041	0,0000034
Maximum short circuit current phase to phase Rb20pHph [Ω /m]	0,0002050	0,0001640	0,0001260	0,0000949	0,0000789	0,0000559	0,0000412	0,0000330
Minimum short circuit current phase to phase Rbphph [Ω /m]	0,0002750	0,0002200	0,0001710	0,0001350	0,0001090	0,0000798	0,0000563	0,0000466
Short circuit reactance phase to phase Xbphph [Ω /m]	0,0000508	0,0000265	0,0000210	0,0000180	0,0000165	0,0000143	0,0000111	0,0000086
Maximum short circuit current phase to neutral Rb20pHn [Ω /m]	0,0002060	0,0001580	0,0001260	0,0000948	0,0000785	0,0000548	0,0000427	0,0000330
Minimum short circuit current phase to neutral Rbphn [Ω /m]	0,0002760	0,0002110	0,0001690	0,0001300	0,0001080	0,0000783	0,0000620	0,0000488
Short circuit reactance phase to neutral Xbphn [Ω /m]	0,0000698	0,0000548	0,0000415	0,0000308	0,0000242	0,0000177	0,0000135	0,0000103
Earth fault current phase to CPC (case) RbphPE [Ω /m]	0,0002230	0,0002030	0,0001900	0,0001750	0,0001580	0,0001360	0,0001130	0,0001050
Earth fault reactance phase to CPC (case) XbphPE [Ω /m]	0,0000964	0,0000910	0,0000802	0,0000738	0,0000683	0,0000634	0,0000578	0,0000541
These fault-loop values permit calculations of fault currents according to the method of impedances.								
Volt-drop [V/A/m]								
- Unity pf	0,000199186	0,000140989	0,000106521	0,000084697	0,000068762	0,000056118	0,000047978	0,000032909
- 0.9 pf	0,000198821	0,000140404	0,000106967	0,000083551	0,000068153	0,000054282	0,000046275	0,000032185
- 0.8 pf	0,000186265	0,000131393	0,000100494	0,000077838	0,000063636	0,000050091	0,000042643	0,000029861
- 0.7 pf	0,000171467	0,000120833	0,000092748	0,000071286	0,000058400	0,000045468	0,000038656	0,000027242
This figure allows an estimate to be made of the voltage drop along a run. This is the phase-to-phase voltage drop per ampere of load, along a 1m run without tap-offs. When loaded with tap-off units evenly distributed along the run the figures are multiplied by 0.55.								
Overload current protection								
Rated current of fuses or circuit breaker (A)	800	1000	1250	1600	2000	2500	3200	4000
Fault current protection (S/C)								
- 3 Phase 1-second short-time withstand current I _{sw} [kA]	30	55	70	75	100	100	100	100
- 3 Phase peak current withstand [kA]	63	121	154	165	220	220	220	220
- 1 Phase 1-second short-time withstand current I _{sw} Ph-N & Ph-E [kA]	18	33	42	45	60	60	60	60
- 1 Phase peak current withstand Ph-N & Ph-E [kA]	36	69	88	95	132	132	132	132
The short-time current and time together with the peak withstand current allow determination of circuit-breaker characteristics required for S/C protection.								
Weight of trunking [Kg/m]								
4-bar distribution (TP&N + case earth + joint)	17.6	20.3	22.6	27.5	31.0	35.9	45.1	52.5
Degree of protection to BSEN 60529	IP55	IP55	IP55	IP55	IP55	IP55	IP55	IP55
Mechanical Impact	IK08	IK08	IK08	IK08	IK08	IK08	IK08	IK08
Trunking Size W x D [mm]:								
a) trunking	175 x 140	175 x 170	175 x 200	175 x 235	175 x 275	175 x 340	175 x 410	175 x 490
b) overall including joint covers	226 x 173	226 x 203	226 x 233	226 x 268	226 x 308	226 x 373	226 x 443	226 x 523

APPENDIX 5: MCMKA 4X95/50 CABLE DATASHEET (NEXANS, 2016)

**Contact**

Installation & Industry Cables
Phone: 040 70 78 444
building-pc.se@nexans.com

MCMK / FKKJ / EKKJ 1 kV 4-conductor

MCMK 1 kV 4X95/50

Nexans ref.: 15284900198

Country ref.: 0602860

The cable may be used for fixed installation indoors and outdoors in air, ground and water.

Description

MCMK is a lead free PVC insulated, PVC sheathed cable with circular, solid or stranded copper conductors for cross-sections up to and including 35 mm². Other cross-sections have sector shaped, stranded copper conductors. The cable has a screen of annealed copper wires with opposite open helix of copper. MCMK is designed according to HD 603. The conductors have resistance and number of wires according to IEC 60228. The cores are identified by colours according to HD 308. The cable has an extruded filler of PVC. The sheath is marked type/manufacturer/year+month/metre marking. MCMK meets the requirements for flammability according to IEC 60332-1 (F2) for cross-sections up to 16 mm², other cross-sections meet the requirements for flammability according IEC 60332-3 category B (F4B). The cable is certified by SETI.

**Environmental declaration**

The external surface of the outer sheath is embossed with a text which specifies all components in the polymers and prepares the cable for future recycling.

Standards

MCMK is manufactured and tested according to valid power current regulations and HD 603 S1/3L. The cable can be loaded according to valid power current regulations

**Certification**

Certified by SETI.

Flammability class

MCMK meets the requirements for flammability according to IEC 60332-1 (F2) for cross-sections up to 16 mm², other cross-sections meet the requirements for flammability according IEC 60332-3 category B (F4B)

Standards

International HD 603 S1/3F

National SFS 4880

Quality system

Designed, manufactured and tested in accordance with ISO 9001.

Environmental management system

The activities at our plant in Grimsås are certified to ISO 14001.

							
Conductor flexibility Stranded class 2	Lead free Yes	Rated Voltage U ₀ /U (U _m) 0.6/1 kV	Minimum installation temperature -15 °C	Maximum operating temperature 70 °C	operation bending rad. 328 mm	static bending rad. 410 mm	Flame retardant IEC 60332-1
Generated 4/8/16 - http://www.nexans-fi.com							Page 1 / 2
All drawings, designs, specifications, plans and particulars of weights, size and dimensions contained in the technical or commercial documentation of Nexans is indicative only and shall not be binding on Nexans or be treated as constituting a representation on the part of Nexans.							

**Contact**

Installation & Industry Cables
 Phone: 040 70 78 444
 building-pc.se@nexans.com

MCMK / FKKJ / EKKJ 1 kV 4-conductor

MCMK 1 kV 4X95/50

Nexans ref.: 15284900198

Characteristics

Construction characteristics	
Conductor material	Copper
Conductor flexibility	Stranded class 2
Insulation	PVC
Outer sheath	PVC
Colour	Black
Lead free	Yes
Conductor shape	Sector-shaped
Dimensional characteristics	
Number of cores	4
Conductor cross-section	95 mm ²
Conductor diameter	1.5 mm
Average insulation thickness	1.6 mm
Screen section	50 mm ²
Average sheath thickness	2.2 mm
Nominal outer diameter	40.3 mm
Approximate weight	474.2 kg/100m
Electrical characteristics	
Max. DC resistance of the conductor at 20°C	0.193 Ohm/km
Resistance of the screen	0.39 Ohm/km
Nominal inductance	0.21 mH/km
Rated Voltage U ₀ /U (U _m)	0.6/1 kV
Usage characteristics	
Minimum installation temperature	-15 °C
Maximum operating temperature	70 °C
Short-circuit max. conductor temperature	150 °C
Laying operation bending radius	328 mm
Minimum static operating bending radius	410 mm
Length	500 m
Flame retardant	IEC 60332-1
Packaging	K16
Ambient static operating temperature, range	-40 .. 70 °C

Selling information

MCMK 4-conductor will be delivered in lengths of 500 m. The drum is marked with manufacturer, type of cable and length. The ends of the cable are sealed.

APPENDIX 6: EXAMPLE NETWORK WITH ABB EDESIGN DOC

